

ITEM NO.	DESCRIPTION	QTY.
1	SUB-FLASHING, CONE, 9"X9"X.020"/.032", 3003 AL, MILL	1
2	COUNTER FLASHING, CONDUIT, 1/2", 3/4", 1", EPDM RUBBER	2
3	FLASHING, CONE, 18"X18"X.032", 3003 AL, MILL	1

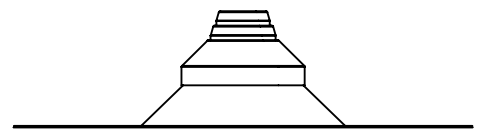

DETAIL B
SCALE 1 : 4

NOTES APPLY TO UPPER AND LOWER COUNTER FLASHINGS

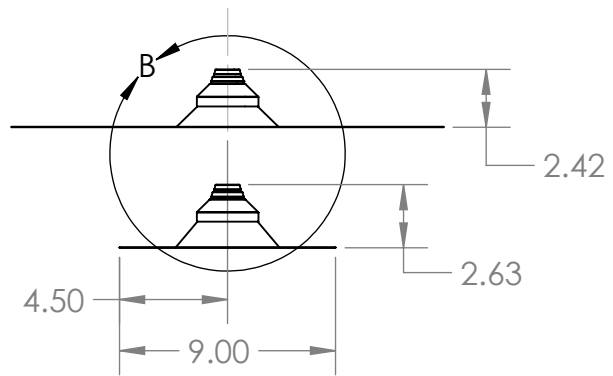
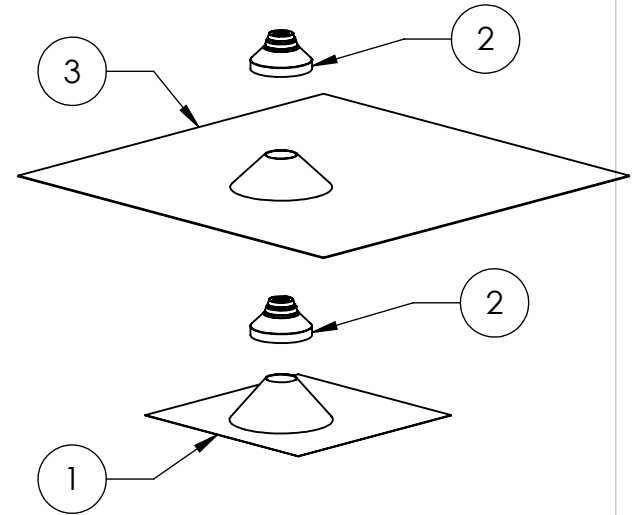
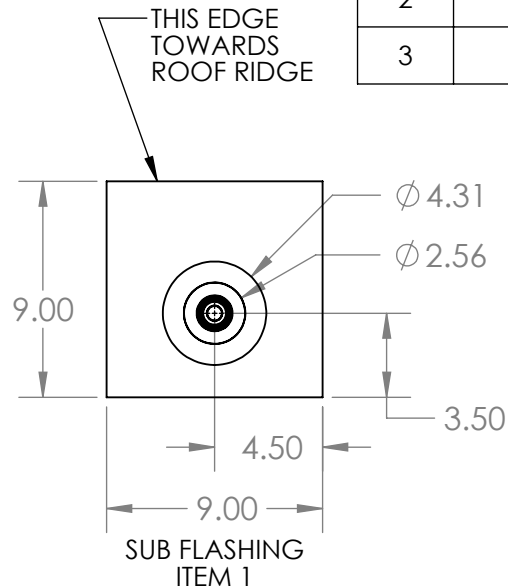
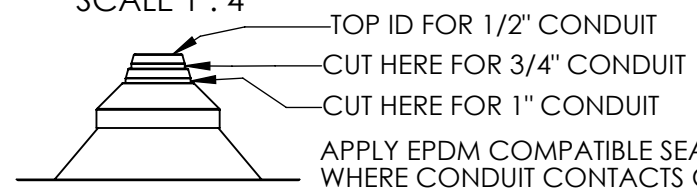

APPLY EPDM COMPATIBLE SEALANT WHERE CONDUIT CONTACTS COUNTER FLASHING

- NOTES:
1. AVAILABLE IN MILL FINISH, AND BRONZE ANODIZED FINISH.
 2. FLASHINGS MAY BE SPUN, OR PRESSED
 3. ITEM 1 MATERIAL THICKNESS: .020" SPUN, .032" PRESSED



TITLE:
QMCPT: CONDUIT PENETRATION FLASHING, TILE

UNLESS OTHERWISE SPECIFIED: DIMENSIONS ARE IN INCHES TOLERANCES: FRACTIONAL ± 1/8 TWO PLACE DECIMAL ±.19 THREE PLACE DECIMAL ±.094	SIZE A	DRAWN BY: AAP	REV 6
	SCALE: 1:8	DATE: 6/13/2019	WEIGHT: 1.32
		SHEET 1 OF 2	

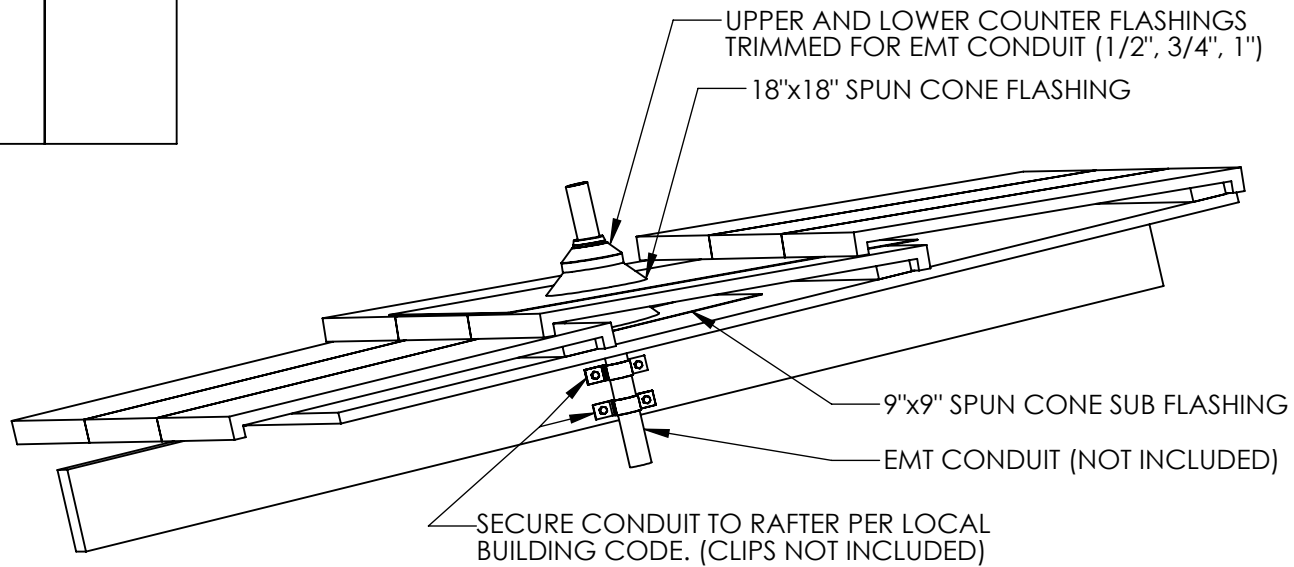
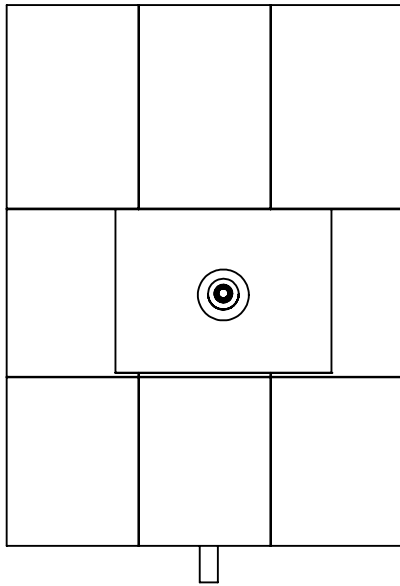

Quick Mount PV[®]

TITLE:
**QMCPT: CONDUIT PENETRATION
 FLASHING, TILE**

UNLESS OTHERWISE SPECIFIED: DIMENSIONS ARE IN INCHES TOLERANCES: FRACTIONAL ± 1/8 TWO PLACE DECIMAL ±.19 THREE PLACE DECIMAL ±.094	SIZE	DRAWN BY: AAP	REV
	A	DATE: 6/13/2019	6
SCALE: 1:8	WEIGHT: NA	SHEET 2 OF 2	

PROPRIETARY AND CONFIDENTIAL
 THE INFORMATION CONTAINED IN THIS DRAWING IS THE SOLE PROPERTY OF QUICK MOUNT PV. ANY REPRODUCTION IN PART OR AS A WHOLE WITHOUT THE WRITTEN PERMISSION OF QUICK MOUNT PV IS PROHIBITED. **COPYRIGHT © 2019 QUICK MOUNT PV**

DO NOT SCALE DRAWING

5

4

3

2

1