

SureSine

SINE WAVE INVERTER

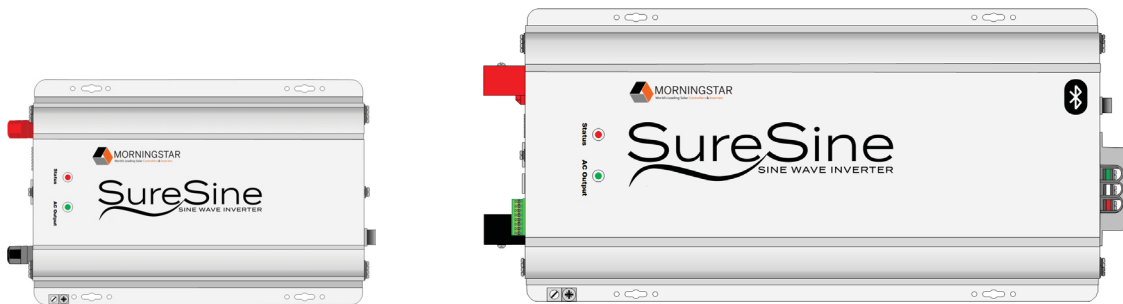

Installation and Operations Manual

**150 W, 300 W, & 700 W (12 V, 24 V, & 48 V) Models,
1,000 W & 1,250 W, (24 V & 48 V) Models,
2,500 W (48 V Only) Models
(120 V / 60 Hz, 230 V / 50 Hz,
127 V / 60 Hz, and 220 V / 60 Hz)**

November 2023 (Rev 3)

About MorningStar:

With well over 4 million products sold in over 100 countries since 1993—functioning in some of the most extreme environments and mission-critical applications in the world—Morningstar Corporation can truly claim to be “the leading supplier of solar controllers and inverters.” That success is why Morningstar has had staying power and stable management for over 27 years, along with the lowest employee turnover rate.

- Smarter digital design has been pioneered for solar components, for faster, more agile processing on-board. This allows for the maximum performance from the hardware.
- Advanced thermal engineering is used to eliminate cooling fans—the weak link in competitors’ products.
- Finally, internal electronics are laid out for performance and longevity instead of economics—designing for the long-term in order to achieve the industry’s lowest hardware failure rates.

For additional information about Morningstar Corporation, go to:

www.morningstarcorp.com

Disclaimer:

The specifications and descriptions contained in this document are verified to be as accurate as possible at the time of publication. However, because Morningstar Corporation’s products and their performance are constantly evolving, Morningstar reserves the right to make product or documentation modifications at any time, with or without notice. Due to the wide range of applications where this product can be used, details may vary by product version, geography, and site application.

To ensure that you have the most current version of this document, go to:

www.morningstarcorp.com/support.

To communicate any inaccuracies or omissions in this document, please fill out a contact form at:

www.morningstarcorp.com/support.

Reference document #: MS-003650. Rev 3

Contact Information:

Morningstar Corporation

8 Pheasant Run

Newtown, Pennsylvania 18940 USA

Email:	support@morningstarcorp.com
Website:	www.morningstarcorp.com
Service and Support:	www.morningstarcorp.com/support
Phone:	+1 215.321.4457

Copyright 2023:

This document and its contents are protected by trade secrets, patent, copyright, and other applicable laws. All rights are reserved. Unauthorized use is illegal.

SureSine™ is a trademark of Morningstar Corporation

ModBus™ and ModBus TCP/IP™ are trademarks of ModBus IDA. www.modbus-ida.org



© 2023 Morningstar Corporation. All rights reserved.

IMPORTANT SAFETY INSTRUCTIONS

SAVE THESE INSTRUCTIONS - This manual contains important safety, installation, and operating instructions for the Morningstar SureSine Inverter.

The SureSine produces voltages and currents capable of causing severe injury or death. Extreme caution must be taken when installing and using the SureSine.

The following symbols are used throughout this manual to indicate potentially dangerous conditions or important safety instructions.

	<p>WARNING: Indicates a potentially dangerous condition. Failure to observe this notice could result in severe personal injury or death.</p>
	<p>CAUTION: Indicates a critical procedure for safe and proper operation of the SureSine. Use extreme caution when performing this task. Failure to observe this notice could result in personal injury or equipment damage.</p>
	<p>NOTE: Indicates a procedure or function that is important to the safe and proper operation of the SureSine Inverter.</p>

GENERAL SAFETY INFORMATION

Throughout this manual, NEC guidance has been provided in order to meet general safety requirements and inform best installation practices. It is the installer's responsibility to ensure that the Installation complies with all local safety and code requirements.

- Read all of the instructions and cautions in the manual before starting the installation.
- Ensure that battery power has been disconnected BEFORE installing, servicing, or removing the SureSine Inverter.
- Do not allow water to enter the SureSine.
- Avoid wearing jewelry while installing this equipment.
- Do not smoke near the battery bank.
- Ensure power connections remain tight to avoid excessive heating from a loose connection.
- Recycle the battery when it is replaced.

WIRE AND CABLE SAFETY

Proper wire type and size is required for all installations. Use only UL-listed Class B or Class C wire rated for 300 volts and 75°C or higher. Use stranded wire for the battery circuit and solid or stranded wire for the AC and Ground circuits.

Copper wire is recommended instead of aluminum due to its ease of use, superior conductivity, strength and thermal expansion properties.



WARNING: SHOCK HAZARD

- **Installations must be performed by a qualified person trained in electrical safety procedures (minimum qualification).**
- All wiring must comply with local electric code requirements.
- For all 120 Vac models, the AC neutral output circuit is bonded to the inverter frame. The grounding electrode terminal of the chassis frame must be connected to a grounding electrode in accordance with local codes.
- Ensure all sources of **input** are disconnected before connecting **ANY** cabling.



WARNING: RISK OF FIRE

All over-current protection devices and wiring must be sized properly, in accordance with US National Electric Code (NEC) or the local regulations of the country of installation.



WARNING: FIRE HAZARD

A risk of fire may exist if a 120 Vac power source is wired incorrectly to 120/240 Vac panel containing multi-wire branch circuits.

MOUNTING, CLEARANCE, AND LOCATION SAFETY



WARNING: EXPLOSION/FIRE HAZARD

Do not install in a confined area where battery gases can accumulate. Battery gases can create an explosion or fire hazard if ignited by a spark. Ensure the enclosure is ventilated well enough to disperse any accumulated gases.

Do not install over an easily combustible surface, since the heat sink may get hot under certain operating conditions.



CAUTION: EQUIPMENT DAMAGE

- Do not mount in zero-clearance compartment. Overheating may result. Ensure adequate space around the components to ensure sufficient ventilation around the equipment.
- Locate the SureSine on a surface that is protected from direct sun, high temperatures, corrosive fumes, and water.
- Ensure the mounting surface is strong enough to support the weight of the inverter as well as any other devices that may be attached to it. It may be necessary to reinforce the surface with plywood to provide additional support for the equipment.

**CAUTION: HOT SURFACE/BURN HAZARD**

The SureSine inverter models 700 Watts to 2,500 W can become very hot. Install the SureSine so that it cannot be accidentally touched.

BATTERY SAFETY INFORMATION

**WARNING: SHOCK HAZARD**

- Servicing of batteries should be performed, or supervised, by personnel knowledgeable about batteries, and the proper safety precautions.
- Have someone nearby to assist in case of an accident.
- Carefully read the battery manufacturer's instructions before installing / connecting to, or removing batteries from the SureSine Inverter.
- A battery can present a risk of electrical shock or burn from large amounts of short-circuit current, fire, or explosion from vented gases. Observe proper precautions.
- Remove watches, rings, jewelry and other metal objects before working with batteries.
- Use tools with insulated handles and avoid placing tools or metal objects on top of batteries.
- Disconnect charging source prior to connecting or disconnecting battery terminals.
- Determine if battery is inadvertently grounded. If so, remove the source of contact with ground. Contact with any part of a grounded battery can result in electrical shock. The likelihood of such a shock can be reduced if battery grounds are removed during installation and maintenance (applicable to equipment and remote battery supplies not having a grounded supply circuit).

**WARNING: RISK OF EXPLOSION**

- Explosive battery gases can be present during charging. Be certain there is enough ventilation to release the gases.
- Proper disposal of batteries is required. Do not dispose of batteries in fire. Refer to local regulations or codes for requirements. Recycle the battery when it is replaced.
- Never smoke in the battery area.

**WARNING: CORROSION HAZARD/TOXIC FUMES**

- Do not open or mutilate batteries. Released electrolyte is harmful to skin and may be toxic if inhaled.
- Be very careful when working with large lead-acid batteries. Wear eye protection and have fresh water available in case there is contact with the battery acid.
- Wear rubber gloves and boots.
- If battery acid comes into contact with the skin, wash with soap and water. If the acid contacts the eye, flood with fresh water and get medical attention.
- Recycle the battery when it is replaced.

BATTERY SAFETY INFORMATION

(Continued)



CAUTION: EQUIPMENT DAMAGE

- Ensure the battery voltage matches the DC voltage requirements of the model of SureSine inverter to be installed.
- Ensure the battery bank consists of batteries of the same type, make and age.
- Ensure the battery electrolyte level is correct before starting charging. **Do not attempt to charge a frozen battery.**
- Ensure that the charging equipment implemented in the system meets the charging requirements for the battery bank and varied charging.
- The SureSine Low Voltage Disconnect (LVD) and Low Voltage Reconnect (LVR) presets are generally designed for lead acid batteries. Use custom LVD and LVR settings required for the type of battery in the system and minimum desired state of charge (SOC). Note that some battery types may not be compatible.

CERTIFICATIONS:

North American Certifications:

- Complies with UL 1741 and CSA-C22.2 No. 107.1
- Complies with FCC Article 15, Class B
- Complies with ICES-003 Issue 4, Feb 2004 (Class B)
- Complies with UL 458:2015 Ed.6+R:11 Jan2021

European LVD Directive:

- IEC/EN 62109-1:2010 Safety of Power Converters in PV Systems - Part 1: General Requirements
- IEC/EN 62109-2: 2011 Safety of power converters for use in photovoltaic power systems - Part 2: Particular requirements for inverters

European EMC Directive:

- IEC/EN 61000-6-1, IEC/EN 61000-6-2, IEC/EN 61000-6-3, IEC/EN 61000-6-4,
- IEC/EN 55032, IEC/EN55011

Table of Contents

1.0	Introduction	1
1.1	Features.....	1
1.2	Components of the 150 W & 300 W Models.....	2
1.3	Components of the 700 W Models.....	3
1.4	Components of the 1,000 W to 2,500 W Models.....	4
1.5	Dimensions of the 150 W & 300 W Models.....	5
1.6	Dimensions of the 700 W to 2,500 W Models.....	6
2.0	Installation	7
2.1	Required Tools.....	7
2.2	Additional Hardware Requirements.....	7
2.3	Mounting.....	8
2.3.1	Safety Considerations for Mounting.....	9
2.3.2	Mounting Procedure.....	10
2.4	Adjusting Settings.....	11
2.4.1	DIP Switch Location.....	11
2.4.2	DIP Switch Configuration Options.....	12
2.5	Pluggable Terminal Block Installation for Remote Switch or Communications Wiring.....	13
2.6	Remote Switch Installation (Optional).....	14
2.7	Auxiliary Power (Optional).....	15
2.8	Inverter Wiring.....	16
2.8.1	Terminal Torque Requirements.....	16
2.8.2	Over-current Protection Requirements.....	17
2.8.3	DC and AC Conductor Sizing Requirements.....	18
2.8.4	Grounding and Bonding Requirements.....	20
2.8.5	Grounding Connections.....	23
2.8.6	DC Connections.....	25
2.8.7	AC Connections.....	29
2.8.8	AC Wiring.....	30
2.9	Check Wiring and Power Up.....	32
3.0	Operation	32
3.1	LED Indications.....	32
3.2	Ethernet Jack LEDs.....	33
3.3	AC Output Mode Switch Operation.....	33
3.4	Protections.....	34
3.4.1	Low Voltage Disconnect (LVD).....	34
3.4.2	High Voltage Disconnect (HVD).....	34
3.4.3	High Temperature Disconnect (HTD).....	34
3.4.4	Over Current and Short Circuit Protection (Critical Fault).....	35
3.4.5	Reverse Polarity Protection.....	35
4.0	Communication Options	36
4.1	Ethernet Security.....	37
4.2	Bluetooth.....	38
4.2.1	To Connect the SureSine using Bluetooth.....	38
4.2.2	SureSine Mobile Utility App.....	39
4.3	Ethernet (for ModBus TCP/IP™).....	40
4.3.1	To Connect to a Local Area Network or to the Internet.....	41
4.4	EIA-485 Device Communication.....	42
4.4.1	To Connect the SureSine Inverter to an EIA-485 Device.....	42
4.5	USB Port.....	44

4.6	MS-CAN (Future Feature)	45
4.6.1	To Connect the SureSine to another Morningstar Device	45
4.6.2	To Connect the SureSine to a Morningstar Network	46
5.0	Firmware Update Procedure	47
6.0	Inspection and Maintenance	47
6.1	General Care	47
6.2	Inspection Schedule	47
6.2.1	Two (2) Weeks After Installation	47
6.2.2	Three (3) Months After Installation	47
6.2.3	Annual Inspection	48
6.3	Fuse Replacement	48
7.0	Specifications	50
7.1	SureSine Model Numbers	50
7.2	Technical Specifications	52
Appendix A:	DC Battery Wire Sizing	56
Appendix B:	DC Voltage Drop Tables	59
B.1	Voltage Drop Chart for 75°C or 90°C Stranded Copper Wire (Feet), 12 Volt System	59
B.2	Voltage Drop Chart for 75°C or 90°C Stranded Copper Wire (Meters), 12 Volt System	60
Appendix C:	Warranty	61
C.1	Claim Procedure	61
C.2	Warranty Exclusions And Limitations	61
Appendix D:	Revision History	63

List of Figures

Figure 1: SureSine Inverters Series	1
Figure 2: SureSine Inverter Features (150 W & 300 W Models)	2
Figure 3: SureSine Inverter Features (700 W Models)	3
Figure 4: SureSine Inverter Features (1,000 W to 2,500 W Models)	4
Figure 5: Dimensions - 150 W to 300 W Models	5
Figure 6: Dimensions - 700 W to 2,500 W Models	6
Figure 7: Mounting Orientation	8
Figure 8: Mounting Holes.....	8
Figure 9: Minimum Clearance and Ventilation Requirements	9
Figure 10: DIP Switches.....	11
Figure 11: DIP Switch Configurations	11
Figure 12: Pluggable Terminal Block (4-pin and 8-pin)	13
Figure 13: Terminal Block Installation	13
Figure 14: Remote Switch Wiring for 150 W to 300 W Models	14
Figure 15: Remote Switch Wiring for 700 W to 2,500 W Models	14
Figure 16: Auxiliary Power Terminals on 700 W to 2,500 W Models.....	15
Figure 17: Internal Grounded Neutral vs. External Grounded Neutral (Internal Neutral Ground Bond removed)	21
Figure 18: Neutral-Ground Jumper Wire	22
Figure 19: 150 to 300 W Internal Neutral-Ground Jumper	22
Figure 20: 700 to 2,500 W Internal Neutral-Ground Jumper	23
Figure 21: DC Connections on 150 W & 300 W Models with Negative Grounding	27
Figure 22: DC Connections on 150 W & 300 W Models with Positive Grounding	27
Figure 23: DC Connections on 700 W to 2,500 W Models with Negative Grounding	28
Figure 24: DC Connections on 700 W to 2,500 W Models with Positive Grounding.....	28
Figure 25: AC Connections on 150 W, 300 W, & 700 W Models (with Factory Wiring)	29
Figure 26: AC Wiring for 150 W or 300 W Models	31
Figure 27: AC Wiring for 700 W, 1,000 W, 1,250 W or 2,500 W Models	31
Figure 28: AC Output Mode Operation and Bluetooth Activation	33
Figure 29: Communication Port Locations (150 W & 300 W Models).....	36
Figure 30: Communication Port Locations (700 W to 2,500 W Models)	37
Figure 31: Communication using Bluetooth.....	38
Figure 32: SureSine Utility Mobile App (Main Dashboard).....	39
Figure 33: Communication using Ethernet.....	41
Figure 34: EIA-485/RS-232 Communications Adapter (RSC-1)	42
Figure 35: Connecting to an EIA-485 Device.....	42
Figure 36: Auxiliary Power Connections (700 W, 1,000 W, 1,250 W or 2,500 W Models ONLY) .	43
Figure 37: USB Port Locations.....	44
Figure 38: Communication Using MS-CAN.....	45

Figure 39: Communication Using MS-CAN with Multiple Devices	46
Figure 40: SureSine Mobile Utility App - Firmware Update Icon	47
Figure 41: Replacing the Fuses	49
Figure 42: SureSine Product Key	50

List of Tables

Table 1: DIP Switch Configuration	12
Table 2: Low Voltage Disconnect Settings (DIP 4 & 5)	12
Table 3: Terminal Torque Requirements	16
Table 4: DC Battery Circuit Breaker/Fuse Size.....	17
Table 5: AC Circuit Breaker/Fuse Size	18
Table 6: Minimum Battery Cable Size - 75°C rated Copper.....	19
Table 7: Minimum AC Output Wire Size - 75°C rated Copper.....	19
Table 8: Minimum Wire Sizes for Copper Ground Cable	24
Table 9: LED Indications	32
Table 10: Ethernet Jack LED Indications	33
Table 11: SureSine Model Numbers.....	50
Table 12: Specifications for the SureSine 150 and SureSine 300	52
Table 13: Specifications for the SureSine 700 and SureSine 1000	53
Table 14: Specifications for the SureSine 1250 and SureSine 2500	54
Table 15: Common Specifications for all Models	55
Table 16: Low Voltage Disconnect Settings	55
Table 17: Minimum Battery Wire Sizes - 75°C Rated Stranded Copper.....	56
Table 18: Minimum Battery Wire Sizes - 90°C Rated Stranded Copper.....	57
Table 19: Celsius-to-Fahrenheit Conversions	58
Table 20: Maximum 1-way Distance (Feet), 2% Voltage Drop Chart for 75°C or 90°C Stranded Copper Wire, 12-Volt System	59
Table 21: Maximum 1-way Distance (Meters), 2% Voltage Drop Chart for 75°C or 90°C Stranded Copper Wire, 12-Volt System	60

1.0 INTRODUCTION

The SureSine Inverter is a pure sine wave inverter for industrial and residential DC-to-AC applications which require high quality power. The SureSine can be used as a standalone system or as an accessory to larger systems that may include charging sources and energy storage systems.

1.1 Features

SureSine features include:

- Pure sine wave conversion produces a highly efficient AC grid-quality power.
- DC power to AC power conversion to the following output voltages:
 - 120-volt/60 Hz.
 - 127-volt/60 Hz.
 - 220-volt/60 Hz.
 - 230-volt/50 Hz
- Supports 12-volt, 24-volt, or 48-volt DC systems (dependent on model purchased).
- Extensive electronic protections ensure protection against faults and user mistakes such as short circuits, overloads, high temperatures, and low voltage disconnects. Recovery from most faults is automatic.
- Two LEDs provide important information to the user regarding battery status and AC output.
- Remote ON/OFF capability.
- Eight DIP switches provide easy adjustment of several system parameters.
- Multiple communication options.
 - Mobile devices can connect through Bluetooth
 - Other network devices can connect through Ethernet and/or EIA-485
 - FUTURE FEATURE: The SureSine Inverter can pair with other Morningstar products that feature MS-CAN Communication for control, adjustments, and monitoring performance

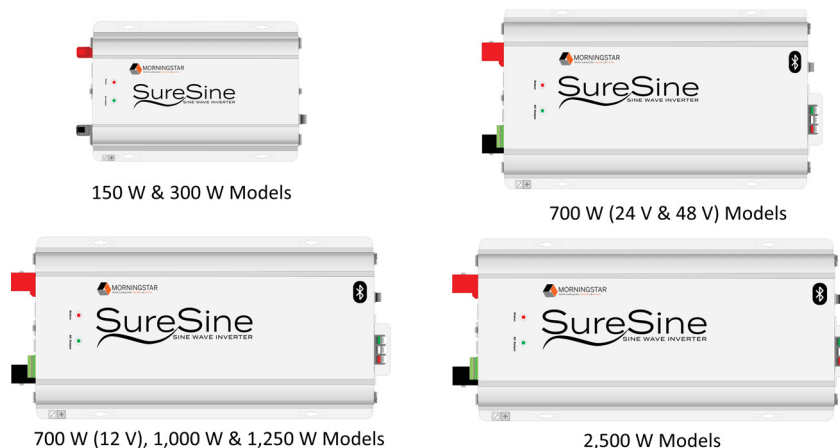

Figure 1: SureSine Inverters Series

1.2 Components of the 150 W & 300 W Models

Figure 2 shows the components included with the 150 and 300 W models.

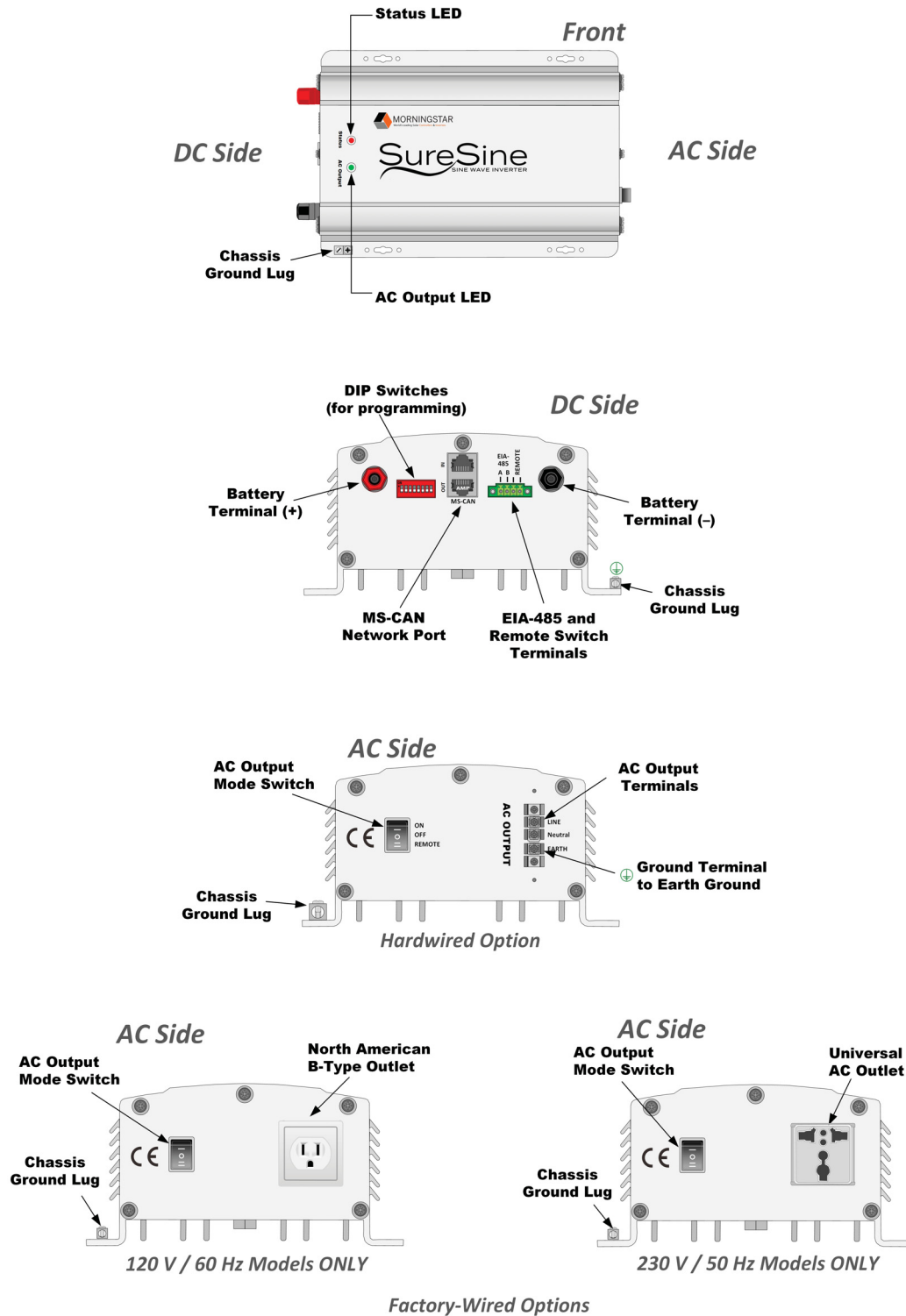

Figure 2: SureSine Inverter Features (150 W & 300 W Models)

1.3 Components of the 700 W Models

Figure 3 shows the components included with the 700 W models.

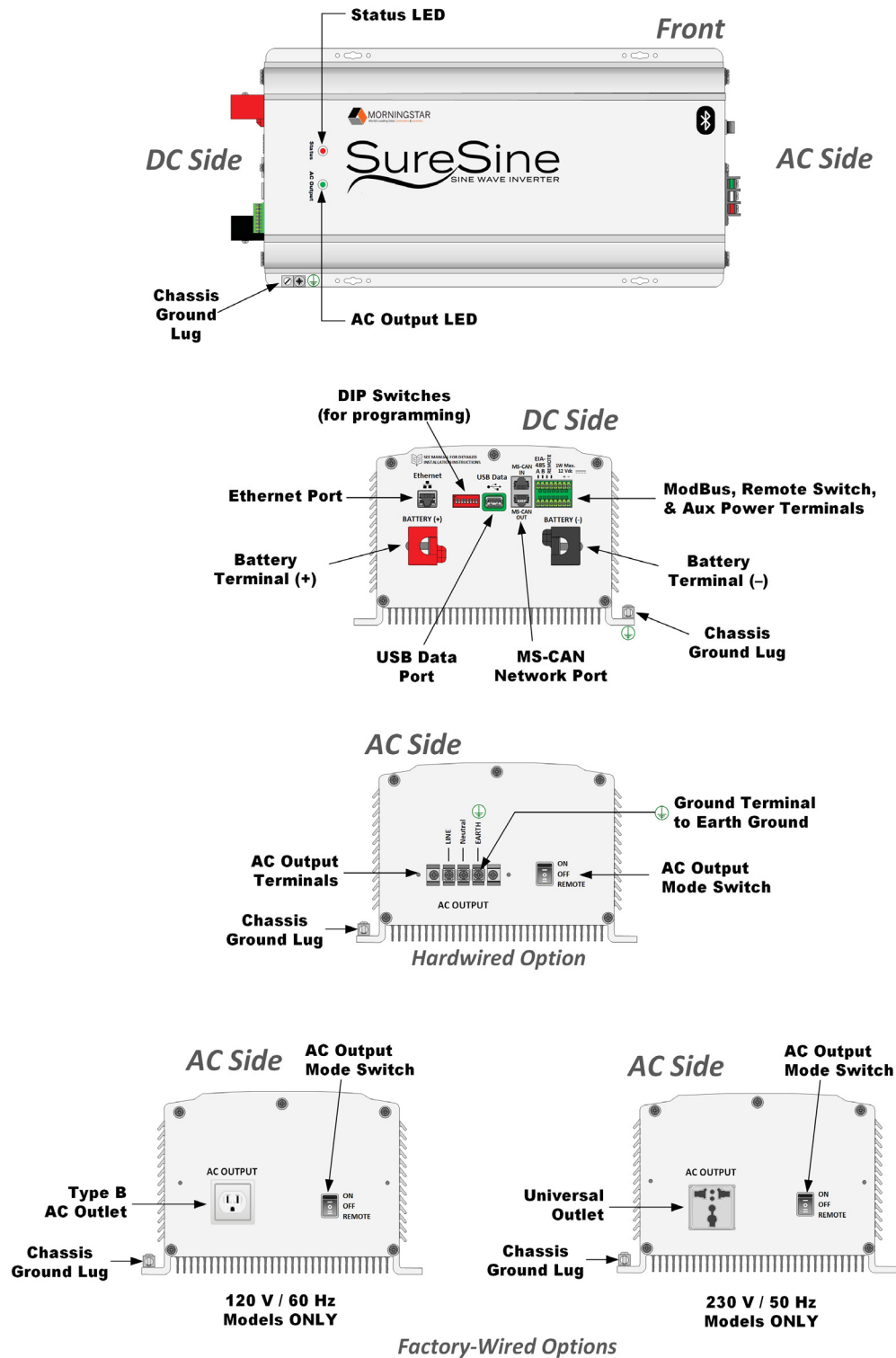

Figure 3: SureSine Inverter Features (700 W Models)

1.4 Components of the 1,000 W to 2,500 W Models

Figure 4 shows the components included with the 1,000 W to 2,500 W models.

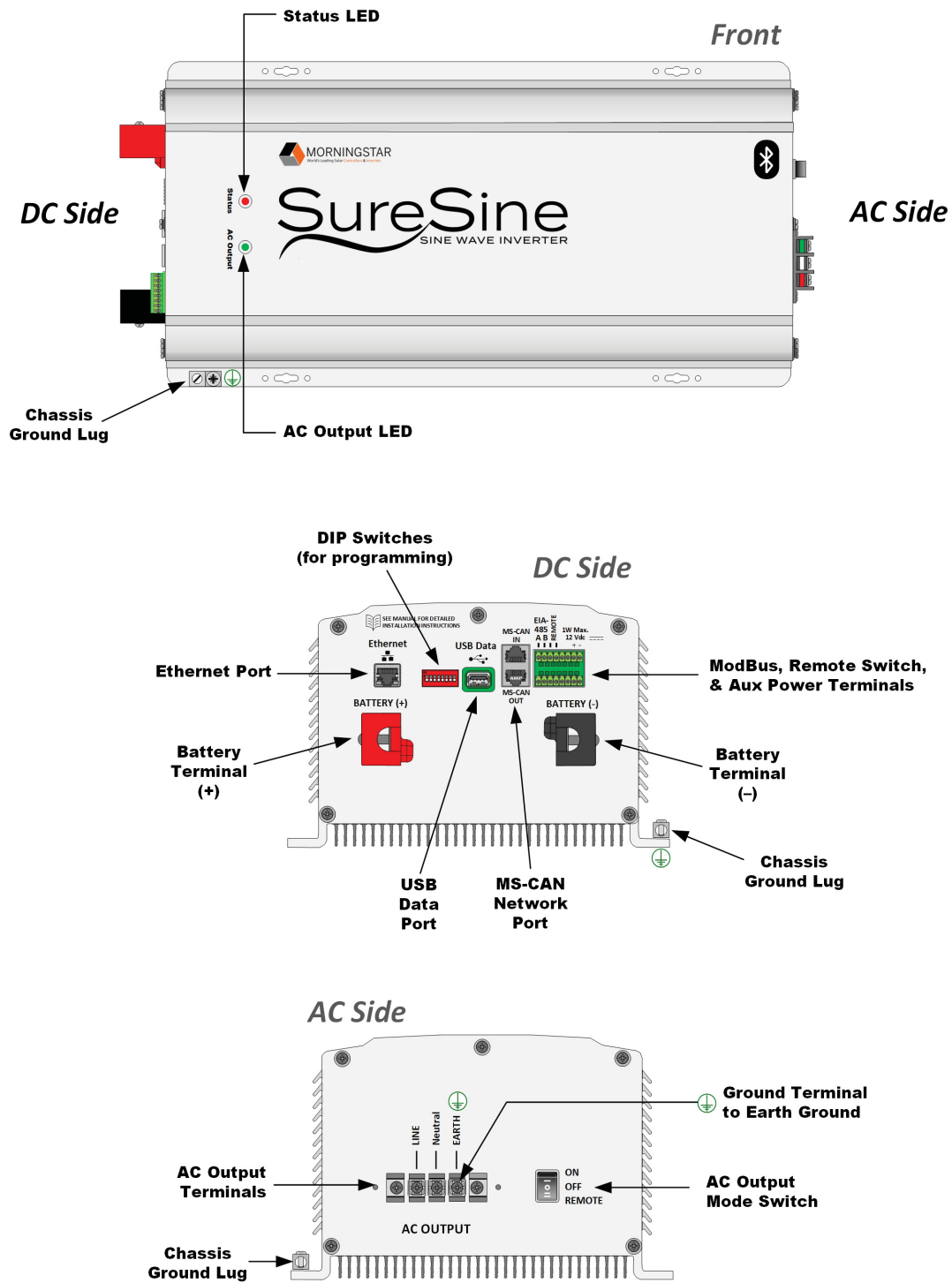

Figure 4: SureSine Inverter Features (1,000 W to 2,500 W Models)

1.5 Dimensions of the 150 W & 300 W Models

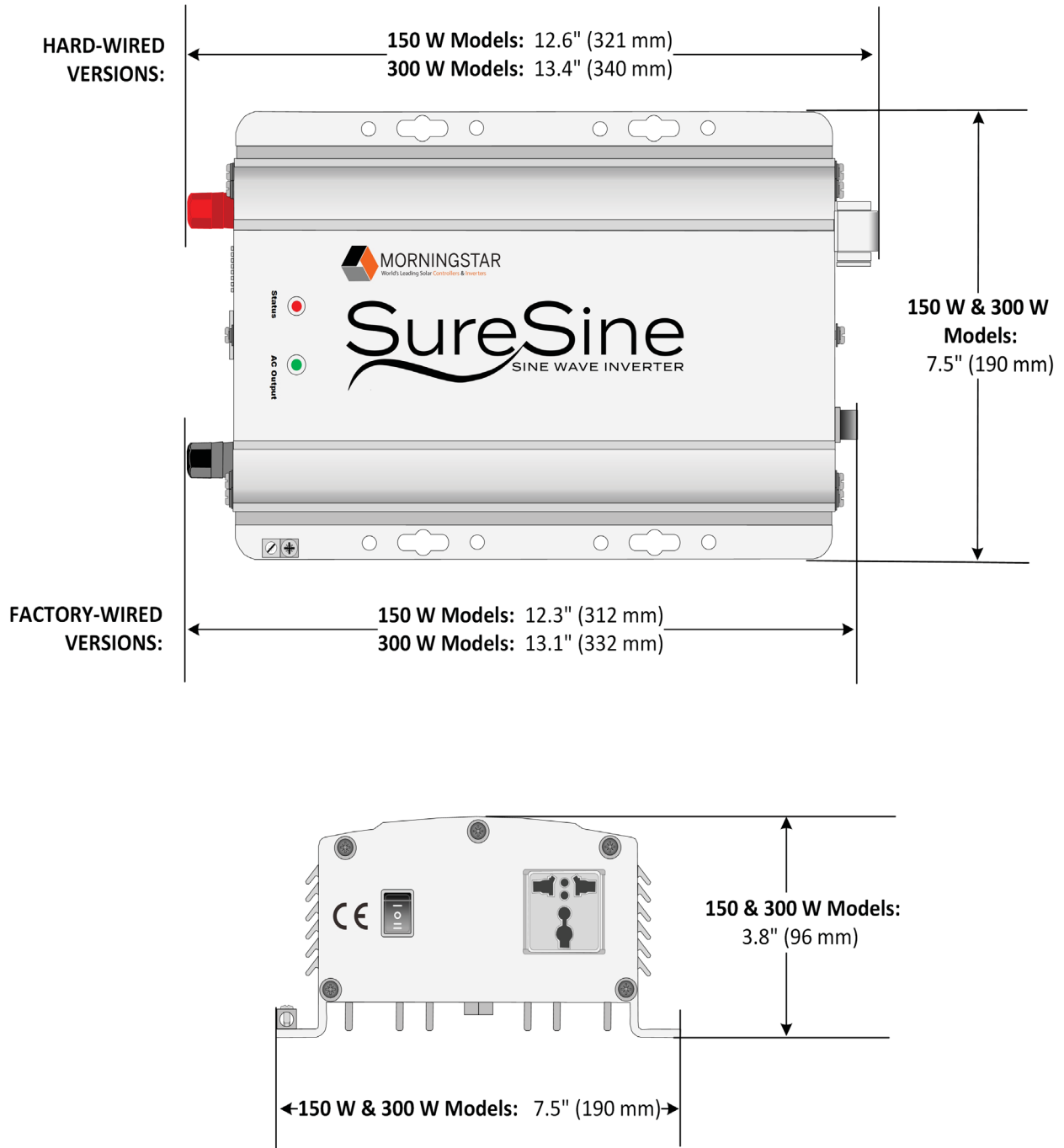

Figure 5: Dimensions - 150 W to 300 W Models

1.6 Dimensions of the 700 W to 2,500 W Models

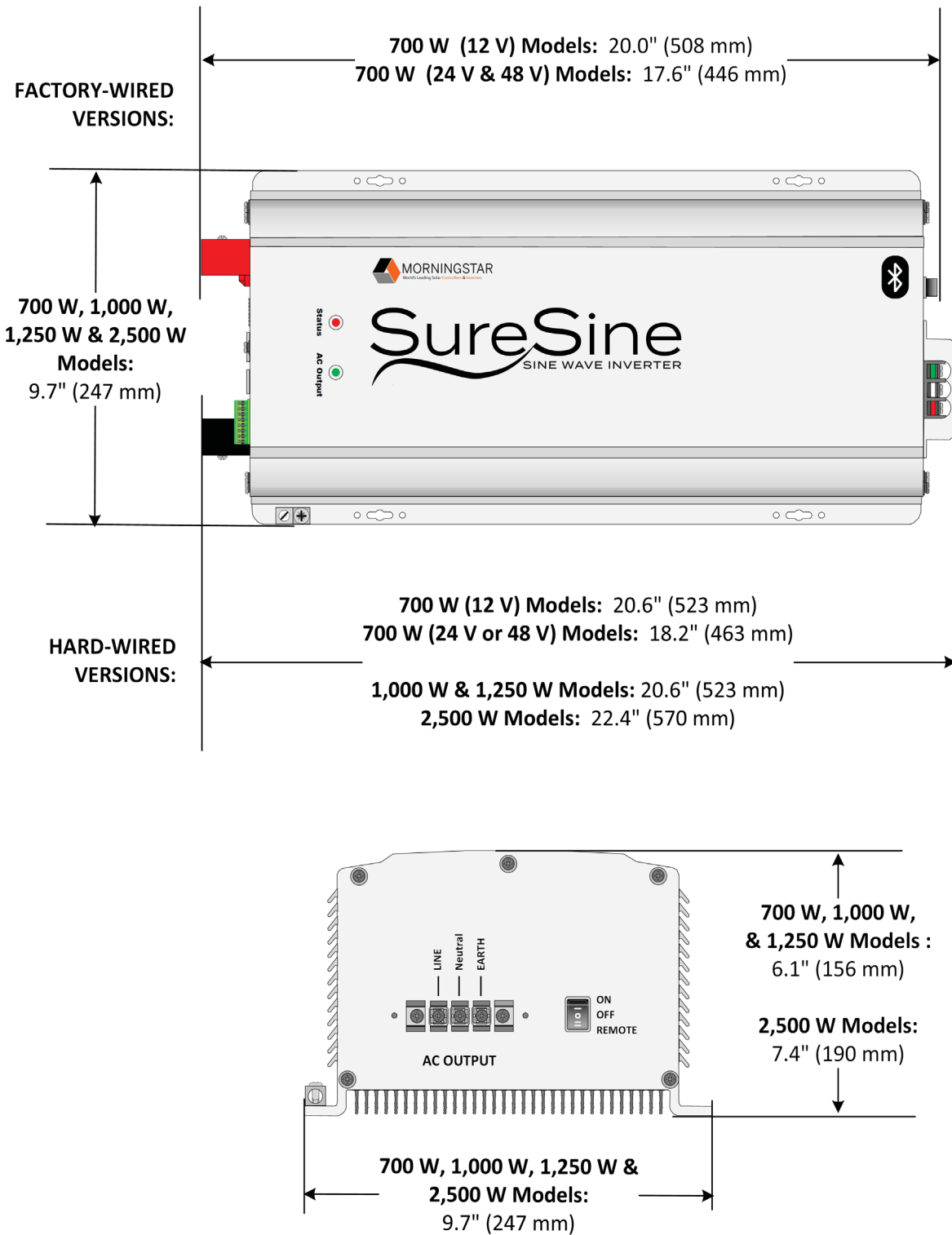

Figure 6: Dimensions - 700 W to 2,500 W Models



2.0 INSTALLATION

Included in the box:

- Mounting Screws (#10 x4)
- CAN Terminal resistor
- Terminal block connector (for ModBus™, Remote Switch, Auxiliary Power)



#10 Mounting Screws (x4)



Terminal Resistor



4-Pin Pluggable Terminal Block Connector (150 W & 300 W Models)



8-Pin Pluggable (x2) Terminal Block Connector (700 W to 2,500 W Models)

2.1 Required Tools



WARNING: SHOCK HAZARD

This product can produce hazardous voltage. Use insulated tools while working with this equipment.

The minimum required tools include the following. Additional tools may be required depending on the site application.

- Wire cutters/strippers
- Drill and 1/8" (3 mm) drill bit
- #2 Phillips and 3/16 (5 mm) & 1/8" (3.8 mm) Flat-head screwdrivers
- Multimeter
- Crimping Tool
- Wrench

2.2 Additional Hardware Requirements

Depending on the type of installation, additional hardware may be required. This hardware is NOT provided with the SureSine Inverter. These types of components include, but are not limited to:

- Battery or battery bank
 - Ensure the battery voltage matches the DC voltage requirements of the model of SureSine inverter to be installed.
 - Ensure the battery bank is comprised of batteries of the same type, make, and age.
- All DC and ground cables
- AC wiring for hardwired (HW) models only
- Sub panels, circuit breakers, fuses, Ground Fault Disconnects etc.
- Primary Earth Ground connection (e.g., ground rod)
- Remote Switch (Optional)

Consult the system design diagrams to determine the exact requirements for the installation.

2.3 Mounting

The SureSine may be mounted horizontally on a flat surface (like a table) or vertically (on a wall). If mounted vertically (on a wall), the inverter can be mounted either portrait style or landscape style. Ensure that there is enough space inside the enclosure for the wiring and ventilation. For optimal ventilation and cooling, mount in portrait style orientation.

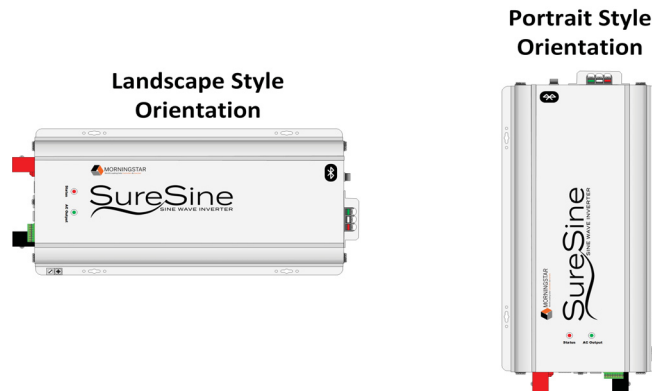

Figure 7: Mounting Orientation

Four Keyhole slots are provided to secure the inverter to the mounting surface.

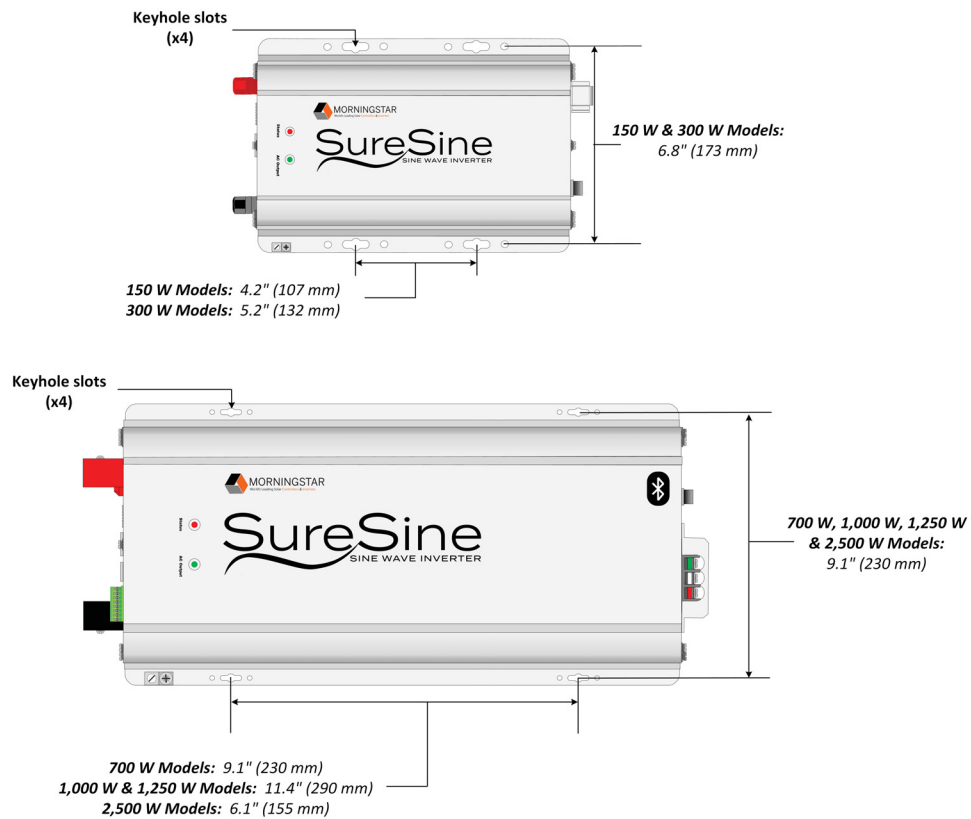

Figure 8: Mounting Holes



2.3.1 Safety Considerations for Mounting

	<p>WARNING: EXPLOSION/FIRE HAZARD</p>
	<p>Do not install in a confined area where battery gases can accumulate. Battery gases can create an explosion or fire hazard if ignited by a spark. Ensure the enclosure is ventilated well enough to disperse any accumulated gases.</p> <p>Do not install over an easily combustible surface, since the heat sink may get hot under certain operating conditions.</p>
	<p>CAUTION: EQUIPMENT DAMAGE</p>
	<ul style="list-style-type: none"> Do not mount in a compartment with inadequate clearance. Overheating may result and cause derated output power or shut off, and may reduce the life expectancy. Locate the SureSine on a surface that is protected from direct sun, high temperatures, corrosive fumes, and water. Ensure the mounting surface is strong enough to support the weight of the inverter as well as any other devices that may be attached to it. It may be necessary to reinforce the surface with plywood to provide additional support for the equipment.
	<p>CAUTION: HOT SURFACE/BURN HAZARD</p>
	<p>The SureSine inverter models 700 W to 2,500 W can become very hot. Install the SureSine so that it cannot be accidentally touched.</p>

For optimal ventilation and cooling, mount in the portrait style orientation.

Allow a minimum of 6" (152.4 mm) of space around the ends and 1" (25.4 mm) of space around the long edges of the SureSine for air flow.

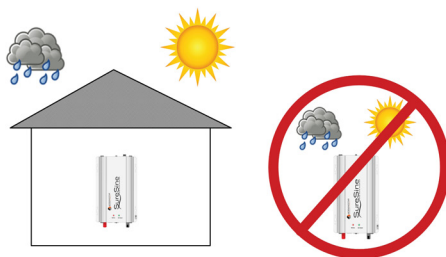

Protect from direct sun, high temperatures, corrosive fumes, dust, and water.



CAUTION: HOT SURFACE!
Place in a location to avoid direct contact.

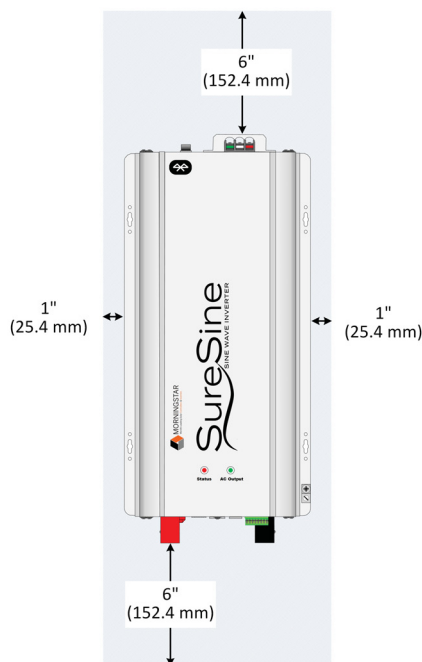

Figure 9: Minimum Clearance and Ventilation Requirements

2.3.2 Mounting Procedure

To secure the inverter to the mounting surface:

1. Place the SureSine on the surface where it will be mounted and determine where the wires will enter/exit.
 - Be sure there is sufficient bending room for the wires and other auxiliary connections, as required by local code.
 - Verify that the mounting screws will not penetrate wires or other objects located on the opposite side of the surface.
 - Ensure the surface is strong enough to support the weight of the inverter and anything else mounted on it. It may require additional support, such as a sheet of plywood.
2. With a pencil or pen, mark the mounting hole locations.
3. With a drill and 1/8" (3 mm) bit, drill pilot holes for each of the four mounting screw locations marked on the mounting surface.
4. Place the SureSine onto the surface and align the mounting feet holes with the four pilot holes. Use the #10 screws (included) to secure the SureSine to the surface.

2.4 Adjusting Settings

The SureSine has eight (8) DIP Switches that allow for adjusting specific operational parameters for the inverter. Each switch has an ON/OFF position. See Section 2.4.2 on page 12 for details on specific settings.



IMPORTANT:

Check that the DIP Switches are properly configured for the designed installation prior to installing the inverter.

2.4.1 DIP Switch Location

The DIP switches are located on the DC side of all models.

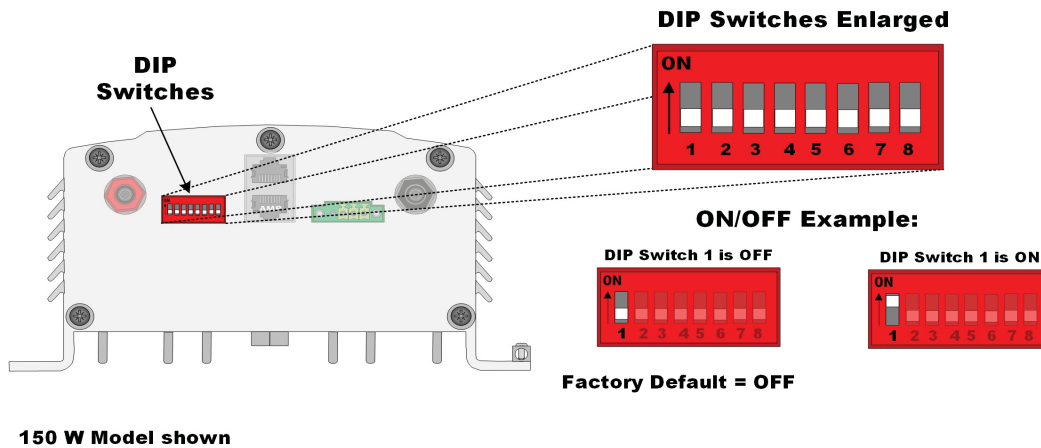

Figure 10: DIP Switches











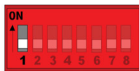



<p>DIP 1: OPERATIONAL CONTROL</p>   <p>DIP 1 OFF = Remote Switch Control DIP 1 ON = Remote Digital Control</p>	<p>DIP 4: LOW VOLTAGE DISCONNECT (LVD)</p>   <p>DIP 4 OFF = Custom DIP 4 ON = Presets</p>	<p>DIP 6: STANDBY MODE</p>   <p>DIP 6 OFF = AC Output Always ON DIP 6 ON = AC Output OFF < 8 W</p>
<p>DIP 2: ALARM SOUND</p>   <p>DIP 2 OFF = Alarm is Disabled DIP 2 ON = Alarm is Enabled</p>	<p>DIP 5: LOW VOLTAGE DISCONNECT (LVD) PRESETS</p>   <p>• For 12 Vdc Systems: DIP 5 OFF = 10.5 V DIP 5 ON = 11.5 V</p> <p>• For 24 Vdc Systems: DIP 5 OFF = 21.0 V DIP 5 ON = 23.0 V</p> <p>• For 48 Vdc Systems: DIP 5 OFF = 42.0 V DIP 5 ON = 46.0 V</p>	<p>DIP 7: 150 W & 300 W: NOT USED 700 W to 2,500 W:</p>   <p>DIP 7 OFF = Ethernet Write Disabled DIP 7 ON = Ethernet Write is Enabled</p>
<p>DIP 3: NOT USED (DEFAULT IS OFF)</p>  <p>ON Position is Disabled</p>	<p>DIP 8: BLUETOOTH COMMUNICATIONS</p>   <p>DIP 8 OFF = Bluetooth Disabled DIP 8 ON = Bluetooth Enabled</p> <p>DIP Switch 8 must be set before connecting DC power. If changed during operation, a power cycle is required.</p>	

Figure 11: DIP Switch Configurations

2.4.2 DIP Switch Configuration Options

DIP Switches control the operational functions of the inverter as follows.
The default position for these switches is OFF.

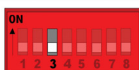
Table 1: DIP Switch Configuration

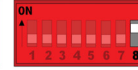
DIP Switch	Function	Status	Control Content
1	Operational Control (with AC Switch Down (Remote))	OFF	AC Output is controlled by the Remote ON/OFF Switch
		ON	AC Output is controlled by the communication command (digital command).
2	Alarm Sounds	OFF	Alarm OFF
		ON	Alarm ON
3	Not Used	OFF	Not Used - Default is OFF
		ON	Not Used - Default is OFF
4	Low Voltage Disconnect	OFF	CUSTOM. LVD is set to the factory-default values, but can be modified through RS485 communication port or Bluetooth App. See the factory-default settings in Table 2 for default values.
		ON	PRESETS. LVD is set with the #5 DIP Switch values and cannot be modified. See the Preset settings in Table 2 for Preset values.
5	Low Voltage Disconnect PRESETS (i.e., Default) For 12 V (24 V or 48 V) Systems	OFF	<ul style="list-style-type: none"> Low Voltage Disconnect (LVD) = 10.5 V (21 V or 42 V) Low Voltage Reconnect (LVR) = 11.6 V (23.2 V or 46.4 V) LVD Alarm = 10.8 V, (21.6 V or 43.2 V)
		ON	<ul style="list-style-type: none"> Low Voltage Disconnect (LVD) = 11.5 V (23.0 or 46 V) Low Voltage Reconnect (LVR) = 12.6 V (25.2 V or 50.4 V) LVD Alarm = 11.8 V (23.6 V or 48.4 V)
6	Standby Mode	OFF	AC Output is always ON
		ON	AC Output is OFF unless a load > 8 W is detected
7	Ethernet Security (See Section 4.1 on page 37 for details)	OFF	150 W & 300 W Models: Not Used - Default is OFF 700 W to 2,500 W Models: Ethernet Write Disabled.
		ON	150 W & 300 W Models: Not Used - Default is OFF 700 W to 2,500 W Models: Ethernet Write Enabled.
8	Bluetooth Communication*	OFF	Bluetooth Disabled
		ON	Bluetooth Enabled

***Note:** Requires a power cycle when turning Bluetooth (BT) on with DIP Switch 8 during operation. BT can be turned off with DIP Switch 8 without a power cycle. All other DIP Switches can be changed during operation and the changes will immediately be implemented.

Table 2: Low Voltage Disconnect Settings (DIP 4 & 5)

Low Voltage Disconnect Factory Default & Presets (All Models)	12-volt Models			24-volt Models			48-volt Models		
	LVD	LVR	Alarm	LVD	LVR	Alarm	LVD	LVR	Alarm
Factory Default Settings (DIP 4 OFF)*	11.8	12.8	12.1	23.6	25.6	24.2	47.2	51.2	48.4
Preset Low (DIP 4 ON, DIP 5 OFF)	10.5	11.6	10.8	21.0	23.2	21.6	42.0	46.4	43.2
Preset High (DIP 4 ON, DIP 5 ON) *	11.5	12.6	11.8	23.0	25.2	23.6	46.0	50.4	47.2

***Note:** DIP 4 in the OFF position allows the factory-default values to be changed using the RS485 communication port or Bluetooth App, if needed. When DIP 4 is in the OFF position, it disables DIP 5. So when DIP 4 is in the OFF position, the position of DIP 5 is irrelevant.

2.5 Pluggable Terminal Block Installation for Remote Switch or Communications Wiring

If the application includes using a Remote Switch, 12 V Auxiliary Power, or EIA-485 communications Port, the pluggable terminal block that is included in the box will need to be installed. This will either be an 4-pin (150 W or 300 W models) or two 8-pin (700 to 2,500 W models) pluggable terminal block(s).

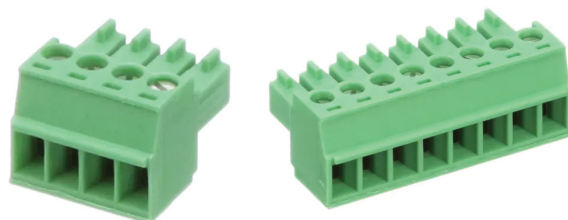

Figure 12: Pluggable Terminal Block (4-pin and 8-pin)

To install the Terminal Block:

1. Use a 1/8" (3.8 mm) flathead screwdriver to connect the wires to the pluggable terminal block before plugging it in. See Table 3 on page 16 for acceptable wire sizes and torque values.
2. Align the pins on the back of the terminal block with the holes in the SureSine Chassis on the DC Side of the unit.
3. Press into place. Ensure the terminal block seats firmly into place.

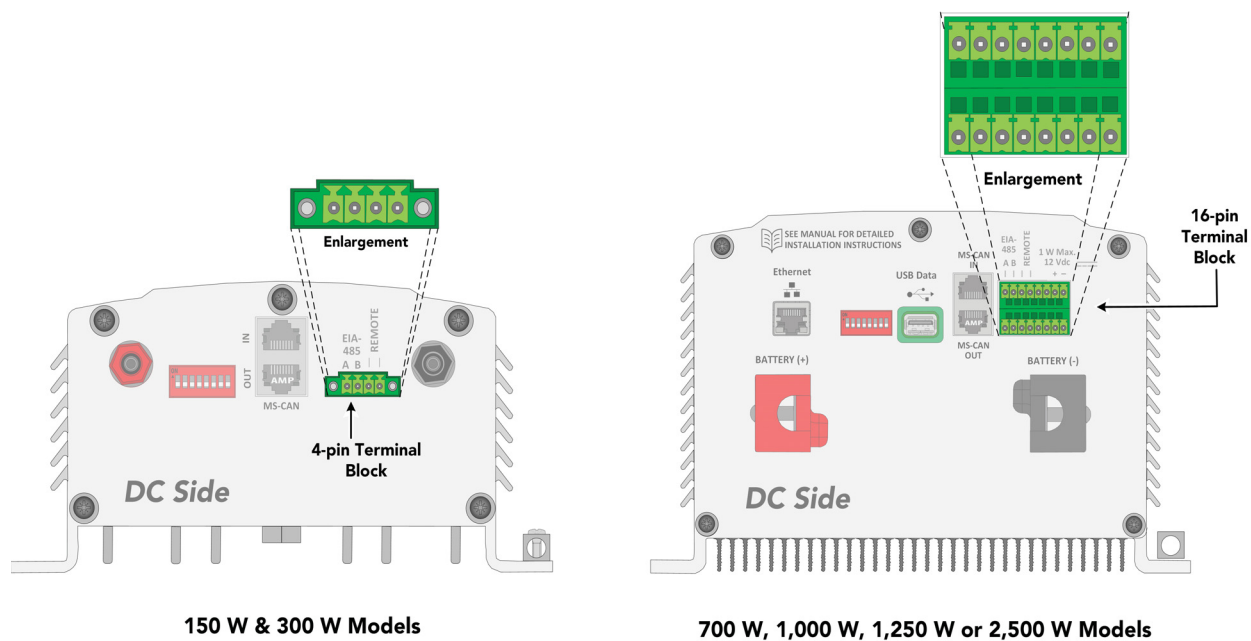

Figure 13: Terminal Block Installation

2.6 Remote Switch Installation (Optional)



IMPORTANT:

Check the AC Output Mode Switch on the AC end of the inverter and ensure it is in the REMOTE position before wiring. See Figure 28 on page 33.

If the site application requires a Remote ON/OFF Switch or relay dry contact, the following illustration shows where to connect the wires.

Note: Closed = ON and Open = OFF.

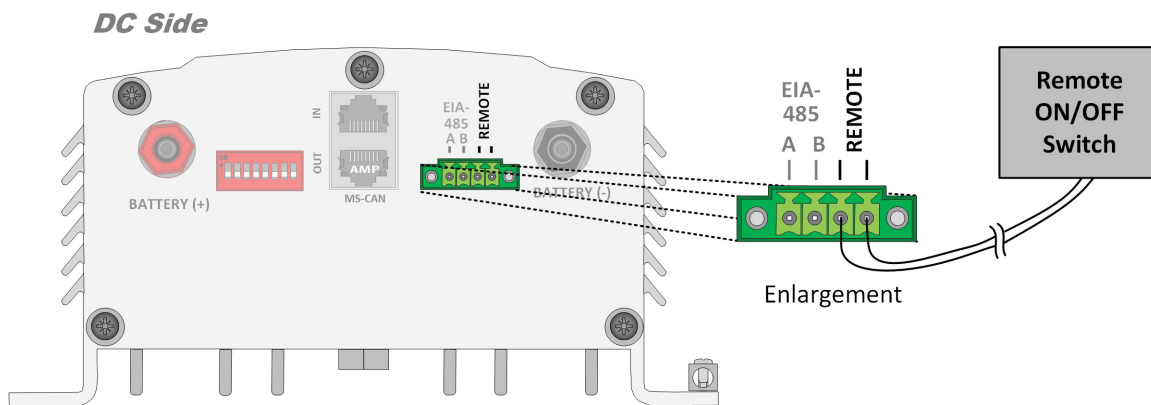

Figure 14: Remote Switch Wiring for 150 W to 300 W Models

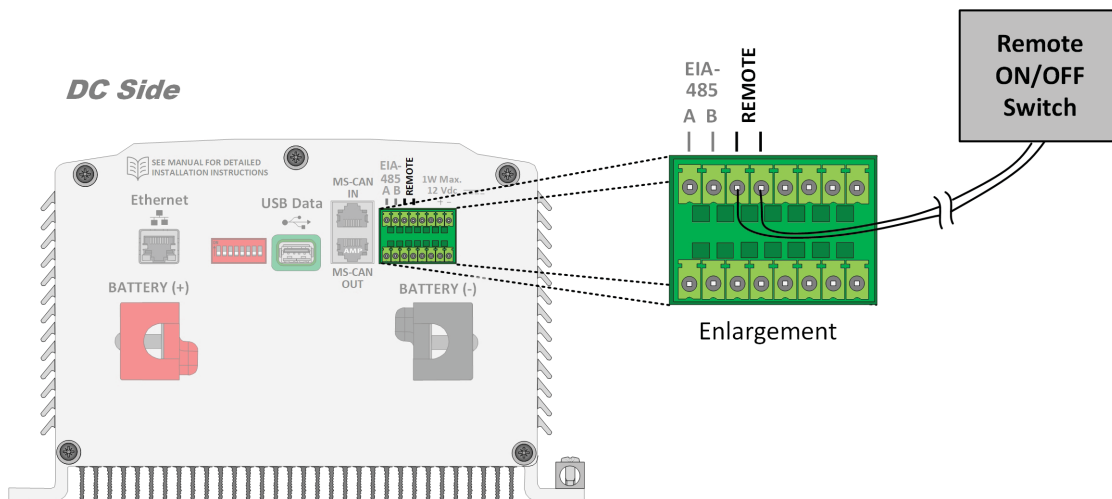

Figure 15: Remote Switch Wiring for 700 W to 2,500 W Models

2.7 Auxiliary Power (Optional)

Auxiliary Power for 1 W (Maximum), 12 Vdc applications is available on the 700 W to 2,500 W Models only. These types of applications include:

- EIA-485 Communication Bus.
- Small DC devices (e.g., LEDs).

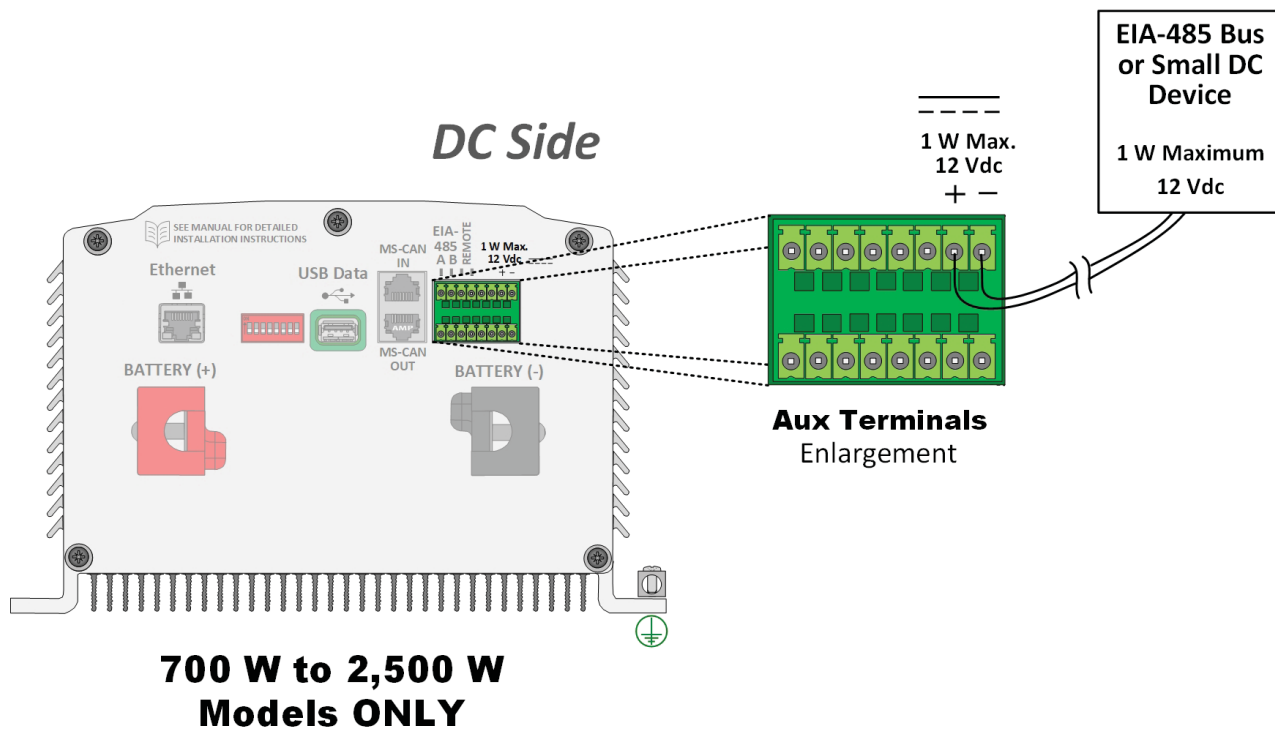





Figure 16: Auxiliary Power Terminals on 700 W to 2,500 W Models

2.8 Inverter Wiring

This section provides general instructions for connecting all the wiring for the inverter. This includes DC, AC, Neutral, and all Ground connections (system and chassis). Ensure **all** connections are made as required by local regulatory code.

	WARNING: SHOCK HAZARD
	<ul style="list-style-type: none"> • Installations must be performed by a qualified person trained in electrical safety procedures (minimum qualification). • All wiring must comply with local electric code requirements. • Ensure all sources of input are disconnected before connecting ANY cabling.
	WARNING: RISK OF FIRE
	<p>All over-current protection devices and wiring must be sized properly, in accordance with US National Electric Code (NEC) or the country of installation's local regulations.</p>
	CAUTION: EQUIPMENT DAMAGE
	<p>Do not connect the SureSine inverter's AC Output in parallel with any AC power sources. The SureSine inverter is not capable of synchronizing AC output phases. AC power from utility, generator, and inverter AC power can feed back into the unit and instantly damage the inverter and may also pose a fire and safety hazard.</p>

2.8.1 Terminal Torque Requirements

Tighten all connections as specified in Table 3.

Table 3: Terminal Torque Requirements

Terminal	Terminal Size or Wire Size	Torque to:	
		In-lbs.	Nm
DC (+) (-) Input Bolt Terminals (150 - 300 Watt) Note 1	M8 (~5/16")	20	2.3
DC (+) (-) Input Bolt Terminals (700 - 2,500 Watt) Note 1	M6 (~1/4")	35	4
AC Output Neutral, Line and Ground Terminals Note 2	M6 (~1/4")	20	2.3
Chassis Ground Lug Note 3	14 - 2 AWG (2.5 - 10.0 mm ²)	35	4
ModBus™, Remote Switch, Auxiliary Power Terminals	16 - 28 AWG (1.0 - 0.1 mm ²)	5	0.57
<p>Note 1 - Use properly sized ring terminals for DC power connections.</p> <p>Note 2 - Use properly sized slotted terminals or solid copper wire (#12 maximum) with AC Neutral, Line, and Ground bolt terminals.</p> <p>Note 3 - Use stranded copper wire with Chassis Ground stud.</p>			



2.8.2 Over-current Protection Requirements

WARNING: RISK OF FIRE

Fuses or circuit breakers are required in the DC battery circuit (all models) and in the AC output circuit (HW models) and shall be provided by the installer.

Locate battery breakers or fused disconnects for easy access and free from hydrogen gas/sulfuric acid fumes. The battery DC circuit breaker or fuse should be within 6 inches from the battery bank or as close as possible.

WARNING: SHOCK HAZARD

- Fuses, single-pole circuit breakers or single-pole disconnect switches should **NEVER** open grounded system conductors. This could create a shock hazard that could be fatal to personnel and/or damage the equipment.
- Fuses, single-pole circuit breakers, or single-pole disconnect switches must only be installed on ungrounded system conductors.
- It is acceptable to use double-pole breakers or double-pole disconnect switches which break both the grounded and ungrounded conductors with the SureSine inverter.

2.8.2.1 Recommended Battery Over-current Protection Device Sizing

Use Table 4 to determine the size of the over-current protection device required for the battery conductor.

Table 4: DC Battery Circuit Breaker/Fuse Size

Model Power Rating		Maximum Battery Continuous Current	Recommended Battery Breaker/ Fuse Rating
Watts	Volts DC		
150 W	12 Vdc	18 Amps	30 Amps
	24 Vdc	8 Amps	12-15 Amps
	48 Vdc	4 Amps	6-10 Amps
300 W	12 Vdc	36 Amps	60 Amps
	24 Vdc	16 Amps	25 Amps
	48 Vdc	8 Amps	12-15 Amps
700 W	12 Vdc	84 Amps	125 Amps
	24 Vdc	38 Amps	60 Amps
	48 Vdc	18.5 Amps	30 Amps
1,000 W	24 Vdc	54 Amps	80 Amps
	48 Vdc	26.5 Amps	40 Amps
1,250 W	24 Vdc	68 Amps	100 Amps
	48 Vdc	33 Amps	50 Amps
2,500 W	48 Vdc	66 Amps	100 Amps

2.8.2.2 Recommended AC Over-current Protection Device Sizing

Use Table 5 to determine the size of the over-current protection device required for the AC conductor.

Table 5: AC Circuit Breaker/Fuse Size

Model Power Rating	AC Output Maximum Continuous Current		AC Circuit Breaker/Fuse Ratings	
	120 Vac Model	230 Vac Model	120 Vac & 127 Vac Models	220 Vac & 230 Vac Models
150 W	1.25 Amps	0.7 Amps	2 to 5 Amps	2 to 5 Amps
300 W	2.5 Amps	1.3 Amps	4 to 5 Amps	3 to 5 Amps
700 W	5.8 Amps	3 Amps	10 Amps	5 Amps
1,000 W	8.3 Amps	4.3 Amps	15 Amps	7 to 10 Amps
1,250 W	10.5 Amps	5.4 Amps	15 Amps	10 Amps
2,500 W	21.0 Amps	11 Amps	30 Amps	20 Amps

2.8.3 DC and AC Conductor Sizing Requirements

It is critical that the ampacity (or current carrying capacity) of conductors is sufficient to handle the maximum current of the power circuits. Ensure that ring or slotted wire terminals have the proper wire size ratings for the wires being installed.

Table 6 and Table 7 show the minimum sizing requirements (for 75°C wire) of each SureSine model when operated at the maximum continuous current rating of the inverter. These sizing requirements are based on NEC 2021 [Table 310.15(b)(16)], ampacity for not more than three current-carrying conductors in a raceway, cable, or earth (buried), based on Ambient Temperature of 30°C (86°F).

Conductors rated for 90°C or in free air have higher ampacities and may provide smaller wire sizing than indicated in these tables. In addition, higher ambient temperatures reduce wire ampacity and increase the wire sizing requirements.

Voltage drops due to longer wire distances is another factor to be considered. Good system design generally requires larger wire sizes that limit voltage drop losses to 2% or less.



Use Table 6 to determine the minimum size for the DC Battery cables.

Table 6: Minimum Battery Cable Size - 75°C rated Copper

Model Power Rating	Wire in a Raceway, Cable, or Earth @30°C		
	12 Vdc Model	24 Vdc Model	48 Vdc Model
150 W	10 AWG	14 AWG	14 AWG
300 W	8 AWG	12 AWG	14 AWG
700 W	2 AWG	6 AWG	10 AWG
1,000 W	N/A	4 AWG	8 AWG
1,250 W	N/A	3 AWG	8 AWG
2,500 W	N/A	N/A	3 AWG

See Appendix A for more detailed wire sizing information including tables for 90°C copper wire, wiring in free air, higher ambient temperatures, and voltage drop distance tables for maximum 2% voltage drop in the DC battery cables.

Use Table 7 to determine the minimum size for the AC output wires.

Table 7: Minimum AC Output Wire Size - 75°C rated Copper

Model Power Rating	AC Wire Size	
	120 Vac & 127 Vac Models	220 Vac & 230 Vac Models
150 W	14 AWG (1 mm ²)	14 AWG (1 mm ²)
300 W	14 AWG (1 mm ²)	14 AWG (1 mm ²)
700 W	14 AWG (1.5 mm ²)	14 AWG (1.5 mm ²)
1,000 W	14 AWG (1.5 mm ²)	14 AWG (1.5 mm ²)
1,250 W	14 AWG (1.5 mm ²)	14 AWG (1.5 mm ²)
2,500 W	10 AWG (4 mm ²)	14 AWG (2.5 mm ²)

2.8.4 Grounding and Bonding Requirements

A proper grounding system is required for safety, equipment protection and electromagnetic noise reduction.

There must be a DC ground bond and a chassis equipment grounding connection. See Sections 2.8.5.1 and 2.8.5.2 for equipment ground and DC grounding electrode conductor wire sizing.

The DC input is isolated from the AC output and chassis so the inverter can have a positive or negative DC system ground depending on the application. DC system grounding is the responsibility of the installer.

2.8.4.1 AC Neutral-Ground Bond

An AC neutral-ground bond is required in North America. Therefore, all 120 Vac / 60 Hz models include, by default, an internal bond to earth ground as a factory connection between the AC neutral circuit and the metal chassis.

Note that removing the internal Neutral-Ground bond with a 120 V, 60 Hz model without an external neutral ground bond will void the certification.

For all other models (127 V, 230 V and 240 V), the AC output is floating, isolated from the chassis, with no neutral to ground bond between the neutral AC terminal and the metal chassis. If local code requires an AC neutral to ground bond or is otherwise required for the system with the 127 V, 230 V or 240 V models, there is an internal neutral-ground jumper wire (included) which can be used to connect the neutral terminal to the chassis.

When a neutral-ground bond is required with a SureSine model that has an AC receptacle, the internal neutral-ground jumper must be connected and the chassis must be bonded to ground.

2.8.4.2 Internal Neutral-Ground Bond vs. External Neutral-Ground Bond

When a neutral-ground bond is required with a SureSine model that has AC terminals, the neutral-ground bond can be connected internally or externally.

Having the internal neutral-chassis bond with the chassis bonded to ground provides a neutral-ground bond at the inverter AC power source and may be required by local code. However, an external neutral ground bond may be preferred or in some cases required.

An example of when an external neutral-ground bond may be required is for a system that has an external single pole AC transfer switch with another AC power source such as a generator or utility AC power so they share the same neutral-ground bond at all times.

If there is a double pole transfer switch which isolates both the line and neutral from another AC power source, the internal neutral-ground bond can be used with a separate neutral-ground bond for the other AC power source. This would be required with mobile applications (RV, marine etc.) where the inverter neutral is bonded to the vehicle or ship metal frame and grid (shore) power is bonded to the "shore" earth ground.

For 120 V / 60 Hz "-HW" (hardwired) models the neutral-ground jumper can be removed to allow for an external AC neutral bond to ground. Removing the internal Neutral Ground with a 120 V, 60 Hz model that have AC terminals without an external Neutral Ground bond will void the safety certification. Consult with local jurisdiction before removing any existing bonding jumper to ensure that it meets local code requirements.

Neutral-ground bond installation requirements are as follows.

- One and only one AC neutral-ground bond can be present in the system.
- There must be no internal ground bond if there is an external AC ground bond.
- Connecting or disconnecting the internal ground bond can only be performed by qualified personnel and requires tool access to the interior of the inverter.
- Removal of the internal neutral ground bond with 120 V / 60 Hz should only be done with models which include AC terminals.

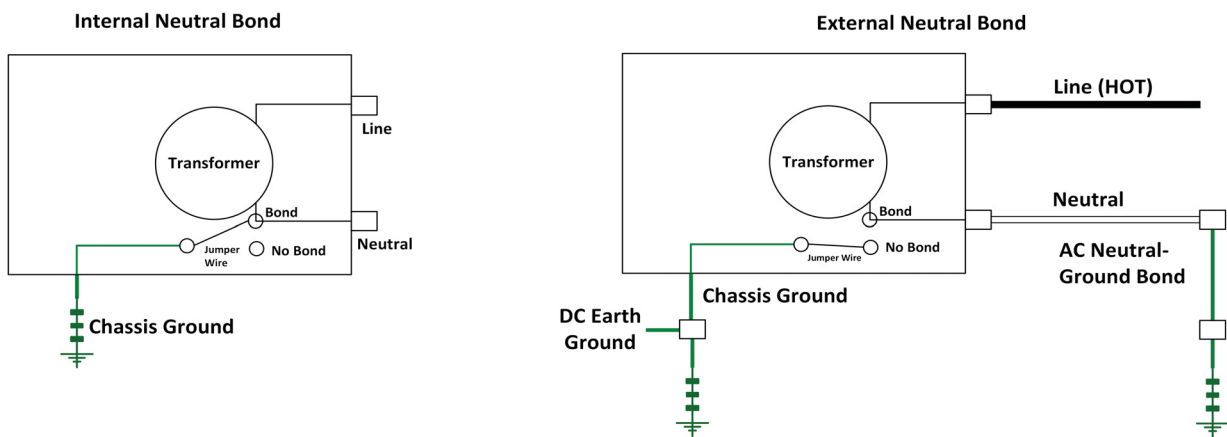

**Figure 17: Internal Grounded Neutral vs. External Grounded Neutral
(Internal Neutral Ground Bond removed)**

2.8.4.3 Internal Neutral-Ground Bond Jumper Wiring Instructions

SureSine Inverter Cover Removal:

1. The cover of the SureSine inverter needs to be removed in order to access the Neutral-Ground Bond Jumper wire terminals.
2. Lay the SureSine inverter on a flat surface with no wires connected to the inverter. Ensure that no DC power wires are connected to the DC terminals before removing the cover.
3. Remove the five (5) screws of the AC faceplate to detach it from the inverter.
4. Then remove the top three (3) screws of the DC faceplate and pull the top plate off from the inverter if required.
5. The jumper wire is connected to the AC neutral and chassis screws as indicated in Figure 19 and Figure 20. Use a torque of 22 in-lbs / 2.5 Nm when replacing screws.



Figure 18: Neutral-Ground Jumper Wire

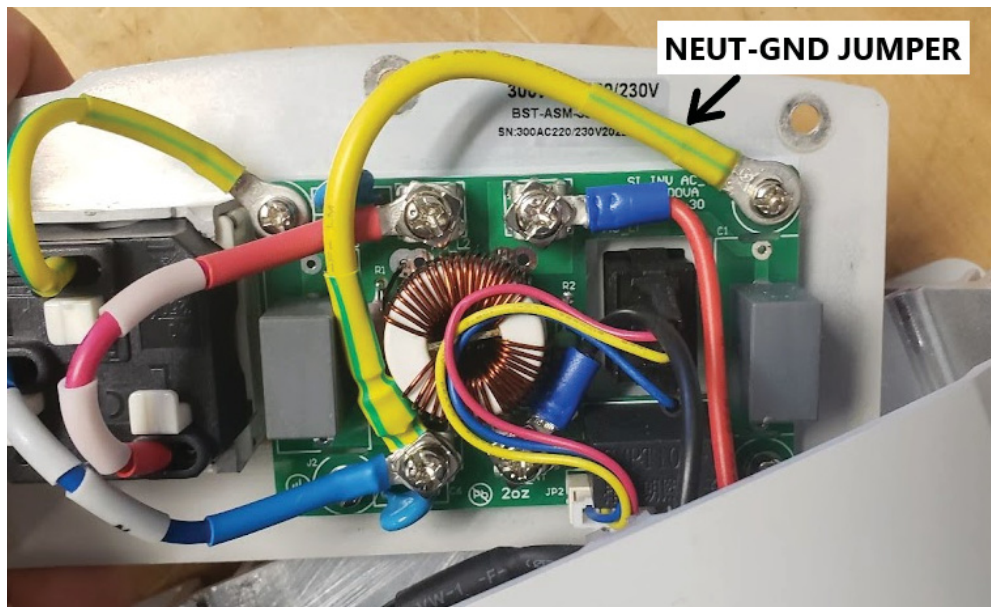

Figure 19: 150 to 300 W Internal Neutral-Ground Jumper

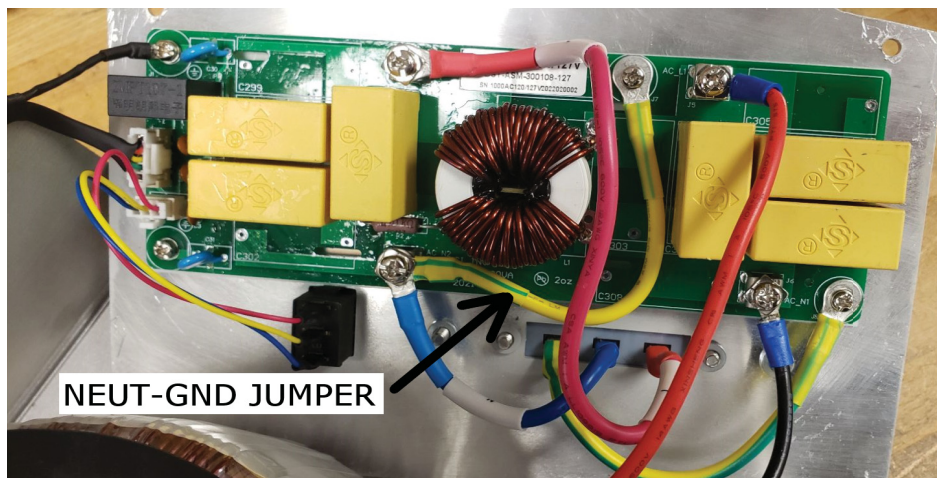

Figure 20: 700 to 2,500 W Internal Neutral-Ground Jumper

Replacing the SureSine Inverter Cover:

1. Place the top cover of the inverter with the slotted edges fully inserted into the groves of the chassis. The cover may need to be pushed into place with a good deal of pressure to fully seat it to the chassis.
2. Insert and tighten the five (5) screws at the top of the DC faceplate attaching it to the top chassis cover. Do not tighten any of the screws to torque before they are all inserted correctly to avoid stripping the screws.
3. Place the AC faceplate back onto the end of the chassis and insert and tighten the (5) 5 screws securing it to the chassis. Do not tighten any of the screws to torque before they are all inserted correctly to avoid stripping the screws.

2.8.5 Grounding Connections

U.S. installed grounding systems must conform to all U.S. National Electrical Code (NEC) requirements, and/or to any local regulations. Non-U.S. grounding systems must meet all national and local requirements of the country of installation.

NOTE: Resistive-earthed systems are acceptable.

Use only one grounding electrode unless multiple grounding electrodes are reliably bonded together.

All grounding conductors must conform to local codes and regulations.

NOTE: Conductors identified by the color green (or green and yellow) shall only be used for grounding purposes.

Interrupt all power input to the SureSine before working on the grounding system.

2.8.5.1 Chassis Ground

The SureSine chassis grounding terminal is located on the outside of the case as shown in the DC wiring diagrams in Section 2.8.6. Use copper wire to connect the chassis grounding terminal, and other dead metal, to earth ground. A ring wire terminal is required for stranded copper wiring. A terminal is not required for solid copper wiring.

Use Table 8 to size the equipment grounding wire for the chassis based on the DC over-current protection rating per NEC requirements.

Table 8: Minimum Wire Sizes for Copper Ground Cable

Over Current Protection Device Rating (Amps)	Minimum Copper Wire Size (AWG / mm ²)
15	#14 / 2.08
20	#12 / 3.31
30-60	#10 / 5.26
100	#8 / 8.36
200	#6 / 13.3

If the equipment ground wiring is combined with other equipment grounding wiring to a common bus bar, the equipment grounding wire sizing requirement from the bus bar to ground is sized to the highest over-current protection rating of the DC System.

2.8.5.2 DC System Ground

Ensure that the DC system ground is properly bonded to ground.

NEC Section 250.166(B) states that the DC Grounding Electrode Conductor (GEC) must be sized not smaller than the largest DC conductor in the system, and not smaller than the 8 AWG. However, NEC Section 250.166(C) indicates that for DC GEC connections to rod, pipe, or plate grounding electrodes, #6 AWG is adequate.

If the system grounding and equipment grounding is combined to a common bus bar, the earth ground wiring must be sized to the larger of the two.

The internal AC neutral-ground bond is grounded with the chassis equipment grounding.

If the AC Neutral internal bond jumper is removed, an external AC neutral-earth bond is required. For details, refer to Figure 17 in Section 2.8.4.2.



2.8.6 DC Connections

DC Connections will vary by site application. The SureSine Inverter can support 12-volt, 24-volt, and 48-volt battery systems.



WARNING: HAZARDOUS CURRENT, RISK OF FIRE OR EXPLOSION

- Do NOT allow the positive (+) DC cable to touch the Negative (-) DC cable. Allowing these cables to touch can create dangerous current or a possible fire/explosion hazard.
- Locate battery breakers or fused disconnects for easy access and free from hydrogen gas/sulfuric acid fumes. The battery DC circuit breaker or fuse should be within 6 inches from the battery bank or as close as possible.



IMPORTANT:

- Since battery banks can vary widely, the DC wiring illustrations do not show individual batteries or their connections. Consult the system designer and installer for proper cabling of the specific site configuration.
- Be certain that the battery connection is made with correct polarity. The SureSine has battery reverse polarity protection implemented with an internal fuse which will have to be replaced if connected with reverse polarity.
- Secure the cable to the battery bank following industry Best Practices. Hardware may vary depending on site application and local regulatory code.
- Measure the voltage on the open battery wires BEFORE connecting to the SureSine. Ensure the correct voltage of the battery is used with the selected model to be installed.
- A circuit breaker or fuse is required in the ungrounded battery cable. See Section 2.8.2 Over-current Protection Requirements for more information.
- Refer to Section 2.8.2 Over-current Protection Requirements for recommended DC battery circuit breaker/fuse ratings and Section 2.8.3 DC and AC Power Wire Sizing Requirements for DC battery wire sizing.
- Use a proper crimping Tool to crimp the terminals to the bare ends of the wires where required. Connections should be tight so they can't slide out.

2.8.6.1 Negative Grounding

For wiring diagrams showing **NEGATIVELY** grounded DC Wiring:

- **For 150 W & 300 W Models:** See Figure 21 on page 27
- **For 700 W, 1,000 W, 1,250 W & 2,500 W Models:** See Figure 23 on page 28

2.8.6.2 Positive Grounding

For wiring diagrams showing **POSITIVELY** grounded DC Wiring:

- **For 150 W & 300 W Models:** See Figure 22 on page 27
- **For 700 W, 1,000 W, 1,250 W & 2,500 W Models:** Figure 24 on page 28

2.8.6.3 DC Wiring Procedure

STEP 1. Before wiring, verify that all breakers are in the open/disconnected position, and that all fuses are removed from the holders.

STEP 2. Connect a battery cable between the **grounded** battery bank post (–) for a negative grounded system or (+) for a positive grounded system) and inverter battery terminal of the same polarity.

STEP 3. Connect a battery cable to the **ungrounded** DC input terminal (+) for a negative grounded system or (–) for a positive grounded system).

STEP 4. Wire a breaker or in-line fused disconnect switch in the ungrounded battery cable no further than 12" (305 mm) from the ungrounded battery post. When wiring a fused disconnect switch, make sure the fuse is between the battery and the switch. Make sure the breaker or disconnect switch is in the OPEN position. **Do not connect the ungrounded battery cable to the battery at this time.**



WARNING: SHOCK HAZARD

Do not close the battery breaker or disconnect switch until all system wiring is completed.

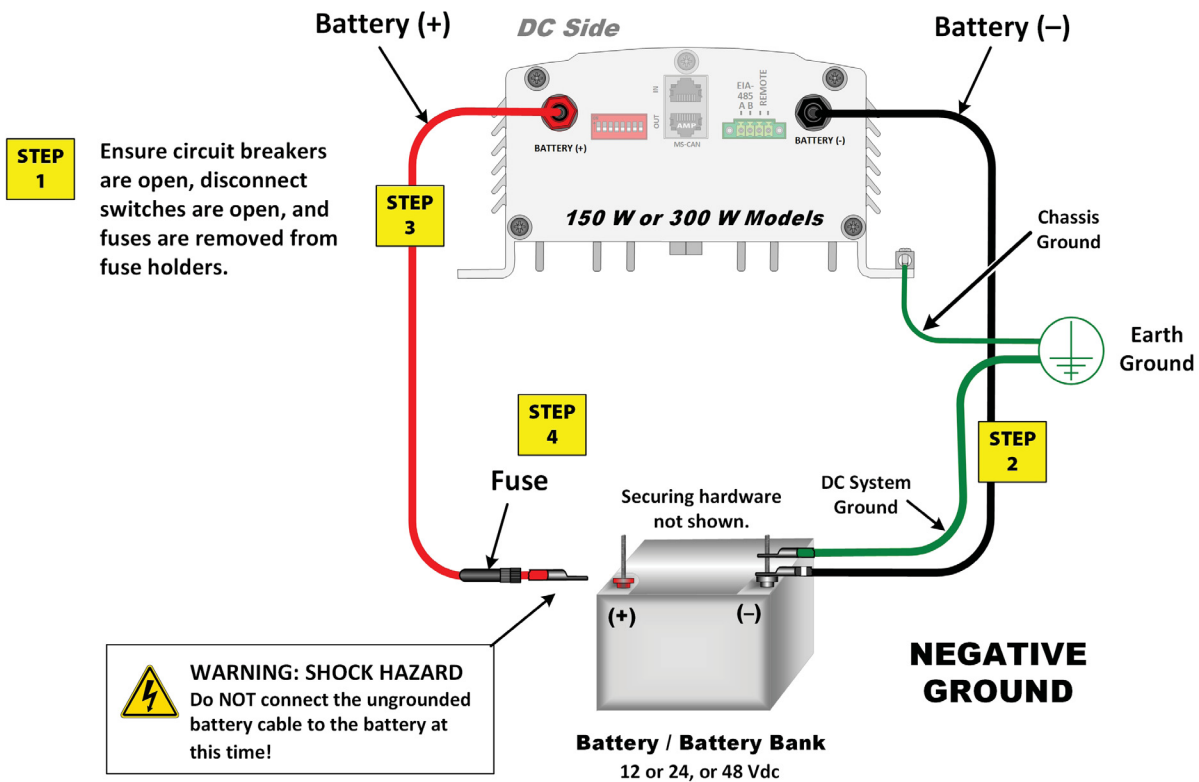

Figure 21: DC Connections on 150 W & 300 W Models with Negative Grounding

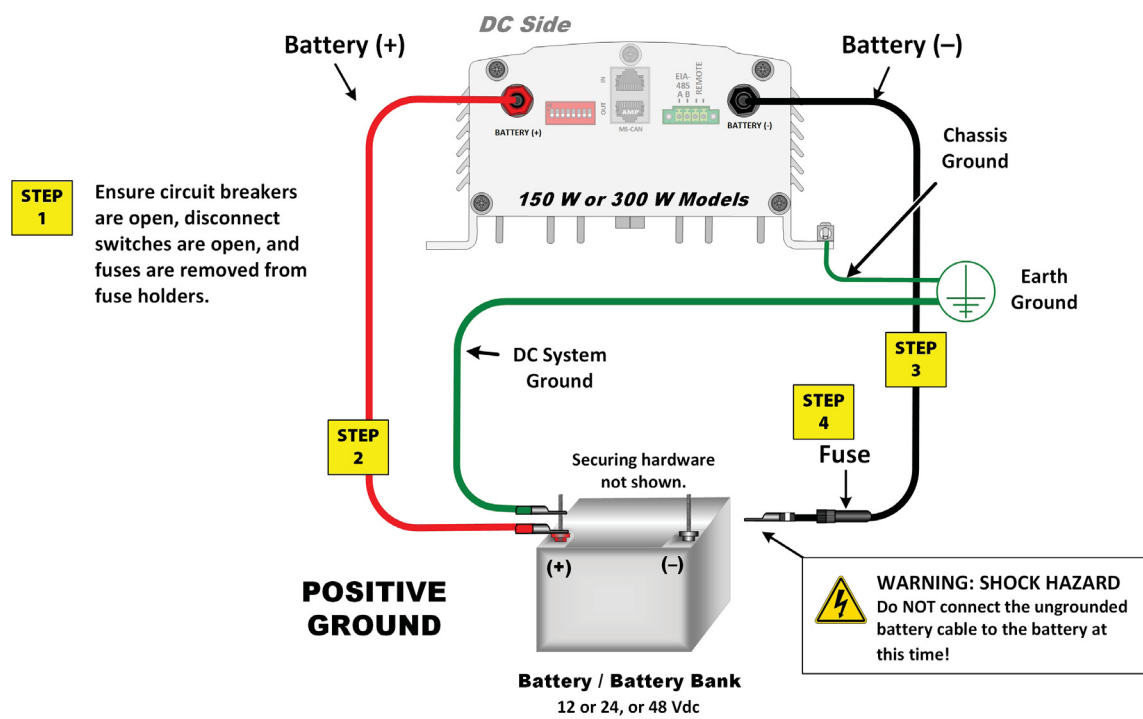

Figure 22: DC Connections on 150 W & 300 W Models with Positive Grounding

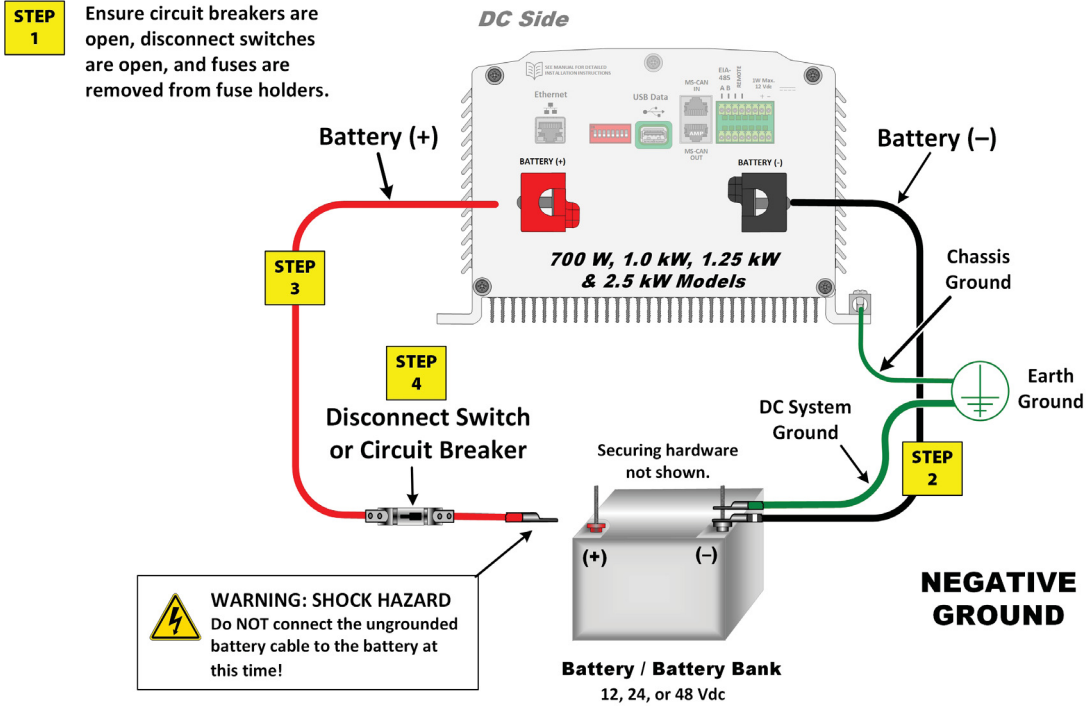

Figure 23: DC Connections on 700 W to 2,500 W Models with Negative Grounding

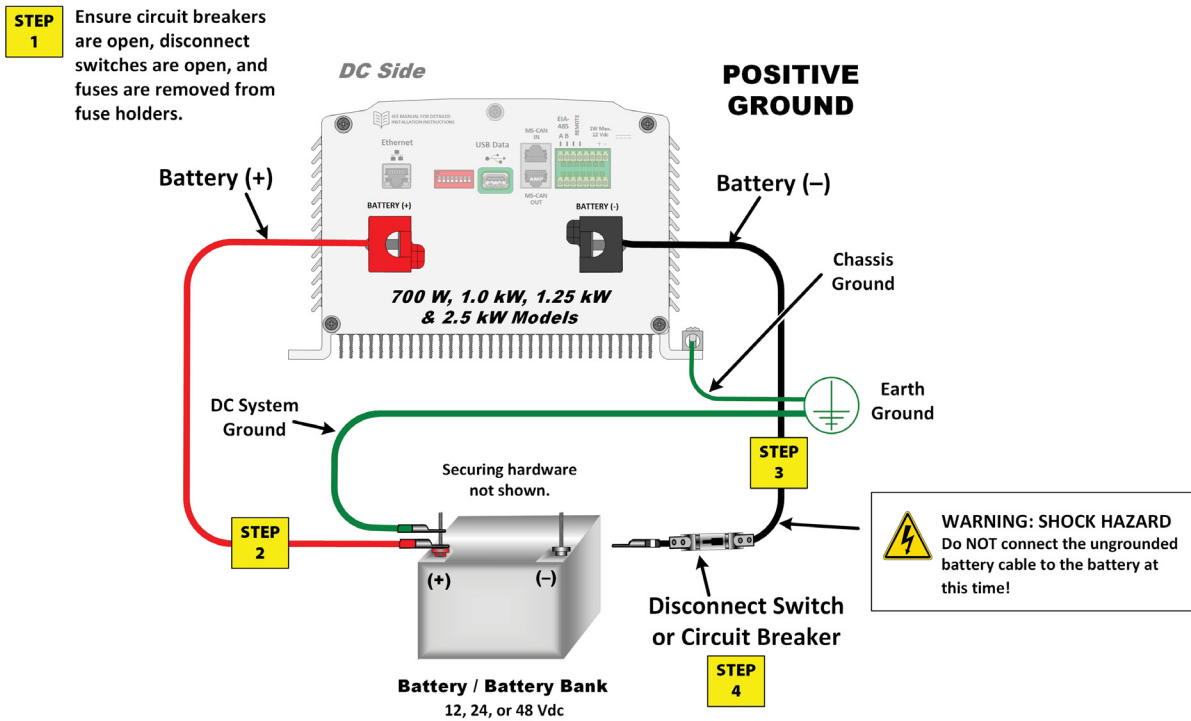

Figure 24: DC Connections on 700 W to 2,500 W Models with Positive Grounding

2.8.7 AC Connections

WARNING: SHOCK HAZARD



This unit is not provided with a GFDI device. This inverter must be used with an external GFDI device as required by the Article 690 of the National Electrical Code for the installation location.

CAUTION: EQUIPMENT DAMAGE



- AC loads should not exceed the continuous and surge power ratings. Exceeding these ratings could cause a fault and shut off the inverter. Loads that have inrush currents that can exceed the highest power surge current rating could damage the inverter.
- There are many types of loads that have high starting surges including pumps, fans, refrigerator or air conditioner, air compressors, electric motors, switched mode power supplies, and power tools. These loads can have a power surge of 2 to 5 times the running power of the load or even higher. If the manufacturer does not provide a surge rating for the load, check with the manufacturer or multiply the maximum power by an appropriate sizing factor for the type of load being used. If there are other loads in the system, the surge power requirement must be added to the total running power of the other loads in the AC system.
- Observe AC output voltage and frequency markings on the SureSine. Be sure AC loads are compatible for proper load operation and to avoid damage to loads and/or inverter.

Models which include AC terminals require permanent, hardwired AC connections. This may require additional hardware such as sub-panels, circuit breakers, fuses, disconnect switches or ground-fault circuit interrupter (GFCI) breakers or outlets. **AC wiring must comply with local regulatory code for the specific site.**

No additional AC wiring is required with models that come factory wired with an AC outlet. A Ground Fault Interrupter power strip or plug-in outlet is recommended.

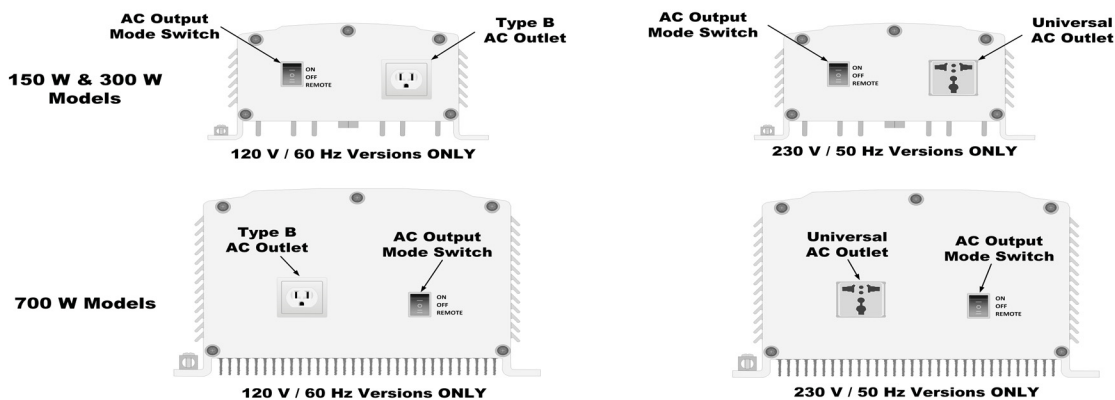

Figure 25: AC Connections on 150 W, 300 W, & 700 W Models (with Factory Wiring)

2.8.8 AC Wiring

The 150 W, 300 W, and 700 W Models comes either factory-wired or have the option of being hardwired. The 1,000 W , 1,250 W, and 2,500 W Models require permanent, hardwired connections. **Wiring must comply with local regulatory code for the specific site.**



WARNING: RISK OF FIRE

Ensure wire sizes comply with local regulatory code.



IMPORTANT:

- A circuit breaker or fuse is required on the hot AC line wire near the inverter.
- Refer to Section 2.8.2 for recommended AC circuit breaker/fuse ratings
- Refer to Section 2.8.3 DC and AC Power Wire Sizing Requirements for AC wire sizing.
- Use a proper crimping tool to crimp the terminals to the bare ends of the wires where required. Connections should be tight so they can't slide out.
- There must be one and **only one AC neutral ground bond**. Do not install The SureSine inverter with an external neutral-ground bond unless the internal neutral-ground bond has been removed. Refer to Section 2.8.4.1 for details.

A three-conductor copper cable with at least a 75°C insulation rating can be used for wiring the AC circuits.

2.8.8.1 AC Wiring Procedure

STEP 1. Before wiring, verify that the AC Output Mode Switch is in the Center/ OFF position, all breakers in the system are in the open/ disconnected position, and all fuses are removed from the holders.

STEP 2. Connect the earth/ ground wire between the Earth terminal of the SureSine inverter and the earth ground connection of the AC device, AC receptacle, or AC distribution panel.

STEP 3. Connect the AC Neutral wire between the AC neutral terminal of the SureSine inverter and the neutral connection of the AC receptacle or AC distribution panel. Ensure that the distribution panel does not have a neutral ground connection.

STEP 4.

- a. Connect the AC line wire between the AC Line terminal of the SureSine inverter and the fuse or AC circuit breaker.
- b. Then connect another wire between the fuse or AC circuit breaker and the line connection of the AC receptacle or AC distribution panel.

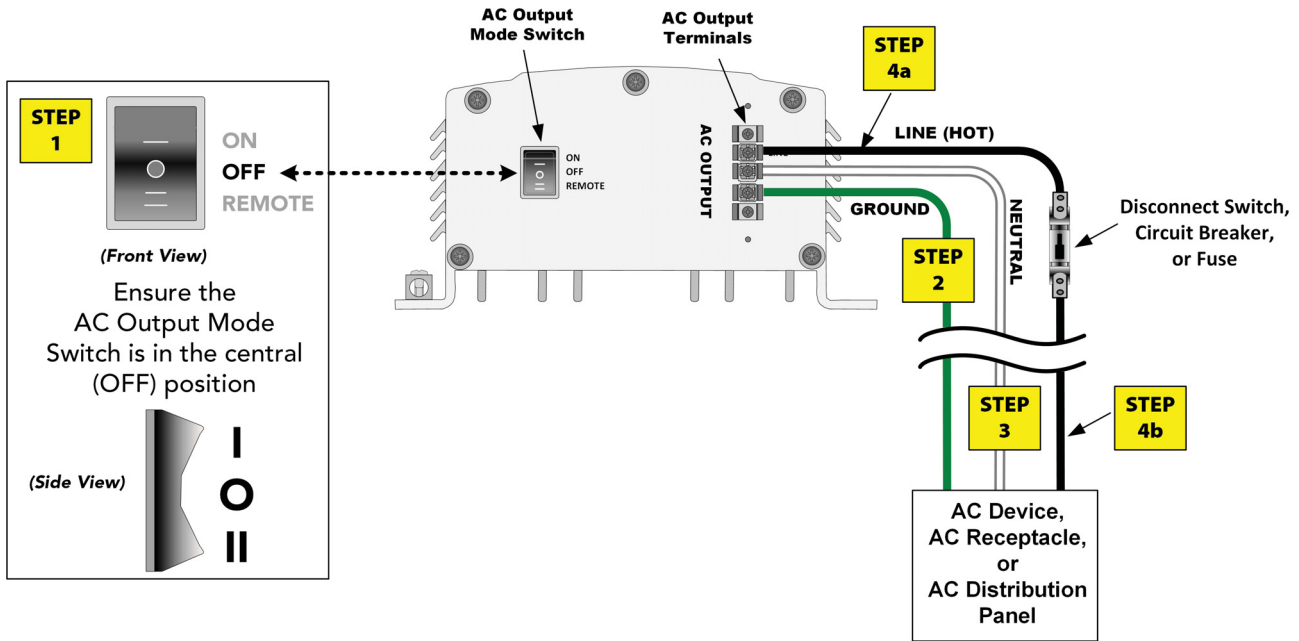

Figure 26: AC Wiring for 150 W or 300 W Models

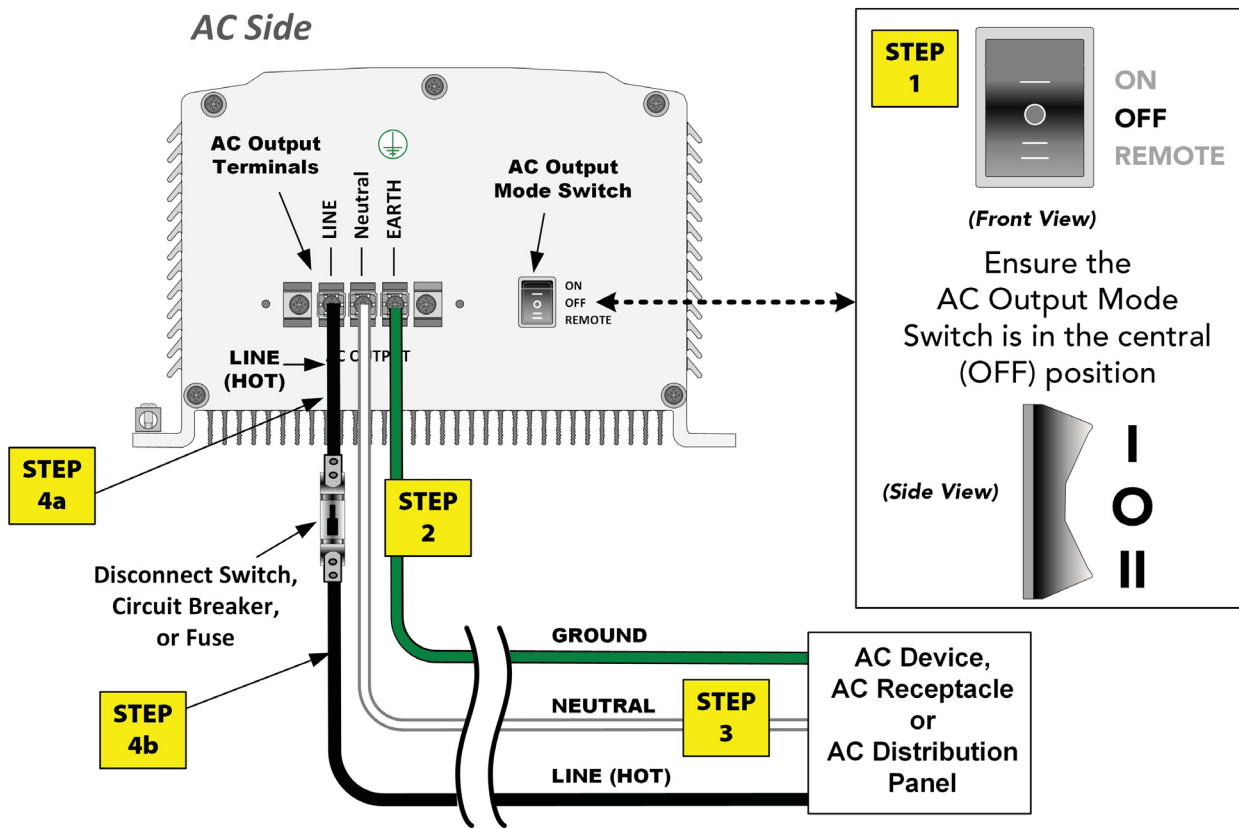



Figure 27: AC Wiring for 700 W, 1,000 W, 1,250 W or 2,500 W Models

2.9 Check Wiring and Power Up

1. Review wiring steps and double-check all wiring and connections.
2. Verify that the battery is wired with correct polarity to the SureSine.
3. Connect the ungrounded battery cable to the ungrounded battery post.

	WARNING: RISK OF EXPLOSION
<p>Connecting the battery to the SureSine with the breaker or disconnect closed will cause a spark at the point of connection. There is a RISK OF EXPLOSION in hazardous areas or locations where explosive gases have accumulated.</p>	

4. Close the battery breaker or disconnect switch to power up the inverter.
5. One of the SureSine LEDs will flash red during startup and then the Status LED should illuminate solid Green indicating successful startup and no faults.
6. Use the SureSine AC Output Mode Switch to turn on and off the AC output of the inverter. See Table 9 on page 32 for the AC output power status LED.

3.0 OPERATION

3.1 LED Indications

Two Light Emitting Diodes (LEDs) are on the front of the unit to provide Status and AC Output Status. Table 9 defines what the LEDs represent.

Table 9: LED Indications

STATUS LED ¹	AC Output LED	Operation or State
OFF ●	OFF ●	No power or Battery below 9.5 V
GREEN ●	OFF ●	AC Output OFF
GREEN ●	GREEN ●	AC Output ON
GREEN ●	GREEN (BLINK) ² ●	AC Standby Mode
GREEN ●	RED (BLINK) ² ●	Low Voltage Disconnect (LVD) Warning
GREEN ●	RED ●	Low Voltage Disconnect (LVD)
RED ●	RED (BLINK) ² ●	Inverter or System Fault ³ (Recoverable)
RED ●	RED ●	Inverter or System Fault ³ (Critical Fault. Requires a reboot.)

¹ The Status LED flickers ON very briefly when the LED is OFF. The Status LED flickers OFF very briefly when the LED is GREEN or RED solid. The "heartbeat" occurs every 5 seconds.

² 0.5 Hz. Rate

³ See Section 3.4 on page 34 for more information concerning faults.

3.2 Ethernet Jack LEDs

In addition to the STATUS and AC Output LEDs, two (2) small LEDs can be found on the Ethernet RJ-45 jack. These LEDs indicate the LAN/WAN network link and activity status as follows:

Table 10: Ethernet Jack LED Indications

Condition	Green LED	Yellow LED
Network Connection OK	ON	OFF
Network Activity	ON	Blinking
Error	OFF	ON

3.3 AC Output Mode Switch Operation

The AC Output Mode Switch will always turn the inverter on directly in the ON (up) position. To enable ON/OFF control with a wired remote switch or a communication command (digital command), the switch must be in the REMOTE position. Select remote switch or digital command using DIP Switch # 1.

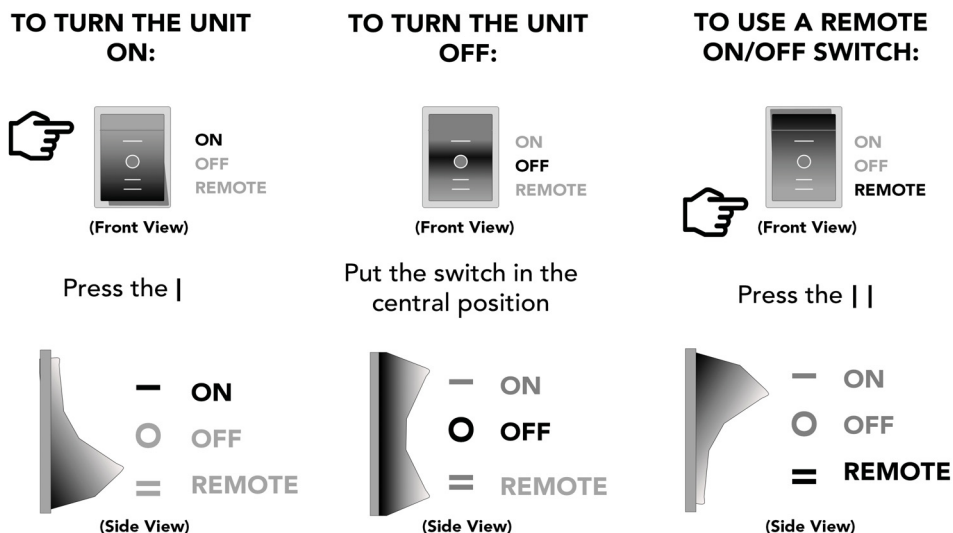

Figure 28: AC Output Mode Operation and Bluetooth Activation

3.4 Protections

3.4.1 Low Voltage Disconnect (LVD)

The SureSine will disconnect AC Output when the battery discharges below the Low Voltage Disconnect (LVD) set point (after a 4-minute delay). AC Output will resume when the battery has recharged to Low Voltage Reconnect (LVR) set point. The LVD/LVR thresholds are adjustable using DIP Switch 4. See "Adjusting Settings" on page 11 for details.

Audible LVD Warnings:

- The SureSine will beep four (4) times when the battery discharges to the LVD Warning threshold voltage.
- The SureSine will beep twice when Low Voltage Disconnect occurs.
- The LVD Warning occurs 0.3 V above the selected LVD threshold.

3.4.2 High Voltage Disconnect (HVD)

The SureSine will shut down and disconnect AC Output if battery voltage exceeds 15.5 V. It will automatically reconnect when the battery voltage decreases to 14.5 V.

3.4.3 High Temperature Disconnect (HTD)

If the SureSine heat sink temperature rises above 95°C, an HTD fault will occur and the SureSine will disconnect the AC Output. Normal operation will automatically resume when the heat sink cools to 80°C.

3.4.4 Over Current and Short Circuit Protection (Critical Fault)

The SureSine inverter has full electronic protection against AC overloads and short circuits on AC Output. Three (3) automatic retries will be attempted every 10 seconds.

If a short circuit still persists after three (3) retries, the fault must be manually cleared in one of the following ways:

- a. Disconnect, then reconnect battery power.
- b. Use the SureSine Utility Mobile app to send a Reset command.

3.4.5 Reverse Polarity Protection

The SureSine inverter includes two (2) or three (3) internal 40 A fuses (depending on the model) for protection against reverse polarity. If the SureSine is unable to power on when DC power is connected, there is a possibility of a blown fuse caused by DC reverse polarity or over-current. See Section "6.3 Fuse Replacement" for instructions on how to check and replace the internal fuses.

4.0 COMMUNICATION OPTIONS

The SureSine Inverter line provides communication options to monitor system data and control operations using a computer or mobile device.

The SureSine Inverter comes with the following communication options:

- All Models:
 - Bluetooth for wireless communication to a computer or mobile device
 - EIA-485 for connection to a ModBus™ EIA-485 serial network with other devices in the system which may include other SureSine inverters, Morningstar products, and 3rd-party equipment
 - (Future Feature Improvement) MS-CAN (Morningstar Communication Area Network) for a wired communication connection to other Morningstar products
 - Figure 29 shows the location of the communication ports for the 150 W and 300 W models.
 - Figure 30 shows the locations of the communication ports for the 700 W to 2,500 W models.
- 700 W to 2,500 W Models Only:
 - Ethernet (for ModBus TCP/IP™ connection over WAN/LAN)
 - USB Data Port for ModBus™ serial communications to a PC

Figure 29 shows the location of the communication ports for the 150 W and 300 W models.

Figure 30 shows the locations of the communication ports for the 700 W to 2,500 W models.

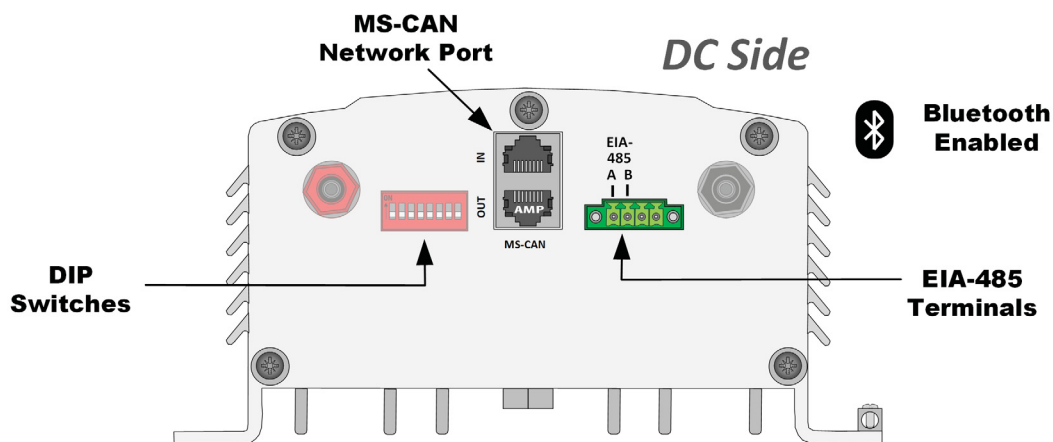

Figure 29: Communication Port Locations (150 W & 300 W Models)

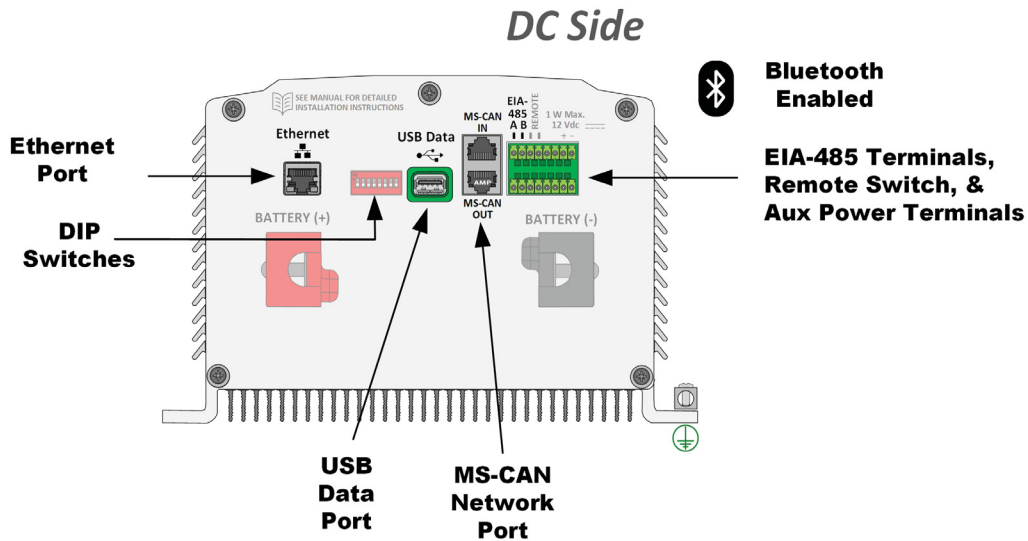

Figure 30: Communication Port Locations (700 W to 2,500 W Models)

ModBus™ and ModBus TCP/IP™ are non-proprietary open standard protocols for serial and Ethernet networks. The ModBus™ specification document is available from the SureSine Product page at <https://www.morningstarcorp.com/products/suresine/>. The ModBus™ specification document provides details on register locations, scaling, and variable definitions. ModBus™ software can be used to monitor, control and program the SureSine inverter.

The factory default Modbus ID = 1

Using communication options may require changing DIP Switch 7 for Ethernet Security and/or DIP Switch 8 to enable the Bluetooth feature.

- See Table 1 on page 12 for details on DIP Switch Settings.
- See Section 4.1 for details about Ethernet Security.
- See Section 4.2 for information about the Bluetooth feature.

4.1 Ethernet Security

When DIP switch 7 is set to disabled, write commands over Ethernet to the SureSine are not allowed. This includes the control commands (on/off, reset control, etc) and adjustments to custom set points and network settings. It does not affect remote monitoring over Ethernet.

Write commands are always enabled with the EIA-485 or USB local serial ports. DIP Switch 7 also does not affect the ability to change custom settings or send commands using the Bluetooth app.

This is a safety feature to prevent unintended changes to custom settings, but it is not a replacement for proper network security.

4.2 Bluetooth

Bluetooth is for connecting a mobile device to the SureSine Inverter. **DIP Switch #8 must be enabled (ON) for this feature to function.** See Section 2.4 on page 11 for details on enabling this feature.

4.2.1 To Connect the SureSine using Bluetooth

1. Set the AC Output Mode Switch to REMOTE.
2. Make sure the Bluetooth feature on your digital device is turned ON.
3. See Section 4.2.2 on page 39 for instructions on downloading and installing the SureSine Utility Mobile App to your digital device.
4. Use the SureSine Utility mobile app to control and monitor the activities of the SureSine Inverter.

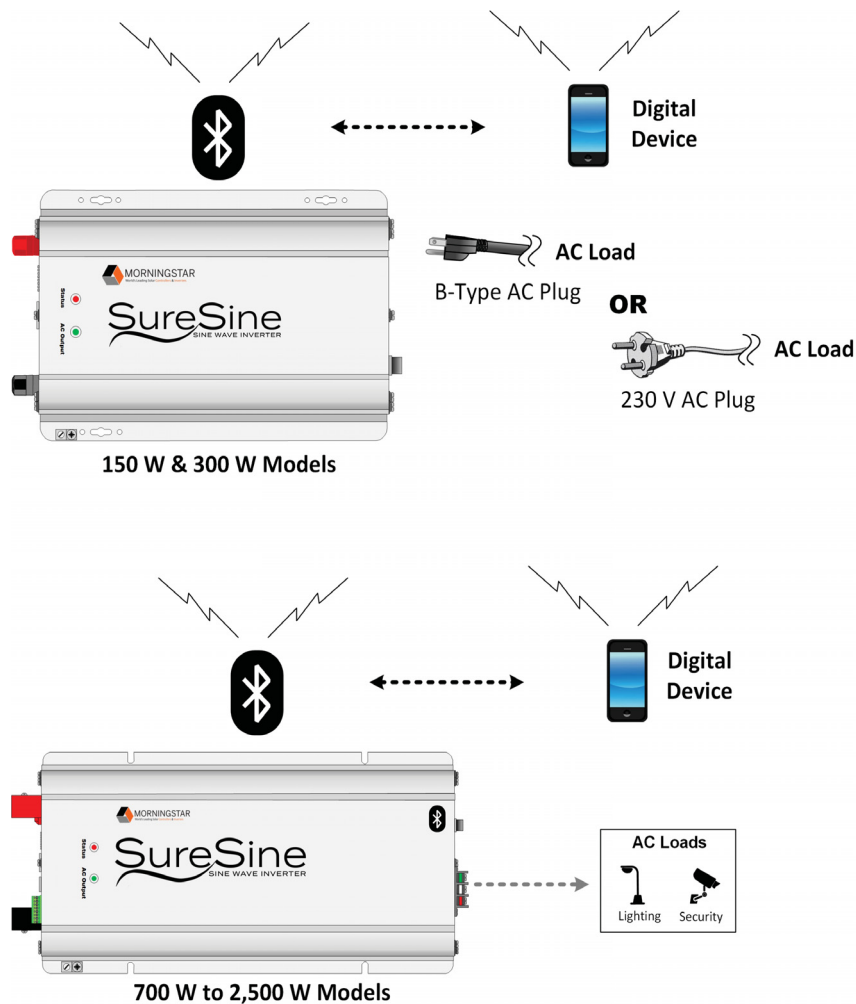

Figure 31: Communication using Bluetooth



4.2.2 SureSine Mobile Utility App

The SureSine inverter has a Mobile Utility App available for monitoring and settings adjustments, and firmware updates. This app is designed for Android and Apple devices and connects using Bluetooth. See Section 5.0 for firmware update information.

The SureSine Mobile Utility App is available at Google Play and Apple App stores.

https://play.google.com/store/apps/details?id=com.zkrs.suresine&hl=en_US&gl=US

<https://apps.apple.com/in/app/suresine-utility/id6449495674>

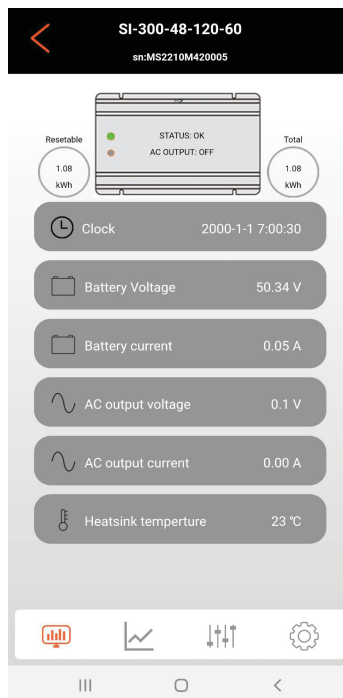

Figure 32: SureSine Utility Mobile App (Main Dashboard)

A password is required to access the control, settings and firmware update screens in the mobile utility app.

- The password is **141**.

4.3 Ethernet (for ModBus TCP/IP™)

The Ethernet port provides an interface between the SureSine inverter and a LAN/WAN network or the Internet. The SureSine supports Ethernet communications using ModBus TCP/IP™ protocol..

The RJ-45 Ethernet jack features two (2) indicator LEDs for connection status and network traffic.

The Factory Default Network Settings are as follows.

- IP 192.168.1.253
- Subnet Mask 255.255.255.0
- Gateway 192.168.1.1
- Primary DNS Server 192.168.1.1
- Secondary DNS Server 192.168.1.1
- ModBus™ TCP/IP Port 502

The controller's MAC Address is located on the serial label on the side of the controller.

The factory default ModBus ID = 1.

The Network Settings can be changed using ModBus™.



4.3.1 To Connect to a Local Area Network or to the Internet

1. Insert one end of a CAT5, CAT6, or CAT7 cable into the Ethernet port on the SureSine Inverter.
2. Insert the other end of that cable into a router or Ethernet Switch.
3. Connect using the ModBus™ software of choice.
The factory default ModBus™ ID = 1.

A network diagram is shown in Figure 33. The SureSine can also be connected directly to a PC using an Ethernet cross-over cable.

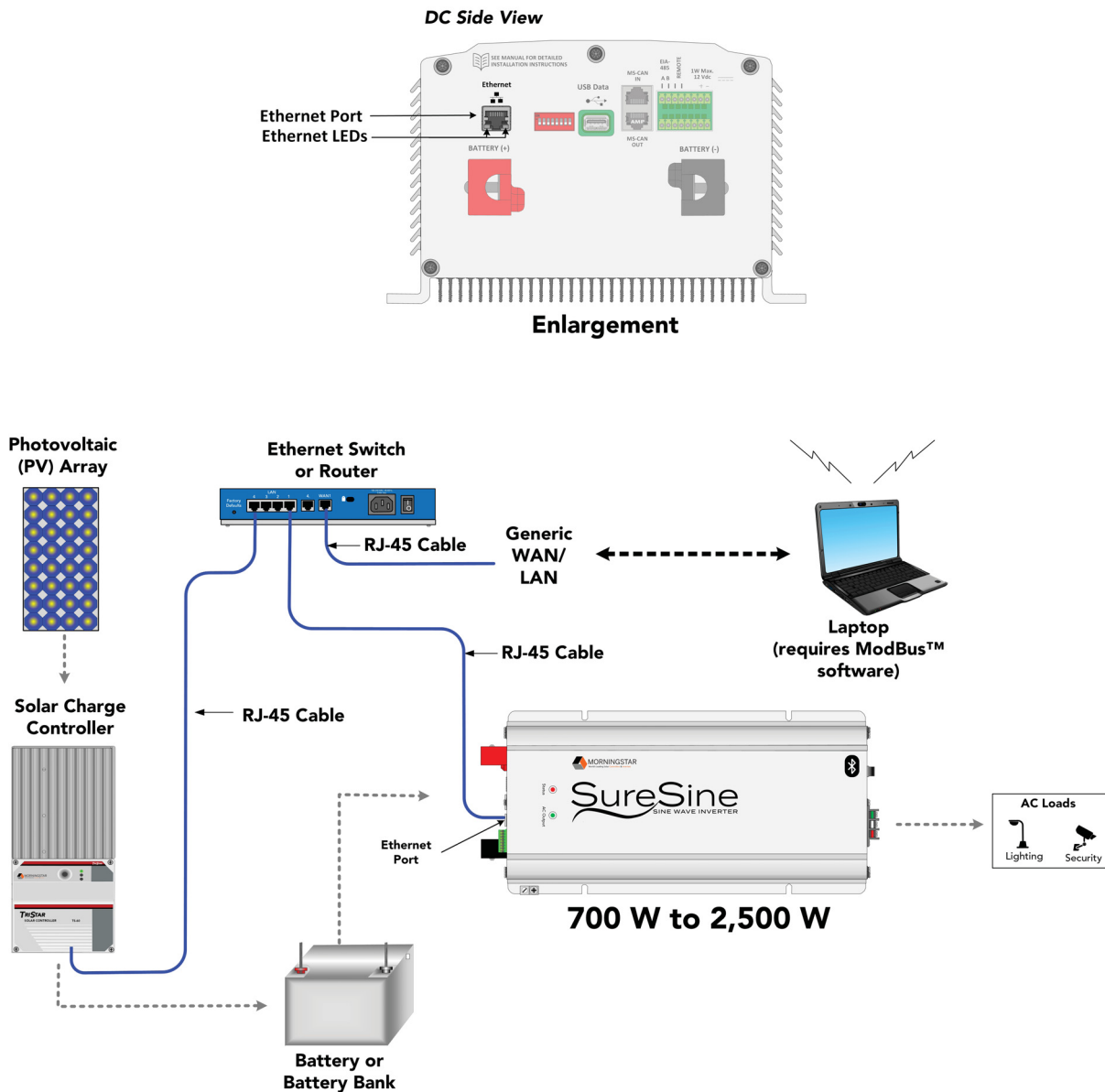

Figure 33: Communication using Ethernet

4.4 EIA-485 Device Communication

EIA-485 is a networking standard for serial communication between multiple devices on a bus. The EIA-485 port on the SureSine inverter is for connecting to one or more devices on an EIA-485 network through the open standard ModBus™ protocol.

Morningstar EIA-485 devices include the GenStar, TriStar-MPPT-60/M (150 and 600 V) models, or with other Morningstar products with the RSC-1 Serial-to-EIA-485 Adapter.

The TriStar-MPPT Charge Controller and RSC Serial adapters require an external 12 V power source to enable the EIA-485 communications. The 12 Vdc Auxiliary Power feature of 700 W to 2,500 W models can be used, therefore, to power Morningstar EIA-485 devices in an EIA-485 Network.



Figure 34: EIA-485/RS-232 Communications Adapter (RSC-1)

For more information on EIA-485 networking, refer to the Morningstar Product Connectivity Manual, Networking & Communications, at <https://www.morningstarcorp.com/wp-content/uploads/2014/02/MS-Comm-Document-2010.pdf>.

4.4.1 To Connect the SureSine Inverter to an EIA-485 Device

1. Connect the A and B wires from the EIA-485 device to the A and B terminals on the DC Side of the SureSine Inverter.
2. Connect the other ends of the A and B wires to the EIA-485 device.

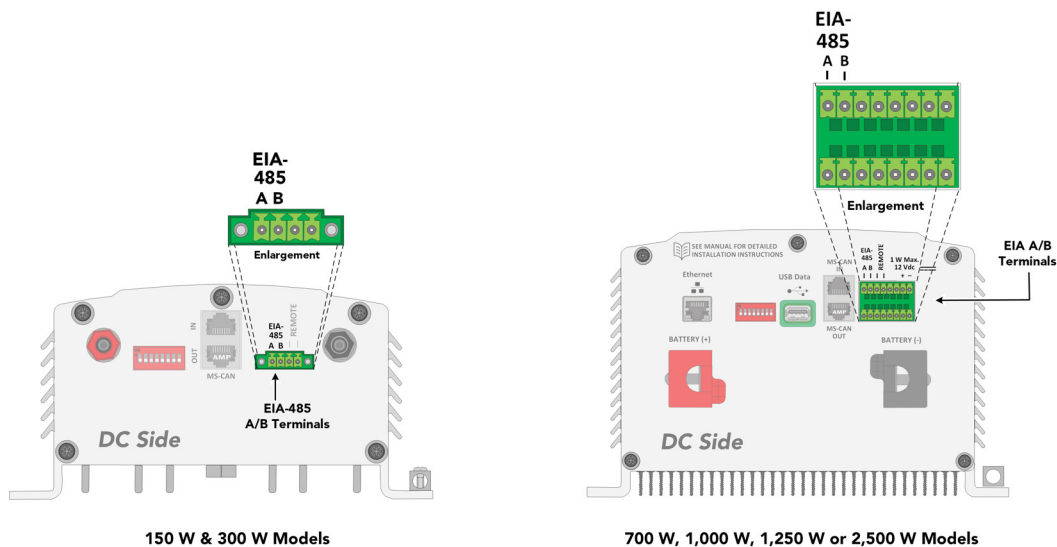

Figure 35: Connecting to an EIA-485 Device



3. If using the Auxiliary Power feature of a SureSine 700 W to 2,500 W model to power Morningstar EIA-485 devices in an EIA-485 Network:
 - connect the Ground (GND) terminal wire from the EIA-485 device(s) to the -12 V terminal of the SureSine inverter
 - connect the Power terminal wire from the EIA-485 device(s) to the (+12 V) terminal of the SureSine inverter.
 - The 12 V power supply is isolated. Therefore, the -12 V can be wired to the system ground regardless of whether there is a DC negative or positive ground.

Note: The 12 V Auxiliary Power rating is 1 Watt which will limit the number of EIA-485 devices that can be powered.

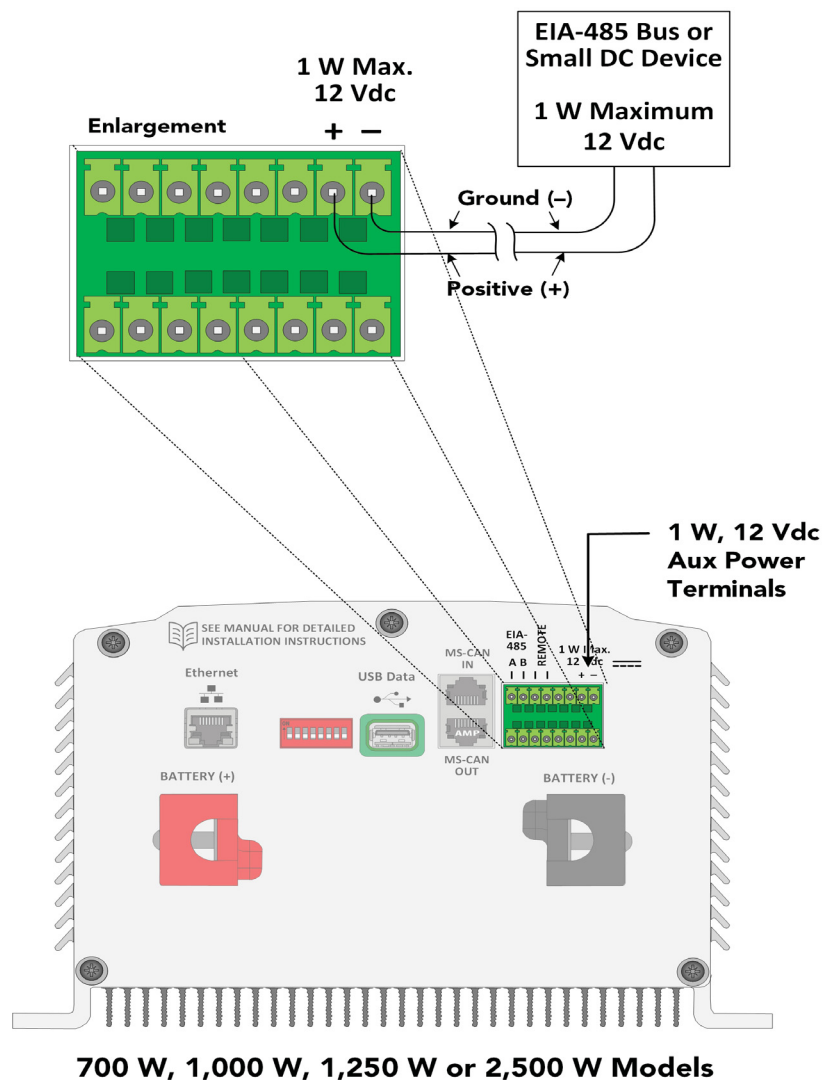

Figure 36: Auxiliary Power Connections (700 W, 1,000 W, 1,250 W or 2,500 W Models ONLY)

4.5 USB Port

A USB port is available on the 700 W, 1,000 W, 1,250 W, and 2,500 W models. The USB port can be used for ModBus™ communications. This port requires a USB-A plug. If connecting a computer, a USB-to-USB cable is required.

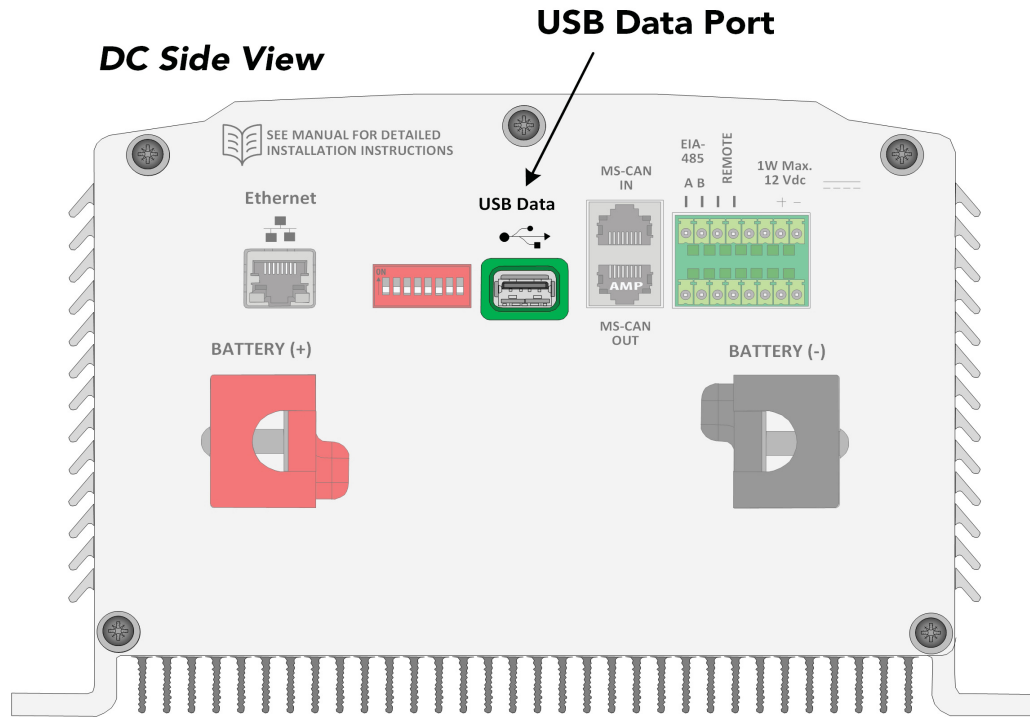

Figure 37: USB Port Locations

Note: USB-B and USB-C are backwards compatible with USB-A.

The factory default ModBus ID = 1.



4.6 MS-CAN (Future Feature)

MS-CAN is for communicating with other Morningstar components within the network. This feature is not available at this time. Check the Morningstar website (www.morningstarcorp.com) for updates. **Note:** The Morningstar component must be MS-CAN enabled.

4.6.1 To Connect the SureSine to another Morningstar Device

1. Insert one end of an RJ-45 cable (CAT5, CAT6, or CAT6e) into the **MS-CAN IN** port on the SureSine Inverter.
2. Insert a terminator resistor into the **MS-CAN OUT** port, if no other Morningstar devices are to be connected.
3. Connect the other end of the RJ-45 cable to the other Morningstar device.

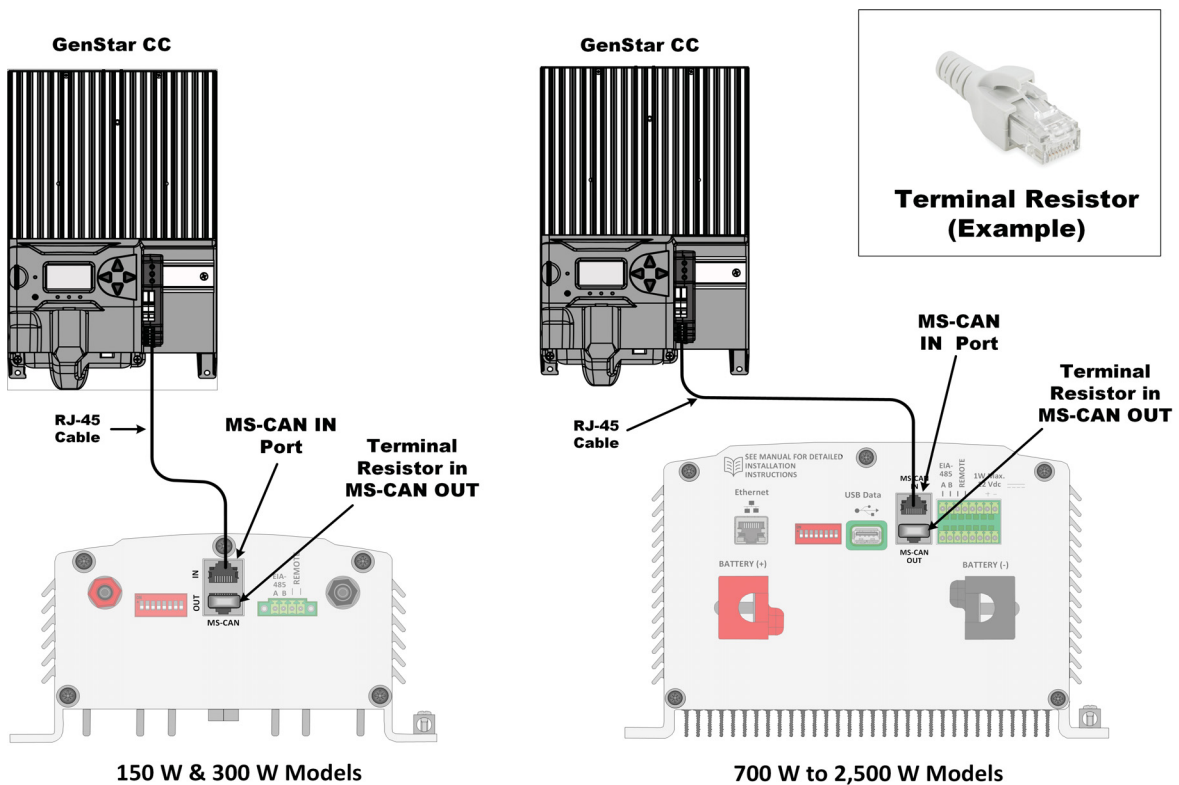

Examples only. Actual configuration may vary.

Figure 38: Communication Using MS-CAN

4.6.2 To Connect the SureSine to a Morningstar Network

1. Insert one end of an RJ-45 cable (CAT5, CAT6, or CAT6e) into the **MS-CAN OUT** port on the first device in the daisy chain.
2. Insert the other end of that RJ-45 cable into the **MS-CAN IN** port on the SureSine Inverter.
3. Insert another RJ-45 cable into the **MS-CAN OUT** port on the SureSine Inverter.
4. Insert the other end of the RJ-45 cable into the **MS-CAN IN** port on the next Morningstar device in the network.
5. Insert a 120 Ohm CANBUS terminator resistor into the **MS-CAN OUT** port on the final device, if no other Morningstar devices are to be connected.

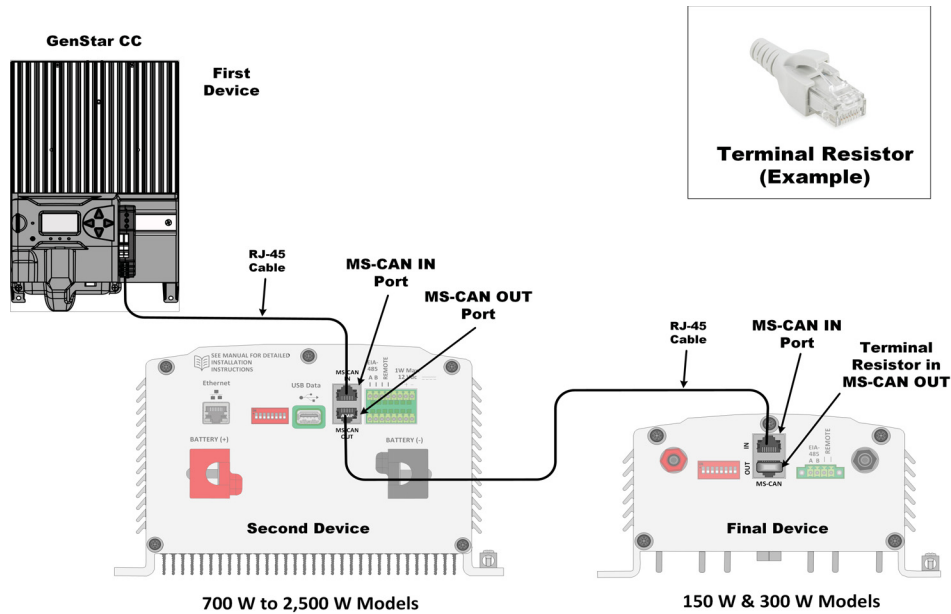

Example only. Actual configuration may vary.

Figure 39: Communication Using MS-CAN with Multiple Devices



5.0 FIRMWARE UPDATE PROCEDURE

To update the SureSine firmware, use the SureSine Utility Mobile App to activate the firmware update. The SureSine Mobile Utility App includes the latest version of the SureSine firmware when installing or updating the app.

Select the firmware update icon on the bottom right of the mobile app and follow the directions on the screen to update the firmware.

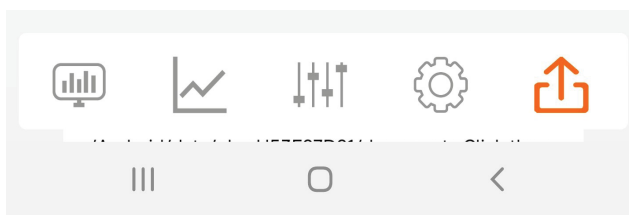

Figure 40: SureSine Mobile Utility App - Firmware Update Icon

6.0 INSPECTION AND MAINTENANCE

6.1 General Care

The SureSine should be mounted in a location out of direct sunlight with plenty of airflow for proper cooling. Prevent exposure to the elements and do not allow water to enter the inverter. Power connections must remain tight to avoid excessive heating from a loose connection.

	WARNING: SHOCK HAZARD
	Verify that all breakers are in the open/disconnected position, and that all fuses are removed from the holders before performing maintenance on the SureSine inverter.

6.2 Inspection Schedule

6.2.1 Two (2) Weeks After Installation

Re-tighten power terminal connections to specified torque values to avoid resistive connections.

6.2.2 Three (3) Months After Installation

Re-tighten power terminal connections to specified torque values to avoid resistive connections.

6.2.3 Annual Inspection

Perform the following tasks on an annual basis.

1. Re-tighten power terminal connections to specified torque values to avoid resistive connections.
2. Check all system fuses.
3. Inspect for broken wires, frayed wire insulation, and corroded conductors.
4. Inspect the system earth grounding for all components. Verify all grounding conductors are appropriately secured to earth ground.
5. Inspect for dirt, insects, nests. Clean if necessary.
6. Clean the heat sink fins with a clean, dry rag.
7. Check that the LED indicators match the system and inverter conditions at that time (see Section 3.1 "LED Indications" for details).
8. Open and close the Remote ON/OFF contacts (if used). Verify that the AC Output properly switches on and off.

6.3 Fuse Replacement

If the SureSine is unable to power on when DC power is connected, there is a possibility of a blown fuse caused by DC reverse polarity or over-current.



WARNING: SHOCK HAZARD

Disconnect all power sources to the inverter before removing the wiring box cover. Never remove the cover when voltage exists on the SureSine power connections.

To check the fuses:

1. Verify that all breakers are in the open/disconnected position, and that all fuses are removed from the holders.
2. Disconnect the positive Battery (+) connection from the battery.
3. Disconnect all wire connections to the SureSine.
4. Using a Philips screwdriver, remove the top three (3) screws of the DC and AC face plates to detach the cover plate from the inverter.
5. The two (2) or three (3) 40 A blade fuses are easy to identify and are inserted into blade fuse holders on the main circuit board near the DC terminals.



6. Remove and inspect each of the fuses.
 - Blown fuses will have a damaged filament.
7. Replace fuses as needed.
 - Replacement fuses must be quick-blow automotive type fuses only and should be rated for 40 A.
 - Commonly available automotive fuses rated for 32 V can be used with 12 V or 24 V models.
 - Fuses must be rated for 63 V or higher for all 48 V models.
8. Replace lid and secure with the six (6) screws after replacing fuses.
9. Reconnect wire connections per the installation instructions in Section 2.8.
10. Check Wiring and Power Up per the installation instructions in Section 2.9.

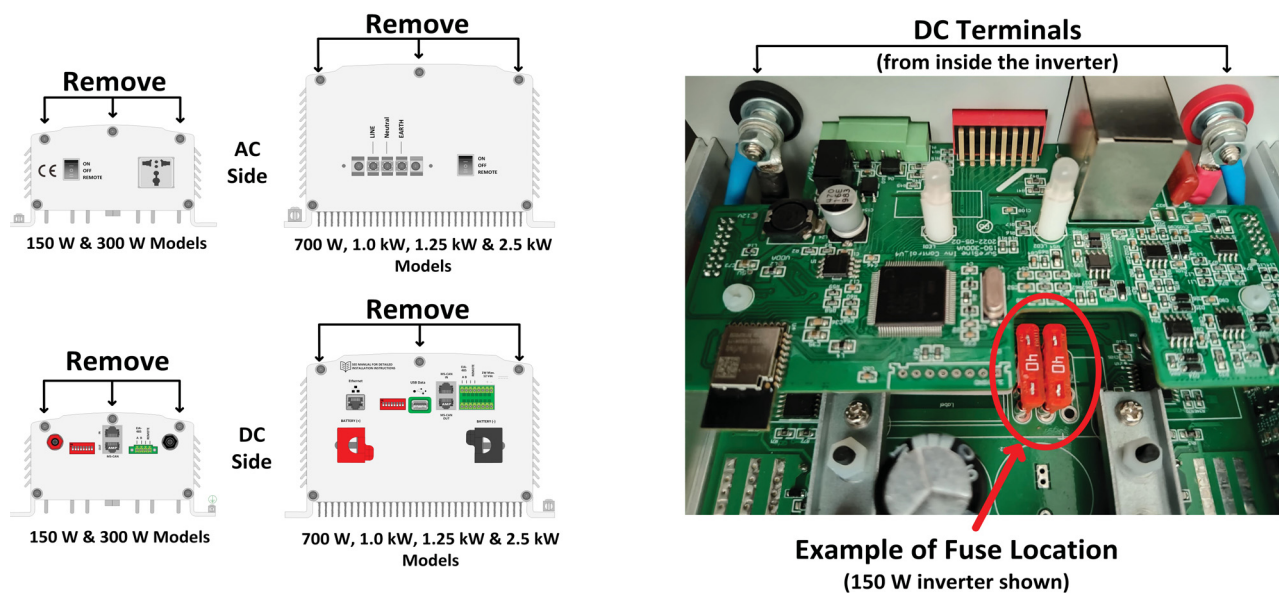

Figure 41: Replacing the Fuses

7.0 SPECIFICATIONS

7.1 SureSine Model Numbers

Figure 41 defines the SureSine Model numbers and how they relate to the product specifications.

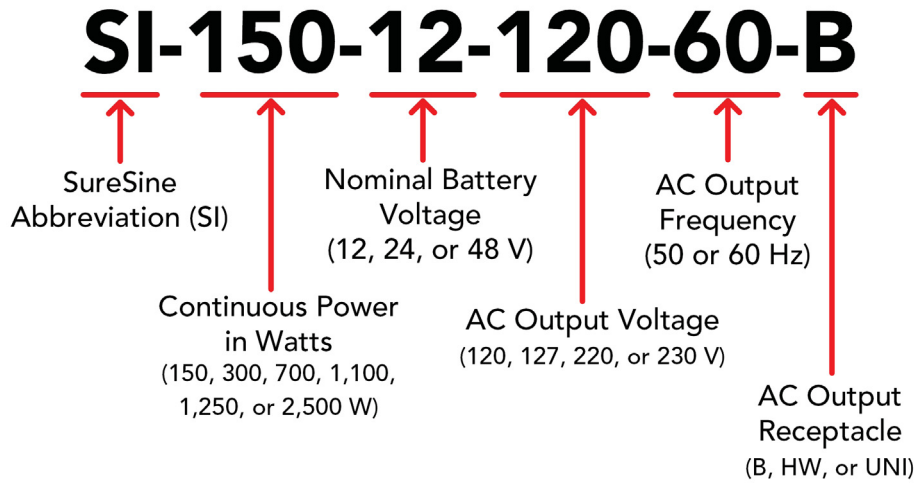

Figure 42: SureSine Product Key

Use Figure 42 to choose the SureSine model number from the list in Table 11.

- B = North American Type B
- HW = Hardwired
- UNI = Universal

Table 11: SureSine Model Numbers

Battery Voltage	Continuous Power in Watts					
	150 W	300 W	700 W	1,000 W	1,250 W	2,500 W
12 Vdc	SI-150-12-120-60-B	SI-300-12-120-60-B	SI-700-12-120-60-B			
	SI-150-12-120-60-HW	SI-300-12-120-60-HW	SI-700-12-120-60-HW			
	SI-150-12-127-60-HW	SI-300-12-127-60-HW				
	SI-150-12-127-60-UNI	SI-300-12-127-60-UNI				
	SI-150-12-220-60-HW	SI-300-12-220-60-HW				
	SI-150-12-220-60-UNI	SI-300-12-220-60-UNI				
	SI-150-12-230-50-HW	SI-300-12-230-50-HW	SI-700-12-230-50-HW			
	SI-150-12-230-50-UNI	SI-300-12-230-50-UNI	SI-700-12-230-50-UNI			

Table 11: SureSine Model Numbers

Battery Voltage	Continuous Power in Watts					
	150 W	300 W	700 W	1,000 W	1,250 W	2,500 W
24 Vdc	SI-150-24-120-60-B	SI-300-24-120-60-B	SI-700-24-120-60-B			
	SI-150-24-120-60-HW	SI-300-24-120-60-HW	SI-700-24-120-60-HW	SI-1000-24-120-60-HW	SI-1250-24-120-60-HW	
	SI-150-24-127-60-HW	SI-300-24-127-60-HW				
	SI-150-24-127-60-UNI	SI-300-24-127-60-UNI				
	SI-150-24-220-60-HW	SI-300-24-220-60-HW				
	SI-150-24-220-60-UNI	SI-300-24-220-60-UNI				
	SI-150-24-230-50-HW	SI-300-24-230-50-HW	SI-700-24-230-50-HW	SI-1000-24-230-50-HW	SI-1250-24-230-50-HW	
	SI-150-24-230-50-UNI	SI-300-24-230-50-UNI	SI-700-24-230-50-UNI			
48 Vdc	SI-150-48-120-60-B	SI-300-48-120-60-B	SI-700-48-120-60-B			
	SI-150-48-120-60-HW	SI-300-48-120-60-HW	SI-700-48-120-60-HW	SI-1000-48-120-60-HW	SI-1250-48-120-60-HW	SI-2500-48-120-60-HW
	SI-150-48-127-60-HW	SI-300-48-127-60-HW	SI-700-48-127-60-HW	SI-1000-48-127-60-HW	SI-1250-48-127-60-HW	SI-2500-48-127-60-HW
	SI-150-48-127-60-UNI	SI-300-48-127-60-UNI				
	SI-150-48-220-60-HW	SI-300-48-220-60-HW	SI-700-48-220-60-HW	SI-1000-48-220-60-HW	SI-1250-48-220-60-HW	SI-2500-48-220-60-HW
	SI-150-48-220-60-UNI	SI-300-48-220-60-UNI				
	SI-150-48-230-50-HW	SI-300-48-230-50-HW	SI-700-48-230-50-HW	SI-1000-48-230-50-HW	SI-1250-48-230-50-HW	SI-2500-48-230-50-HW
	SI-150-48-230-50-UNI	SI-300-48-230-50-UNI	SI-700-48-230-50-UNI			

7.2 Technical Specifications

The following tables provides the specifications for the SureSine Inverter Industrial Line.

Table 12: Specifications for the SureSine 150 and SureSine 300

Specification		Model					
		SureSine 150			SureSine 300		
Rated Battery Voltage		12 V	24 V	48 V	12 V	24 V	48 V
Battery Operational Voltage Range		10.0 to 16.5 V	20.0 to 33.0 V	40.0 to 66.0 V	10.0 to 16.5 V	20.0 to 33.0 V	40.0 to 66.0 V
Maximum Continuous DC Input Current		18 A	8 A	4 A	36.A	16 A	8 A
AC Output Voltage (Frequency) Options		120 V (60 Hz) / 230 V (50 Hz) / 127 V (60 Hz) / 220 V (60 Hz.)					
Maximum Continuous AC Output Current	120 V	1.25 A			2.5 A		
	230 V	0.65 A			1.3 A		
	127 V	1.7 A			2.4 A		
	220 V	0.7 A			1.4 A		
Continuous AC Output Power @ 40°C		150 W			300 W		
Power Surge @40°C (< 5 sec)		300 Watts			600 W		
1 minute Surge Power @ 40°C		225 Watts			450 W		
3 minute Surge Power @ 40°C		180 Watts			360 W		
Peak Efficiency		89%	89%	90%	91%	91%	92%
Total Harmonic Distortion (THD)		< 2%					
Self-Consumption	AC ON	2.6 W			3.9 W		
	AC OFF or Standby	0.65 W			0.65 W		
Standby ON/OFF Threshold		~ 8 W					
Transient Surge Protection		Battery and AC Loads					
Auxiliary Power		Not Available					
Remote Switch		Yes					
Product Weight (lbs. / kg)		9.6 lbs. / 4.4 kg			12.5 lbs. / 5.7 kg		
Shipping Weight		11 lbs. / 5.0 kg			13.5 lbs. / 6.2 kg		
Dimensions (L x W x H) (Factory-wired Models)		12.3" x 7.5" x 3.8" (312 mm x 190 mm x 96 mm)			13.1" x 7.5" x 3.8" (332 mm x 190 mm x 96 mm)		
Dimensions (L x W x H) (Hardwired Models)		12.6" x 7.5" x 3.8" (321 mm x 190 mm x 96 mm)			13.4" x 7.5" x 3.8" (340 mm x 190 mm x 96 mm)		
Mechanical:							
Battery Power Stud Bolt Size / Torque		M8 (~5/16"); 20 in-lbs. / 2.3 Nm; hand tighten					
AC Power Stud Size / Torque		M6 (~1/4"); 20 in-lbs. / 2.3 Nm					
Grounding Terminal wire size / Torque		14 - 2 AWG (2.5 - 10 mm ²); 35 in-lbs. / 4 Nm					
EIA-485/ Remote / Auxiliary plug-screw Block Terminals		16 to 28 AWG (1.0 to 0.1 mm ²); 5 in-lbs. / 0.57 nm					
AC Receptacle Options	120 V Models	N. A. NEMA 5, B-Type			N. A. NEMA 5, B-Type		
	230 V Models	Universal A-L Type			Universal A-L Type		

See Table 15 for Common Specifications for all Models.

Table 13: Specifications for the SureSine 700 and SureSine 1000

Specification	Model				
	SureSine 700			SureSine 1000	
Rated Battery Voltage	12 V	24 V	48 V	24 V	48 V
Battery Operational Voltage Range	10.0 to 16.5 V	20.0 to 33.0 V	40.0 to 66.0 V	20.0 to 33.0 V	40.0 to 66.0 V
Maximum Continuous DC Input Current	84 A	38 A	18.5 A	54 A	26.5 A
AC Output Voltage (Frequency) Options	120 V (60 Hz) / 230 V (50 Hz) / 127 V (60 Hz) / 220 V (60 Hz.)				
Maximum Continuous AC Output Current	120 V	5.8 A			8.3 A
	230 V	3.0 A			4.3 A
	127 V	5.5 A			8.0 A
	220 V	3.2 A			4.5 A
Continuous AC Output Power @ 40°C	700 W			1,000 W	
Power Surge @40°C (< 5 sec)	1,400 W			2,000 W	
1 minute Surge Power @40°C	1,050 W			1,500 W	
3 minute Surge Power @40°C	840 W			1,200 W	
Peak Efficiency	91%	92%	92%	93%	93%
Total Harmonic Distortion (THD)	2%				
Self-Consumption	AC ON	9.4 W			10.0 W
	AC OFF or Standby	< 2.8 W			< 2.3 W
Standby ON/OFF Threshold	~ 8 W				
Transient Surge Protection	Battery and AC Loads				
Auxiliary Power	12 V, 1 W				
Remote Switch	Yes				
Product Weight (lbs. / kg)	32.0 lbs. / 14.5 kg	30.0 lbs. / 13.5 kg		36.0 lbs. / 16.5 kg	
Shipping Weight	35.5 lbs. / 16.5 kg	33.5 lbs. / 15.5 kg		39.0 lbs. / 18.0 kg	
Dimensions (L x W x H) (Factory-wired Models)	12 V ONLY: 20.0" x 9.7" x 6.1" (508 mm x 247 mm x 156 mm)	24 V & 48 V: 17.6" x 9.7" x 6.1" (446 mm x 247 mm x 156 mm)		N/A	
Dimensions (L x W x H) (Hardwired Models)	12 V ONLY: 20.6" x 9.7" x 6.1" (523 mm x 247 mm x 156 mm)	24 V & 48 V: 18.2" x 9.7" x 6.1" (463 mm x 247 mm x 156 mm)		24 V & 48 V: 20.6" x 9.7" x 6.1" (523 mm x 247 mm x 156 mm)	
Mechanical:					
Battery Power Stud Bolt Size / Torque	M6 (~1/4"); 35 in-lbs. / 4 Nm				
AC Power Stud Size / Torque	M6 (~1/4"); 20 in-lbs. / 2.3 Nm				
Grounding Terminal wire size / Torque	14 - 2 AWG (2.5 - 10 mm ²); 35 in-lbs. / 4 Nm				
EIA-485/ Remote / Auxiliary plug-screw block Terminals	16 to 28 AWG (1.0 to 0.1 mm ²); 5 in-lbs. / 0.57 Nm				
AC Receptacle Options	120 V Models	N. A. NEMA 5, B-Type			Not Available
	230 V Models	Universal A-L Type			Not Available

See Table 15 for Common Specifications for all Models.

Table 14: Specifications for the SureSine 1250 and SureSine 2500

Specification	Model		
	SureSine 1250		SureSine 2500
Rated Battery Voltage	24 V	48 V	48 V
Battery Operational Voltage Range	20.0 to 33.0 V	40.0 to 66.0 V	40.0 to 66.0 V
Maximum Continuous DC Input Current	68 A	33 A	66 A
AC Output Voltage (Frequency) Options	120 V (60 Hz) / 230 V (50 Hz) / 127 V (60 Hz) / 220 V (60 Hz.)		
Maximum Continuous AC Output Current	120 V	10.4 A	21.0 A
	230 V	5.4 A	11.0 A
	127 V	10.0 A	20.0 A
	220 V	5.7 A	11.5 A
Continuous AC Output Power @ 40°C	1,200 W		2,500 W
Power Surge @40°C (< 5 sec)	2,500 W		5,000 W
1 minute Surge Power @40°C	1,875 W		3,750 W
3 minute Surge Power @40°C	1,500 W		3,000 W
Peak Efficiency	93%	94%	95%
Total Harmonic Distortion (THD)	2%		
Self-Consumption	AC ON	9.4 W	10.0 W
	AC OFF or Standby	< 2.8 W	< 2.3 W
Standby ON/OFF Threshold	~ 8 W		
Transient Surge Protection	Battery and AC Loads		
Auxiliary Power	12 V, 1 W		
Remote Switch	Yes		
Product Weight (lbs. / kg)	39.0 lbs. / 17.5 kg		59.0 lbs. / 27.0 kg
Shipping Weight	42.5 lbs. / 19.5 kg		63.0 lbs. / 28.5 kg
Dimensions (L x W x H) (Factory-wired Models)	N/A		N/A
Dimensions (L x W x H) (Hardwired Models)	20.6" x 9.7" x 6.1" (523 mm x 247 mm x 156 mm)		22.4" x 9.7" x 7.4" (570 mm x 247 mm x 190 mm)
Mechanical:			
Battery Power Stud Bolt Size / Torque	M6 (~1/4"); 35 in-lbs. / 4 Nm		
AC Power Stud Size / Torque	M6 (~1/4"); 20 in-lbs. / 2.3 Nm		
Grounding Terminal wire size / Torque	14 - 2 AWG (2.5 - 10 mm ²); 35 in-lbs. / 4 Nm		
EIA-485/ Remote / Auxiliary plug-screw block Terminals	16 to 28 AWG (1.0 to 0.1 mm ²); 5 in-lbs. / 0.57 Nm		
AC Receptacle Options	120 V Models	Not Available	Not Available
	230 V Models	Not Available	Not Available

See Table 15 for Common Specifications for all Models.



Table 15: Common Specifications for all Models

Features	Waveform - Pure Sine Wave
	Galvanically Isolated
	Cooling - Fanless natural convection
Electronic Protections	AC Output Short Circuit
	AC Output Overload
	High Heat Sink Temperature - Load Disconnect
	Battery Reverse Polarity - Replaceable internal fuse
	Heat Sink Temperature: Warning 90°C; Fault > 95°C; Recovery 80°C
Environmental	Storage Temperature Range: -40°C to +60°C
	Operating Temperature Range - 40°C to +60°C
	Humidity - 100% non-condensing
	Enclosure IP Rating: IP 20
	Altitude - 2,000 meters
Communications	MODBUS RS-485
	MS-CAN
	MODBUS over Ethernet (700 Watts and above only)
	USB (700 Watts and above only)
	Wireless Communications Bluetooth (Android and Apple)
	Data Storage 4 MB / 5 years internal 4 MB / 5 years internal
Warranty	5 Years

Table 16: Low Voltage Disconnect Settings

Low Voltage Disconnect Factory Default & Presets (All Models)	12-volt Models			24-volt Models			48-volt Models		
	LVD	LVR	Alarm	LVD	LVR	Alarm	LVD	LVR	Alarm
Factory Default Settings (DIP 4 OFF)*	11.8	12.8	12.1	23.6	25.6	24.2	47.2	51.2	48.4
Preset Low (DIP 4 ON, DIP 5 OFF)	10.5	11.6	10.8	21.0	23.2	21.6	42.0	46.4	43.2
Preset High (DIP 4 ON, DIP 5 ON) *	11.5	12.6	11.8	23.0	25.2	23.6	46.0	50.4	47.2

***Note:** DIP 4 in the OFF position allows the factory-default values to be changed using the RS485 communication port or Bluetooth App, if needed. When DIP 4 is in the OFF position, it disables DIP 5. So when DIP 4 is in the OFF position, the position of DIP 5 is irrelevant.

APPENDIX A: DC BATTERY WIRE SIZING

Wire sizing requirements are based on the ampacity (or current carrying capacity) of conductors. The NEC includes Ampacity Tables which are used to determine the ampacity for a given wire size as indicated in Section 310.15.

The battery wire ampacity must be greater than or equal to 125% of maximum continuous battery current of the SureSine inverter. If the inverter is not intended to be used to full capacity smaller wires can be used but only with an undersized breaker to ensure that the current will not exceed the current carrying capacity of the wire.

Correction and adjustment factors may be required to account for the following:

- maximum ambient temperature
- temperatures at different parts of the circuit (rooftops or engine rooms for example)
- wire terminal temperature ratings
- multi conductor cables
- conduit fill and other factors

The following tables provide the 1-way, maximum length for cables and wires based on the system voltage and ampacity with a 2% voltage drop.

Table 17: Minimum Battery Wire Sizes - 75°C Rated Stranded Copper

Model		Max Battery Continuous Current	Wire Size in a raceway, cable, or earth (NOTE: 1)		Wire Size in Free Air (NOTE 2)		Metric Wire Size mm ² (NOTE 3)
Watts	Volts		@30°C	30° - 60°C	@30°C	30°-45°C	
150 W	12 Vdc	18 Amps	10 AWG	8 AWG > 55°C	10 AWG	10 AWG	> 4 mm ²
150 W	24 Vdc	8 Amps	14 AWG	14 AWG	14 AWG	14 AWG	> 1.5 mm ²
150 W	48 Vdc	4 Amps	14 AWG	14 AWG	14 AWG	14 AWG	> 1.5 mm ²
300 W	12 Vdc	36 Amps	8 AWG	6 AWG > 35°C	8 AWG	6 AWG > 55°C	> 6 mm ²
300 W	24 Vdc	16 Amps	12 AWG	10 AWG	12 AWG	10 AWG	> 4 mm ²
300 W	48 Vdc	8 Amps	14 AWG	14 AWG	14 AWG	14 AWG	> 1.5 mm ²
700 W	12 Vdc	84 Amps	2 AWG	1 AWG > 30°C 1/0 AWG > 55°C	4 AWG	3 AWG > 40°C 2 AWG > 50°C	> 25 mm ²
700 W	24 Vdc	38 Amps	6 AWG	4 AWG > 50°C	8 AWG	6 AWG > 55°C	> 6 mm ²
700 W	48 Vdc	18.5 Amps	10 AWG	8 AWG > 55°C	10 AWG	10 AWG	> 4 mm ²
1,000 W	24 Vdc	54 Amps	4 AWG	3 AWG > 45°C	6 AWG	4 AWG > 50°C	> 16 mm ²
1,000 W	48 Vdc	26.5 Amps	8 AWG	6 AWG > 55°C	8 AWG	8 AWG	> 6 mm ²
1,250 W	24 Vdc	68 Amps	3 AWG	2 AWG > 40°C 1 AWG > 50°C	6 AWG	4 AWG > 40°C 3 AWG > 55°C	> 16 mm ²
1,250 W	48 Vdc	33 Amps	8 AWG	6 AWG > 40°C 4 AWG > 55°C	8 AWG	6 AWG > 55°C	> 10 mm ²

Note 1: Per NEC 2023 [see NEC Table 310.16, formerly 310.15(b)(16)], ampacity for not more than three current-carrying conductors in a raceway, cable, or earth (buried)

Note 2: Per NEC 2023 [see NEC Table 310.17, formerly 310.15(b)(17)], ampacity for conductors in free air

Note 3: Estimated. See local code requirements for metric cable sizing (70°C or 90°C)



Table 17: Minimum Battery Wire Sizes - 75°C Rated Stranded Copper

Model		Max Battery Continuous Current	Wire Size in a raceway, cable, or earth (NOTE: 1)		Wire Size in Free Air (NOTE 2)		Metric Wire Size mm ² (NOTE 3)
Watts	Volts		@30°C	30° - 60°C	@30°C	30°-45°C	
2,500 W	48 Vdc	66 Amps	3 AWG	2 AWG > 40°C 1 AWG > 50°C	6 AWG	4 AWG > 55°C	> 16 mm ²

Note 1: Per NEC 2023 [see NEC Table 310.16, formerly 310.15(b)(16)], ampacity for not more than three current-carrying conductors in a raceway, cable, or earth (buried)

Note 2: Per NEC 2023 [see NEC Table 310.17, formerly 310.15(b)(17)], ampacity for conductors in free air

Note 3: Estimated. See local code requirements for metric cable sizing (70°C or 90°C)

Table 18: Minimum Battery Wire Sizes - 90°C Rated Stranded Copper

Model		Max Battery Continuous Current	Wire Size in a raceway, cable, or earth (NOTE: 1)		Wire Size in Free Air (NOTE 2)	
Watts	Volts		@30°C	30° - 60°C	@30°C	30°-45°C
150 W	12 Vdc	18 Amps	10 AWG	10 AWG	10 AWG	10 AWG
150 W	24 Vdc	8 Amps	16 AWG	16 AWG	14 AWG	16 AWG
150 W	48 Vdc	4 Amps	16 AWG	16 AWG	14 AWG	16 AWG
300 W	12 Vdc	36 Amps	8 AWG	6 AWG > 45°C	8 AWG	8 AWG
300 W	24 Vdc	16 Amps	12 AWG	10 AWG > 55°C	12 AWG	12 AWG
300 W	48 Vdc	8 Amps	16 AWG	16 AWG	14 AWG	16 AWG
700 W	12 Vdc	84 Amps	3 AWG	2 AWG > 35°C 1 AWG > 45°C	4 AWG	3 AWG > 50°C
700 W	24 Vdc	38 Amps	8 AWG	6 AWG > 40°C 4 AWG > 55°C	8 AWG	8 AWG
700 W	48 Vdc	18.5 Amps	10 AWG	10 AWG	10 AWG	10 AWG
1,000 W	24 Vdc	54 Amps	6 AWG	4 AWG > 35°C 3 AWG > 45°C	6 AWG	4 AWG > 50°C
1,000 W	48 Vdc	26.5 Amps	8 AWG	6 AWG > 55°C	8 AWG	8 AWG
1,250 W	24 Vdc	68 Amps	4 AWG	3 AWG > 40°C 2 AWG > 50°C	6 AWG	4 AWG > 40°C 3 AWG > 55°C
1,250 W	48 Vdc	33 Amps	8 AWG	6 AWG > 50°C	8 AWG	6 AWG > 55°C
2,500 W	48 Vdc	66 Amps	4 AWG	3 AWG > 40°C 2 AWG > 50°C	6 AWG	4 AWG > 55°C

Note 1: Per NEC 2023 [see NEC Table 310.16, formerly 310.15(b)(16)], ampacity for not more than three current-carrying conductors in a raceway, cable, or earth (buried)

Note 2: Per NEC 2023 [see NEC Table 310.17, formerly 310.15(b)(17)], ampacity for conductors in free air



Table 19: Celsius-to-Fahrenheit Conversions

°Celsius	°Fahrenheit
30	86
35	95
40	104
45	113
50	122
55	131
60	140



APPENDIX B: DC VOLTAGE DROP TABLES

Good system design generally requires large conductor wires that limit voltage drop losses to 2% or less. Table 20 and Table 21 provide wire sizing for a maximum of 2% voltage drop. Longer distance wire runs may require significantly larger wire sizes to reduce the voltage drop to an acceptable level.

B.1 Voltage Drop Chart for 75°C or 90°C Stranded Copper Wire (Feet), 12 Volt System

For 24- or 48-volt systems, multiply the values in Table 20 by:

- 2 for 24-volt systems
- 4 for 48-volt systems

Table 20: Maximum 1-way Distance (Feet), 2% Voltage Drop Chart for 75°C or 90°C Stranded Copper Wire, 12-Volt System

Wire Size (AWG)	Amps														
	70	60	55	50	45	40	35	30	25	20	15	12	10	8	5
4/0	31.3	36.5	39.8	43.8	48.6	54.7	62.5	72.9	87.5						
3/0	24.8	28.9	31.6	34.7	38.6	43.4	49.6	57.9	69.5	86.8					
2/0	19.6	22.9	25.0	27.5	30.6	34.4	39.3	45.8	55.0	68.8	91.7				
1/0	15.6	18.2	19.8	21.8	24.2	27.3	31.1	36.3	43.6	54.5	72.7	90.8			
1	12.3	14.4	15.7	17.3	19.2	21.6	24.7	28.8	34.5	43.2	57.6	72.0	86.4		
2	9.8	11.4	12.5	13.7	15.2	17.1	19.6	22.9	27.4	34.3	45.7	57.1	68.6	85.7	
3	7.8	9.0	9.9	10.9	12.1	13.6	15.5	18.1	21.7	27.1	36.2	45.2	54.3	67.9	
4	6.2	7.2	7.9	8.6	9.6	10.8	12.3	14.4	17.3	21.6	28.8	36.0	43.2	54.0	86.4
6		4.5	4.9	5.4	6.0	6.8	7.7	9.0	10.8	13.5	18.1	22.6	27.1	33.9	54.2
8				3.4	3.8	4.3	4.9	5.7	6.8	8.5	11.4	14.2	17.1	21.4	34.2
10							3.1	3.6	4.3	5.4	7.2	8.9	10.7	13.4	21.5
12									2.7	3.4	4.5	5.6	6.7	8.4	13.4
14										2.1	2.8	3.5	4.2	5.3	8.5
16												2.2	2.7	3.3	5.3

B.2 Voltage Drop Chart for 75°C or 90°C Stranded Copper Wire (Meters), 12 Volt System

For 24- or 48-volt systems, multiply the values in Table 21 by:

- 2 for 24-volt systems
- 4 for 48-volt systems

Table 21: Maximum 1-way Distance (Meters), 2% Voltage Drop Chart for 75°C or 90°C Stranded Copper Wire, 12-Volt System

Wire Size (mm ²)	Amps														
	70	60	55	50	45	40	35	30	25	20	15	12	10	8	5
95	8.0	9.3	10.2	11.2	12.5	14.0	16.0	18.7	22.4	28.0					
70	5.8	6.8	7.4	8.1	9.0	10.2	11.6	13.6	16.3	20.3	27.1				
50	4.0	4.7	5.1	5.6	6.3	7.0	8.0	9.4	11.3	14.1	18.8	23.5	28.2		
35	3.0	3.5	3.8	4.2	4.6	5.2	6.0	6.9	8.3	10.4	13.9	17.4	20.8	26.0	
25	2.1	2.5	2.7	3.0	3.3	3.8	4.3	5.0	6.0	7.5	10.0	12.5	15.0	18.8	30.0
16	1.4	1.6	1.7	1.9	2.1	2.4	2.7	3.2	3.8	4.8	6.3	7.9	9.5	11.9	19.0
10		1.0	1.1	1.2	1.3	1.5	1.7	2.0	2.4	3.0	4.0	5.0	6.0	7.5	11.9
6				0.7	0.8	0.9	1.0	1.2	1.4	1.8	2.4	3.0	3.6	4.4	7.1
4						0.6	0.7	0.8	0.9	1.2	1.6	2.0	2.4	3.0	4.7
2.5								0.5	0.6	0.7	1.0	1.2	1.5	1.8	2.9
1.5												0.6	0.7	0.9	1.6

APPENDIX C: WARRANTY

The SureSine™ inverters are warrantied to be free from defects in materials and workmanship for a period of FIVE (5) years from the date of shipment to the original end user. Warranty on replaced units or field-replaced components, will be limited only to the duration of the original product coverage.

Morningstar will, at its option, repair or replace any such defective unit.

C.1 Claim Procedure

Before requesting warranty service, check the operator's manual, including any troubleshooting section, to verify product failure.

To begin the warranty replacement process, contact your authorized Morningstar distributor or dealer for assistance with troubleshooting and, if necessary, obtaining an Return Material Authorization (RMA) number.

An RMA number must be issued by Morningstar prior to return of any unit(s) under this warranty. Required RMA information:

- (A) purchase location - business or company name - and date
- (B) full model and serial numbers (SN is 8-digits on unit bar label)
- (C) failure behavior, including LED indications
- (D) array configuration, panel Pmax, Voc, Vmp, Isc, and nominal battery voltage; these specifications are needed to receive assistance.
- (E) multi-meter available (for field troubleshooting)

If the dealer is contacted, and is not able to assist with warranty claim, contact Morningstar Tech support at support@morningstarcorp.com. Provide proof of date and place of purchase, and all details listed in preceding paragraph.

C.2 Warranty Exclusions And Limitations

This warranty does not apply under the following conditions:

- Damage by accident, negligence, abuse or improper use
- PV or load currents exceeding the ratings of the product
- Unauthorized product modification or attempted repair
- Damage occurring during shipment
- Damage resulting from acts of nature such as lightning, weather extremes, or infestation

THE WARRANTY AND REMEDIES SET FORTH ABOVE ARE EXCLUSIVE AND IN LIEU OF ALL OTHERS, EXPRESS OR IMPLIED. MORNINGSTAR SPECIFICALLY DISCLAIMS ANY AND ALL IMPLIED WARRANTIES, INCLUDING, WITHOUT LIMITATION, WARRANTIES OF MERCHANTABILITY AND FITNESS FOR A PARTICULAR PURPOSE. No Morningstar distributor, agent or employee is authorized to make any modification or extension to this warranty.

MORNINGSTAR IS NOT RESPONSIBLE FOR INCIDENTAL OR CONSEQUENTIAL DAMAGES OF ANY KIND, INCLUDING BUT NOT LIMITED TO LOST PROFITS, DOWN-TIME, GOODWILL OR DAMAGE TO EQUIPMENT OR PROPERTY.



APPENDIX D: REVISION HISTORY

Date	Reason for Revision	Revision
October 2022	Original Publication	0
December 2022	<p>Modified a Wire and Cable Safety WARNING: SHOCK HAZARD involving the Neutral-ground Bond. Added 3rd bullet.</p> <p>Replaced Section 2.8.4, Grounding and Bonding Requirements, with revised text.</p> <p>Revised Table 9 to modify the System Fault indications.</p>	1
April 2023	<p>MOUNTING, CLEARANCE AND LOCATION SAFETY: Revised CAUTION to remove "...by anyone or anything."</p> <p>CERTIFICATIONS: Updated listings.</p> <p>Global Change: Changed "SureSine Utility App" to "Sure Sign Utility Mobile App".</p> <p>Section 2.2, Additional Hardware Requirements. Revised bullet for AC Wiring to remove model specificity.</p> <p>Section 2.3.1:</p> <ul style="list-style-type: none"> • CAUTION: Equipment Damage. Modified first bullet regarding zero-clearance. • CAUTION: HOT SURFACE/BURN HAZARD. Revised to remove "by anyone". <p>Section 1.5, Figure 5. Updated the dimension values.</p> <p>Section 1.6, Figure 6. Updated the dimension values.</p> <p>Section 2.4.1, Figure 11. Revised illustration to modify DIP #1.</p> <p>Section 2.4.2, Table 1. Updated DIP #1 Function definition and Note.</p> <p>Section 2.8.2, WARNING: Risk of Fire. Revised first sentence.</p> <p>Figure 17. Modified the Illustration to remove the connection between the DC Earth Ground and the AC Neutral-Ground Bond.</p> <p>Section 2.9, Check Wiring and Power Up. Modified Step 5.</p> <p>Global Change: Changed Modbus and Modbus TCP/IP to ModBus™ and ModBus TCP/IP™</p> <p>Section 4. Communication Options. Revised the list of communication options.</p> <p>Section 4.2.2, SureSine Utility App. Revised the section.</p> <p>Section 4.3, Ethernet (for ModBus TCP/IP™. Revised the section.</p> <p>Section 4.3.1. Revised the heading title, steps to connect the inverter to the Internet, and Figure 33.</p> <p>Section 4.4. EIA-485 Device Communications. Revised the section.</p> <p>Section 4.5.USB Port. Revised the section.</p> <p>Section 5.0 Firmware Update Procedure. Revised the section. Added new Figure.</p> <p>Section 6. Specifications.</p> <ul style="list-style-type: none"> • Added Product Key Illustration and table. • Revised specifications for weight, shipping weight, and dimensions. Added dimensions for the hardwired models. 	2



Date	Reason for Revision	Revision
October 2023	<p>Certifications Page: Added the following " Complies with UL 458:2015 Ed.6+R:11 Jan2021"</p> <p>Revised Figure 1:</p> <ul style="list-style-type: none"> • Change text "700 W Models" to "700 W (24 V & 48 V) Models" • Change text "1,000 W and 1,250 W Models" to "700 W (12 V), 1,000 W & 1,250 W Models" <p>Revised Figure 5:</p> <ul style="list-style-type: none"> • Hard-Wired Versions <ul style="list-style-type: none"> – 300 W Models 13.4" • Factory-Wired Versions <ul style="list-style-type: none"> – 300 W Models 13.1 (332 mm) <p>Revised Figure 6:</p> <ul style="list-style-type: none"> • Factory-Wired Versions <ul style="list-style-type: none"> – 700 W (12 V) Models: 20.0" (508 mm) – 700 W (24 V & 48 V) Models: 17.6" (446 mm) • Hard-Wired Versions <ul style="list-style-type: none"> – 700 W (12 V) Models: 20.6" (523 mm) – 700 W (24 V & 48 V) Models: 18.2" (463 mm) • Revised Height dimension for 2,500 W model to 6.1" (156 mm) <p>Added Section 3.4.5 Reverse Polarity Protection</p> <p>Revised Section 4.2.2 SureSine Mobile Utility App</p> <ul style="list-style-type: none"> • Removed "(coming soon)" • Modified "will be" to "is" • Added hyperlinks • Added sentence with password below Figure 32. <p>Section 4.4.1, Step 3: Added new 3rd bullet</p> <ul style="list-style-type: none"> • (NEW) The 12 V power supply is isolated. Therefore, the –12 V can be wired to the system ground regardless of whether there is a DC negative or positive ground. <p>Added new Section 6.0 Inspection and Maintenance.</p> <ul style="list-style-type: none"> • Added a new Figure 41. <p>Revised Tables 12, 13 & 14 to include the specification for Standby ON/OFF Threshold and to update dimensions as revised in Figures 5 and 6.</p>	3

Index

A

- AC circuit breaker/fuse ratings 30
- AC Connections 29
- AC neutral ground bond 30
- AC Neutral-Ground Bond..... 20
- AC Output LED 32
- AC Output Mode Switch 32, 33
 - Operation..... 33
- AC Output Wire Size 19
- AC Over-current Protection Device Sizing 18
- AC Wiring 30, 31
- Annual Inspection..... 48
- Auxiliary Power 15

B

- Batteries 7
- Battery Bank 7
- Battery Over-current Protection Device Sizing 17
- Battery Status 1
- Battery Systems 25
- Battery Types..... 1, 7
- Battery Voltage..... 7
- Battery Wire Sizing 56
- Bluetooth..... 1, 36
- Bluetooth Activation..... 33

C

- Chassis Ground 24
- Communication Options 1, 36
 - Bluetooth 38
 - EIA-485 Device 42
 - Modbus..... 40
 - MS-CAN..... 45
 - USB Port..... 44
- Components
 - 150 W & 300 W Models..... 2
 - 700 W to 2,500 W Models..... 3, 4
- Critical Fault..... 35

D

- DC Connections 25
 - 150 W & 300 W Models
 - Negative Grounding 27
 - Positive Grounding 27
 - 700 W to 2,500 W Models
 - Negative Grounding 28
 - Positive Grounding 28

- DC System Ground..... 24
- DC Voltage Drop 59
- DC Voltage Requirements 7
- DC Wiring..... 26
- Dimensions
 - 150 W & 300 W Models..... 5, 53
 - 700 W to 2,500 W Models 6, 54
- DIP Switch 1
 - Configuration Options 12
 - Location 11

E

- EIA-485..... 1, 36
- Electronic Protections..... 1
- Ethernet..... 1, 41
- Ethernet LED Indicators 33
- Ethernet Security 37

F

- fault..... 29
- Fault Recovery 1
- Firmware Update..... 47
- Fuse Replacement..... 48, 49

G

- GFDI 29
- Ground Connections 23
 - Chassis Ground..... 24
 - DC System Ground 24
 - Negative Grounding 26
 - Positive Grounding 26
- Grounding and Bonding 20
- Ground Wire, Minimum Size 24

H

- Hardware, Additional..... 7
- High Temperature Disconnect..... 34
- High Voltage Disconnect..... 34

I

- Inspection 47
- Inspection Schedule 47

L

- LED Indications..... 32
- LEDs 1, 32, 33
- Low Voltage Disconnect..... 34, 55

M

Maintenance.....	47
Modbus ID.....	41
Model numbers	50
Mounting.....	8
Orientation.....	8
MS-CAN	1, 36, 45

N

Negative Grounding.....	26
Neutral-Ground Bond.....	20, 24
External.....	20
Internal.....	20
Jumper.....	22

O

Output Mode	33
Output Voltages	1
Over Current Fault.....	35
Over-current Protection Sizing	17

P

Positive Grounding.....	26
Power Up.....	32

R

Remote Switch.....	7
Remote Switch Installation	14
Reverse Polarity	35
RSC-1 Serial-to-EIA-485 Adapter	42

S

Safety Definitions	
Cautions.....	C
Notes	C
Warnings.....	C
Safety Information	C
Settings.....	11
Short Circuit Protection	35
Specifications	
1,250 and 2,500 W.....	54
150 W & 300 W.....	50
700 W & 1,000 W Models.....	53
Common	55
Status LED	32
Stranded Copper Wire	59, 60
SureSine Utility App.....	38, 39
surge.....	29

T

Terminal Torque.....	16
Tools Required.....	7

U

USB Port	44
----------------	----

V

Voltage Drop	59, 60
--------------------	--------

W

Warranty	61
Claim Procedure	61
Exclusions And Limitations	61
RMA	61
Wire Sizing Requirements	30



MORNINGSTAR

World's Leading Solar **Controllers & Inverters**