



Tamarack Ground Mount Kit

Installation Manual

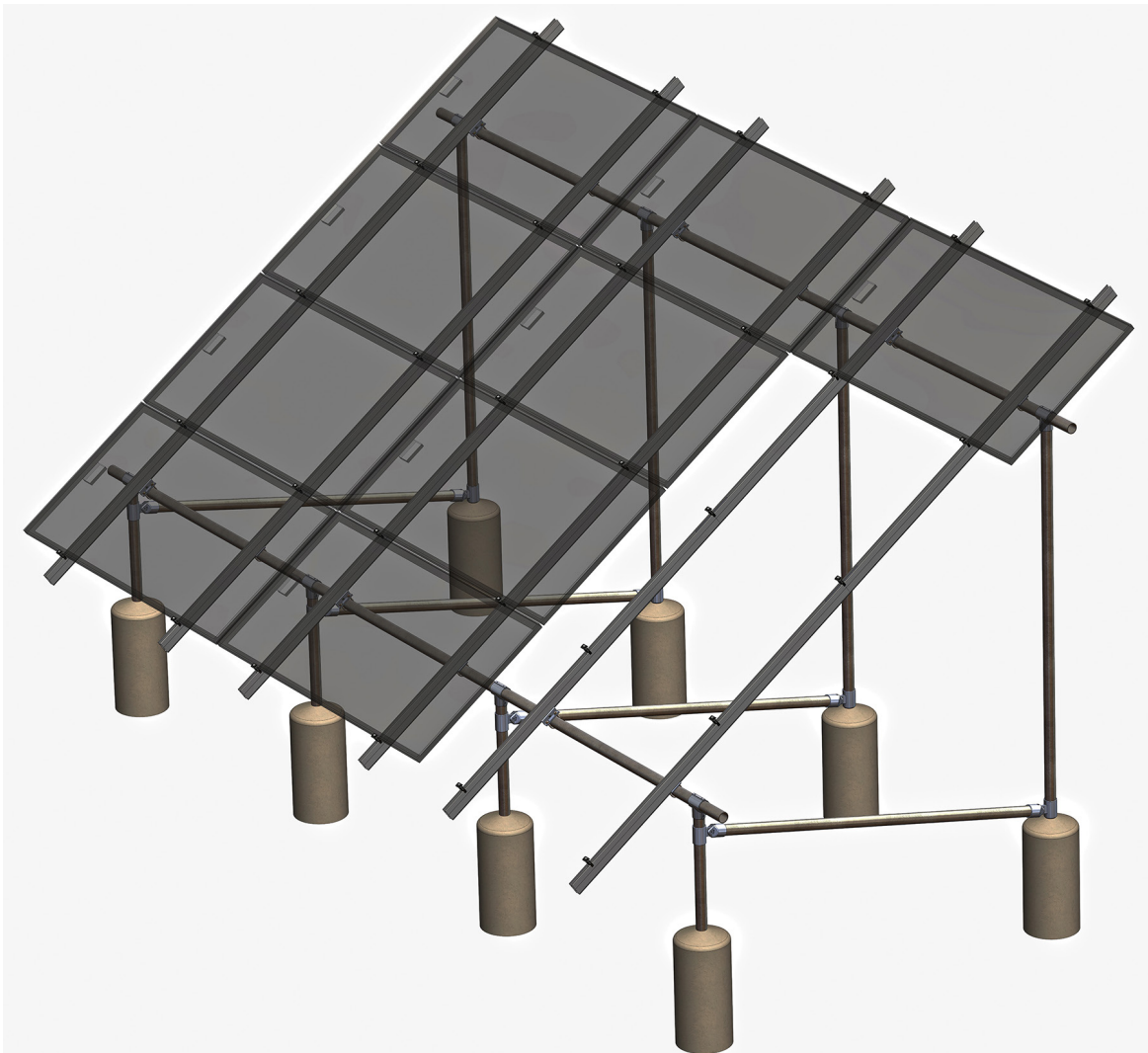

Table of Contents

Features and Ratings 3

Installer Responsibilities 4

System Components 5

Tools Required - Torque Specifications - Components List 6

System Design and Installation Preparation 7

Online Tool 8

Foundation Design and Construction 9 - 13

Attaching Rails 14

System Grounding 15

Module Level Power Electronics (MLPE) Installation & Wire Management . . . 16

Module Installation. 16 - 17

Module Compatability 18 - 19

Limited Warranty 20

Customer Support

Tamarack Solar makes every effort to ensure your mounting kit is easy to install. If you need assistance at any point in your installation or have suggestions on how we can improve your experience, call customer support at 1-800-819-7236 ext 556 or email us at support@tamaracksolar.com

Technical Support: 707-234-8107 or email us at support@tamaracksolar.com

Tamarack Ground Mount System Features

- Designed for mounting photovoltaic (PV) arrays on the ground.
- Top clamps and rail attachments require the use of a single standard 1/2-inch socket
- 5050 Clamp for both mid-clamp and end-clamp use simplifies ordering and stocking parts.
- Module clamps are spring loaded to ease module placement.
- Built-in wire management for module and microinverter cables.

Tamarack Product Summary

The Tamarack Solar Ground Mount system is a visually appealing photovoltaic (PV) module installation system that significantly lowers PV module installation cost by allowing the installation professional to stock fewer parts and to complete the installation in less time.

Certified to meet local and International Building Codes and ASCE/SEI-7 when installed in accordance with this manual.

ETL Listed to UL 2307 for bonding and grounding when installed in accordance with this manual.

Rails, clamps, splices, and mounting devices are UL2703 Listed for mounting flat-plate Photovoltaic Modules and Panels



- Conforms to STD UL 2703 (2015) Standard for Safety First Edition: Mounting Systems, Mounting Devices, Clamping/Retention Devices, and Ground Lugs for Use with Flat-Plate Photovoltaic Modules and Panels.
- Certified to CSA STD LTR AE-001-2012 Photovoltaic Module Racking Systems.
- Max Overcurrent Protective Device (OCPD) Rating: 20A
- Max Module Size: 30 sq-ft²
- System Level Allowable Design Load Rating: meets minimum requirements of the standard (10 PSF downward, 5 PSF upward, 5 PSF lateral). Actual system structural capacity is defined by PE stamped certification letters.

Tamarack Solar Ground Mounts use Hollaender® structural aluminum pipe fittings that combined with pipe make stable, secure, corrosion-free mounting rack systems for both ground and roof mounted solar arrays. Hollaender's Speed-Rail® fittings are ideal for this application because the aluminum-magnesium 535 alloy used to manufacture them is the most corrosion resistant aluminum alloy available. They can be used with steel without any concern for galvanic corrosion. Hollaender Speed-Rail® fittings are now approved as UL 2703 Recognized Components under ETL Mark 5006568. The system uses set-screws that penetrate the surface of the pipe to ensure that fittings are electrically bonded to pipe and bracing, thereby eliminating the need for added bonding components such as jumpers to provide a grounding path.

Disclaimer

This manual describes proper installation procedures and provides necessary standards required for product reliability. Warranty details are available on our website. www.tamaracksolar.com

All installers must thoroughly read this manual and have a clear understanding of the installation procedures prior to installation. Failure to follow these guidelines may result in property damage, bodily injury or even death.

Installer Responsibilities

- Follow all applicable local or national building and fire codes, including any that may supersede this manual.
- Electrical installation should be conducted by a licensed and bonded electrician or solar contractor.
- Module maintenance or removal must not break the bonding path of the system.
- Ensure all products used are appropriate for the installation and array under the site's wind and snow loading conditions.
- Ensure information used for the system design is accurate. Any inaccurate information used for the system design will cause errors and are the installer's responsibility to correct.
- We recommend consulting with your local building department about local regulations and building requirements, including soil conditions, terrain, and wind and snow load requirements. Local conditions and
- Use only Tamarack Solar Products parts or parts approved by Tamarack; substituting parts may void any applicable warranty.
- Ensure bare copper grounding conductors do not contact aluminum and zinc-plated steel components in order to prevent the risk of galvanic corrosion.
- The Installation should be inspected periodically, and any loose components or fasteners should be retightened. Any corroded parts found should be examined carefully to assess whether the corrosion compromises the physical integrity or performance of the system, and if so, the corrosion should be remediated, or the affected components replaced.
- Provide an appropriate method of direct-to-earth grounding according to the latest edition of the National Electrical Code, including NEC 250: Grounding and Bonding, NEC 690: Solar Photovoltaic Systems, and CSA C22.1, Safety Standard for Electrical Installations, Canadian Electrical Code, Part 1
- Disconnect AC power before servicing or removing microinverters and power optimizers.
- Review photovoltaic module manufacturer's documentation to ensure compatibility and compliance with warranty terms and conditions.
- Maximum Series Fuse Rating for the photovoltaic array is 20 Amps.

For Technical Support, call 707-234-8107 or 800-819-7236 ext.556 or email us at support@tamarack-solar.com.

Ground Mount Kit Description

- **Kits contains all parts required except 2-inch schedule 40 pipe and concrete**
- **Rated for up to 170 MPH wind speed and 70 psf of snow load**
- **Some situations require cross bracing (see online tool info on page 8)**

Tamarack Ground Mount Kit Components



3.1 inch Rail

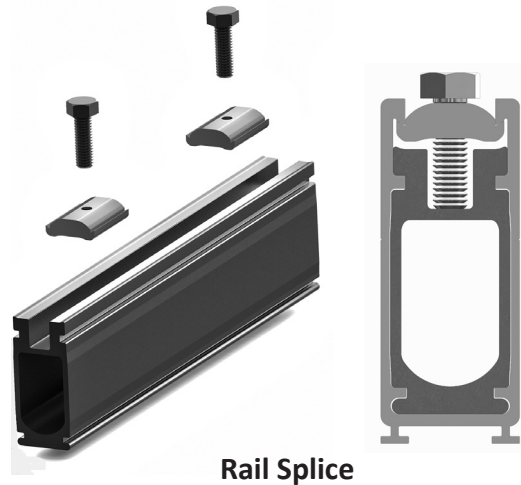

Rail Splice

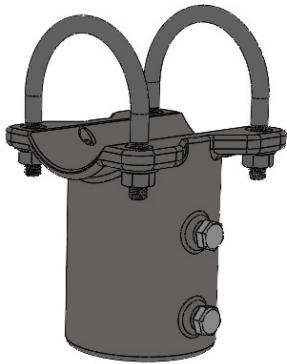

Pole Cap for 2-IN Post

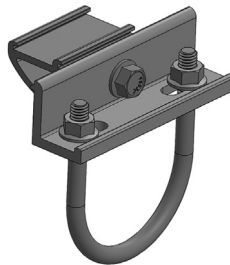

Pipe Mount

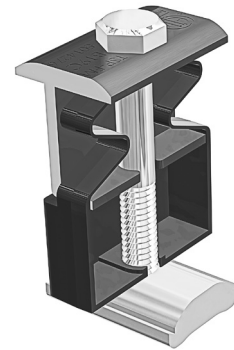

5050 Clamp



Ground Lug



Rail End Cap



Wire Clip

Optional Components (sold separately)

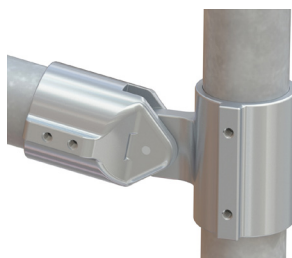

Swivel Tee Fitting

Use 2-IN Swivel Tees when cross bracing is required. Use one per vertical post.

Item code: **89778**

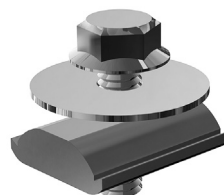

MLPE Mount

Use MLPE Mounts to attach microinverters or optimizer to rails. Use one per module.

Item code: **88481 (Bag of 12)**

Tools Required

- Post Hole Digger or Power Auger
- Torque Wrench (0-240 in-lbs recommended)
- Socket Driver with a 1/2-inch Socket
- 3/16-inch Allen Head Driver Socket
- String Line and Level, or Transit
- Plumb Bob
- Tape Measure
- Chop Saw with metal-cutting blade (only required if cutting aluminum rails)
- Pipe Cutter for cutting 2” steel pipe (reciprocating saw or portable bandsaw could be used)

Torque Specifications

Rail Adapter on Pipe Mount Clamp	144 in-lbs (12 ft-lbs)
U-Bolt Nuts on Pipe Mount Clamp	72 in-lbs (6 ft-lbs)
Swivel Socket Tees	204 in-lbs (17 ft-lbs)
Pole Cap U-bolts and Set Screws	204 in-lbs (17 ft-lbs)
Rail Splice Lock bolts	144 in-lbs (12 ft-lbs)
MLPE Mount (optional part, not included in kits)	144 in-lbs (12 ft-lbs)
Ground Lug	144 in-lbs (12 ft-lbs)
5050 Clamp as Mid-Clamp	144 in-lbs (12 ft-lbs)
5050 Clamp as End Clamp	72-108 in-lbs (6-9 ft-lbs)
Ground Lug	144 in-lbs (12 ft-lbs)
IlSCO SGB-4 Module Frame Ground lug (optional part, not included in kits)	144 in-lbs (12 ft-lbs)

COMPONENTS LIST - GROUND MOUNT KITS							
	Part Description	3 Modules (per column)			4 Modules (per column)		
		GM KIT "A"	GM KIT "B"	GM KIT "C"	GM KIT "A"	GM KIT "B"	GM KIT "C"
		Item#: 90057 132" Rails - 4 Posts -	Item#: 90064 132" Rails - 2 Posts -	Item#: 90842-A 132" Rails - 0 Posts -	Item#: 90798-A 186" Rails - 4 Posts -	Item#: 90804-A 186" Rails - 2 Posts -	Item#: 90835-A 186" Rails - 0 Posts -
Part #	Part Description	Quantity					
90466	3.1 Rail Mill Finish 66IN (each)	4	4	4			
90538	3.1 Rail Mill Finish 93IN (each)				4	4	4
90682	Pipe Cap for 2-IN Post	4	2		4	2	
89556-B	3.1 Rail Splice	2	2	2	2	2	2
88955	Pipe Mount with U-Bolt	4	4	4	4	4	4
88450	5050 Clamp Black 30mm - 40mm	8	8	8	10	10	10
89846	3.1 End Cap	4	4	4	4	4	4
88504	Ground Lug	1	1	1	1	1	1
88474	Wire Management Clip	8	8	8	8	8	8

Items below are not included with kits but may be required (sold separately)							
89778	2-IN Swivel Tee (for cross bracing)	4, if required	2, if required		4, if required	2, if required	
88481	MLPE Mount	1 per module to attach microinverters or optimizer to rails					

System Design

- Make a drawing showing the dimensions of the mount system and the location of the mounting peers.
- Read this manual before beginning installation.
- Purchase 2-inch schedule 40 pipe for vertical posts, horizontal supports and cross bracing if necessary for your snow load and wind load requirement.
- Tamarack design information assumes the array is to be on ground with no more than 15 degrees of slope.
- Tamarack Ground Mount Kits are for use in sites with Class 3 or Class 4 soil type and terrain exposure category B.
- If terrain and/or soils conditions are different, consult a structural engineer.
 - Class 3 Soil: Medium dense coarse sands, sandy gravels, very stiff silts, and clays
 - Class 4 Soil: Loose to medium dense sands, firm to stiff clays and silts, alluvial fill
- Exposure Category B is an urban, suburban or wooded area. Obstructions the size of single family dwellings must surround the structure at within 2,630 ft or 10 times the mounting structure height in all directions, whichever is greater.

Preparations for Installation

Plan the PV array layout and confirm that plans comply with local AHJ requirements and applicable building codes. Leave enough room to work safely around the array during the installation process. Some building and fire codes require minimum clearances around PV module installations.

To accommodate modules being used, the length of the rails for each column should be at least equal to the total width of all of the modules in each column, plus 1/2-inch for each 5050 clamp used between modules, plus 2-inches total for end clamping (1" on each rail end).

The Tamarack Ground Mount Kits allow for two design configurations, either three or four modules per column in landscape orientation (long side of the modules parallel to the ground).

There are 6 Ground Mount Kits available; three for 3 modules per column, three for 4 modules per column and Swivel-Tees used for cross bracing.

North to South post spacing is always constant and depends on number of modules in each column.

Mounts with 3 modules per column have 72-inch North/South spacing.

Mounts with 4 modules per column have 90-inch North/South spacing.

Some configurations require cross bracing between each North and South vertical post. Bracing requirement is based on maximum snow load, maximum wind load and array tilt angle.

You will need to determine the following information from our online Ground Mount sizing tool to purchase 2-inch schedule 40 pipe and concrete:

1. Horizontal Pipe Length*
2. Vertical Post Spacing
3. Concrete Pier depth and diameter

This information will be in the Engineering and Parts List tab in our online tool. See next page.

* Purchase 2-IN (NPS) ASTM A53 Grade B Schedule 40 Pipe, galvanized to a min of ASTM A653 G90 or ASTM A123 G35, or 2.375-IN (O.D.) Allied Mechanical Tubing with Gatorshield or FlowCoat Zinc Coating (ASTM A1057)

Use Our Online Tool to Design Your Ground Mount

<https://tamarack-configurators.cloudapps.ltd/ground-mount/>

Solar Array and Environment Details Tab

Enter the dimensions and quantity of the modules you are planning to mount and the tilt angle you desire.

Enter Environment Information

Exposure Category - B, C or D
 Snow Load
 Wind Speed
 Soil Type
 South Facing Grade
 Maximum Excavation Depth (optional)



Enter Material Costs (optional)

This will allow you to compare the cost of concrete for different pier depths and the cost of steel pipe with and without cross-bracing.

Understructure Configuration

This tab will allow you to choose 3 or 4 module rows and whether to use front to back bracing on the pipe structure. The boxes below pier sizing options give you the hole depth required and a relative cost per pier for various pier sizes.

Engineering and Parts List

This tab will give you the structural details and a list of which Ground Mount Kits you will need for your installation.

Part Number	Description
90057	3 Modules per Column with 4 vertical Poles
90064	3 Modules per Column with 2 vertical Poles
90842-A	3 Modules per Column with 0 vertical Poles
90798-A	4 Modules per Column with 4 vertical Poles
90804-A	4 Modules per Column with 2 vertical Poles
90835-A	4 Modules per Column with 0 vertical Poles
89778	2-inch Swivel Tee-Fitting (optional; for cross bracing)
88481	MLPE Mount

Foundation Hole and Post Layout

Using batter boards and string lines, lay out your footing locations for both the front and back east-west rows of piers. This will consist of two string lines, one for the front east-west row of piers and one for the back row of piers. Be sure that the two strings are parallel to each other, and with the proper spacing between the two east-west rows (this spacing depends on whether you use columns of 3 or 4 modules - see page 8).

Once you have the two east-west string lines properly in place, place the first north-south string across one end, at the location where you want the first piers to be located. The first two piers (front and back) will be located directly below where the north-south string and two east-west strings cross.

Continue to add batter boards and north-south strings, spaced apart according to the proper east-west pier spacing. If you only need four piers (two front and two rear), you will only need two north-south strings. If you need six piers total, you will need three north-south strings. Eight piers would require four strings, etc.

Make sure that the strings are in the proper locations and adjust as needed. Make sure that the whole layout is square and aligned evenly.

Directly below where each north-south string crosses one of the east-west strings will be the location of the center of a foundation hole and pier. Use a plumb bob to locate those points on the ground and drive a stake at each location. These are the centers of where the holes will be excavated. Once the stakes are driven, the strings may be temporarily removed.

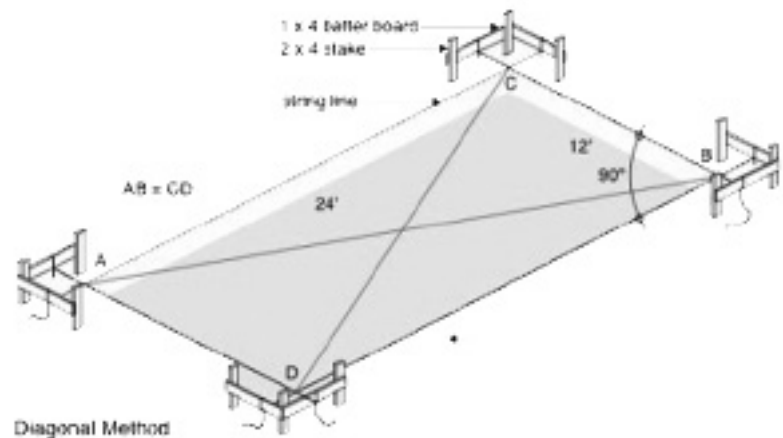
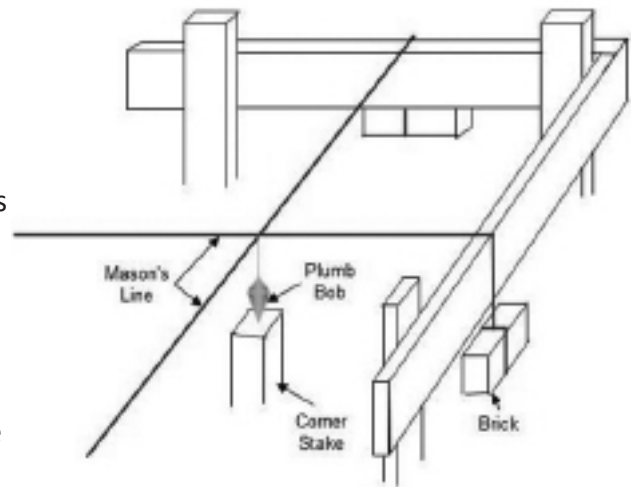

Excavating Holes for Concrete Piers

Using a 12-inch power auger, excavate footings at marked locations to the depth required. See Charts on page 10 and 11. Re-install the layout strings to make sure that the holes are excavated at the proper locations and adjust the hole centers if necessary. Clean out as much loose soil as you can from the augered holes.

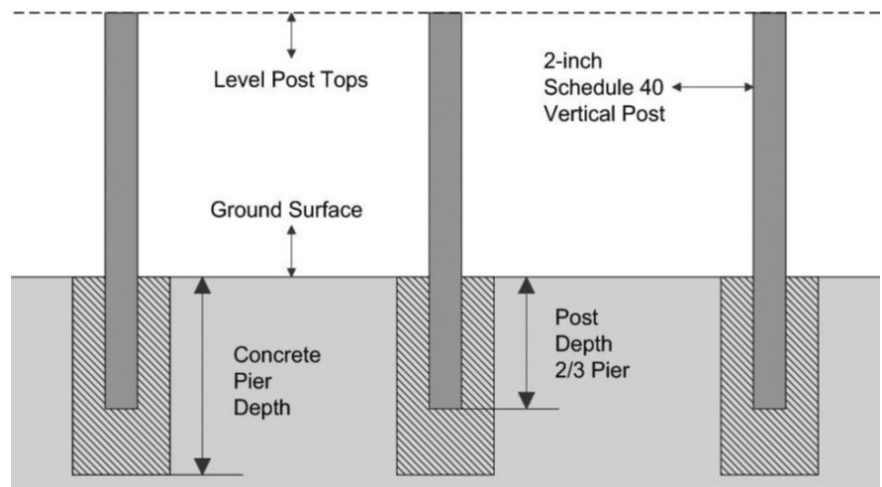

Assemble Pipe Structure and Prepare for Concrete

While there is a number of methods that can be used to set the vertical pipe posts in concrete, we recommend the following method which makes it easier to align and level the pipe sub-structure:

Using the Pole Caps for 2-IN posts and sections of 2-INh pipe, assemble both the front and back 2-inch pipe horizontal beams, placing the Pole Caps at the proper distance apart based on the required pier spacing. Tighten the Pole Capg U-bolts just enough to hold them in place, but not fully tightened as their location may need to be adjusted later. Leave the horizontal pipe longer than necessary until the rails are assembled. This will allow for some adjustment from side to side.

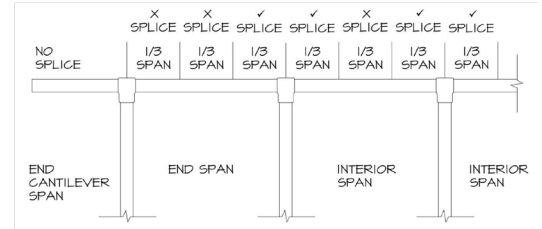

NOTE: Schedule-40 steel pipe is available in lengths up to 21 feet. For arrays with more than 3 or 4 columns, you may need to splice two sections of pipe together. Couplings are not permitted in the end cantilever section, in the outer 2/3 of an end span or in the middle 2/3 of an interior span. (See picture above. You can splice pipe sections in the center of a Pole Cap, or by using a 2-inch threaded pipe coupling or our 90705 Pipe Coupler, which can be used on pipe that is not threaded. If splicing pipes over a Pole Cap, pipe ends must have less than 1/2-inch between pipe ends.

The height of the north (rear) posts will be determined by the tilt angle of the array. See page 7.

North - South post spacing is:

- 72" for columns of 3 modules
- 90" for columns of 4 modules.

Support the horizontal pipe beams at the proper height above the ground level using X-brace pipe supports made with 2x4 or 2x6 wood boards (or use commercially available pipe supports). The X-braces can each be made using two boards with holes drilled at the proper location, and a connected together with a single bolt and nut to act as a hinge.

Center the Pole Caps on the 2-inch pipes directly above the excavated holes.

Level the two horizontal beams; make sure they are straight and parallel with each other, and at the proper distance apart. The two boards of each X-brace can be pulled closer together at the bottom to raise the beam or drawn further apart to lower the beam to achieve level. Hold the X-braces in place with another board going down to the ground set at 90° to the X-braces as shown in the photos. Fine adjustment to level can also be done using



shims between the beam pipes and the X-Braces. If the horizontal beams are long, you can do this in sections for easier handling. Check for array tilt consistency along the entire length of array and adjust if necessary.

Use stakes at the bases of the brace boards to hold them in place. Steel concrete form stakes are perfect for this purpose, but you can also use wooden stakes.

Tops of the concrete piers need to be above ground level to keep water from pooling around the pipe posts. Use of Sonotube material to form a pedestal above the in-ground section of the concrete piers. Use 12-inch diameter Sonotube material

or equivalent. It is only necessary for the tubes to be located from the ground level up. They do not need to extend into the holes. 6-inches above ground is plenty to produce a proper pier pedestal.

Temporarily hang Sonotube sections from the horizontal beams at each vertical post location before installing the pipe posts into the assembly. They will need to remain suspended until the concrete is poured, and then placed into position above ground level during the concrete pour.

NOTE: For systems with North-South cross bracing, slide a Swivel Socket Tee onto each of the vertical pipe posts before installing them onto the horizontal beams. Tighten the set screws just enough to hold them to the pipes at some point near the center so that they are not in the way as you construct the rest of the pipe sub-structure. Their exact position will be determined and set later. If you neglect to do this before the concrete is poured, you will need to remove the horizontal pipe beams after the concrete has set in order to slide the Swivel Socket Tees onto the posts.

Next, hang the pipe posts from the Pole Caps. Insert pipe posts into each hole, and lift them up through the suspended Sonotube rings and into the bottoms of the Pole Caps. Make sure that each post is fully inserted into each Pole Cap. Try not to allow the posts to contact the soil on the sides or bottom of the holes. If they do, do not allow any soil material to remain on or inside the pipes. Tighten the set screws on the Pole Caps just enough to hold the vertical pipes in place. Ensure that the bottom of each pipe extends 2/3 of the way to the bottom of the hole. Then tighten the Pole Caps set screws on the vertical pipe to make sure that they stay in place.

Make any horizontal adjustments to the Pole Caps required to center the vertical pipe in the holes. Do a final check to make sure that the horizontal beams are level and properly located at the correct spacing between each other, and that the posts are plumb and centered in the holes.



Pouring Concrete

Pour mixed concrete (minimum 2500 psi) into excavated holes. Use a tamping tool (a length of 2x4 works well) to compress the wet concrete, making sure there are no trapped air pockets. As you fill the hole with concrete make sure that the vertical post remains centered and plumb.

Fill the holes to ground level, and then lower the previously hung Sonotube sections down onto the wet concrete, keeping the pipe posts centered. Twist or shake the Sonotube to make sure it is in full contact with the wet concrete. Use a short level to make sure that the sides of the Sonotubes are plumb and fill the tubes with concrete. Trowel the tops of the concrete into a slight dome formation to allow for water drainage. See drawing at right.

Allow the concrete to cure for at least 24 hours before proceeding.



System With Cross Braces

Skip this step if cross bracing is not required.

On each North-South post pair, loosen the set screws on the Flex Tees which were previously slid onto the vertical pipe posts.

Slide the Flex Tee Socket on the rear (north) post all the way to the bottom and slide the one on the front (south)

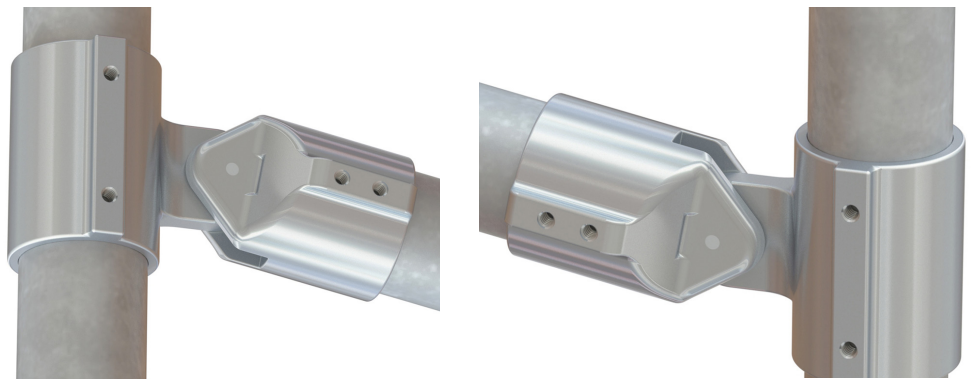

post to the Socket Tee on the top of the vertical pipe. (this will allow space as you insert the brace pipes).

Face and align the two swivel sockets towards each other – the socket on the raised south Swivel Tee facing down towards the Swivel Tee on the north post. Tighten the set screws just enough to hold both Swivel Tees in place.

Measure the length of pipe needed to be the brace pipe. The pipe ends can be inserted 2 inches into each Swivel Tee, but in order to insert the pipe into both Tees, the pipe will need to cut shorter. Measure from the very inside of one of the Swivel Tees to the outside edge of the other Swivel Tee. Cut the pipe for the brace to this length.

To assemble the brace, first loosen the set screws on the Swivel Socket Tee at the bottom of the north post. Slide one end of the brace pipe fully into this Swivel Tee's socket until it bottoms out, and tighten the set screw on the brace pipe, but do not tighten the set screws on the post pipe yet.

Angle the brace pipe up toward the Swivel Tee on the south post. After loosening the set screws on this Swivel Tee, guide the end of the pipe into the socket and lower the Swivel Socket Tee assembly down until the pipe end is fully seated into the socket and tighten the set screw onto the brace pipe.

Loosen the set screws on both of the Swivel Tees that attach to the vertical posts. Position the brace assembly up so that there no more than 6-inches from the center of the north-post Swivel Socket Tee to the surface of the concrete, and no more than 6-inches from the center of the south horizontal beam and the center of the Swivel Socket Tee on the south post. See drawing at right.

Repeat this whole process for installing the cross braces on each north/south pair of posts. There may need to be changes to the lengths of the brace pipes from location to location, especially if the installation site is not completely level.

3 Modules per Column

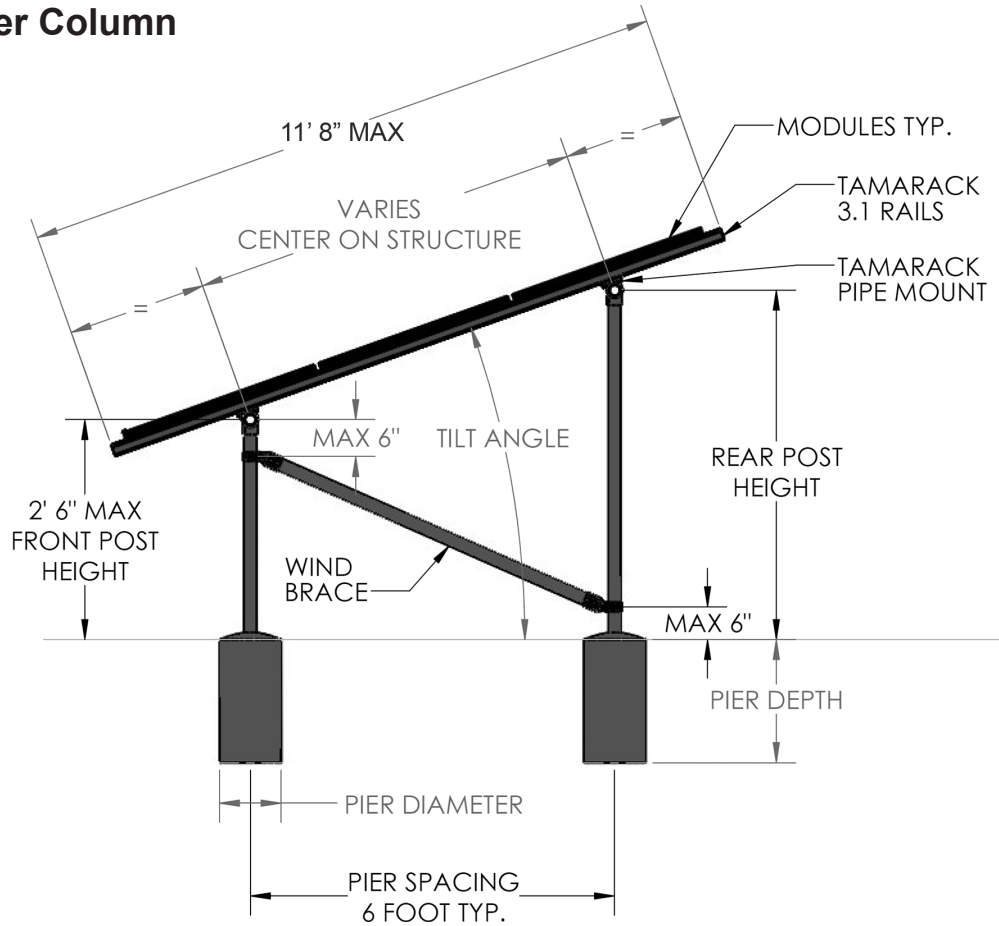

4 Modules per Column

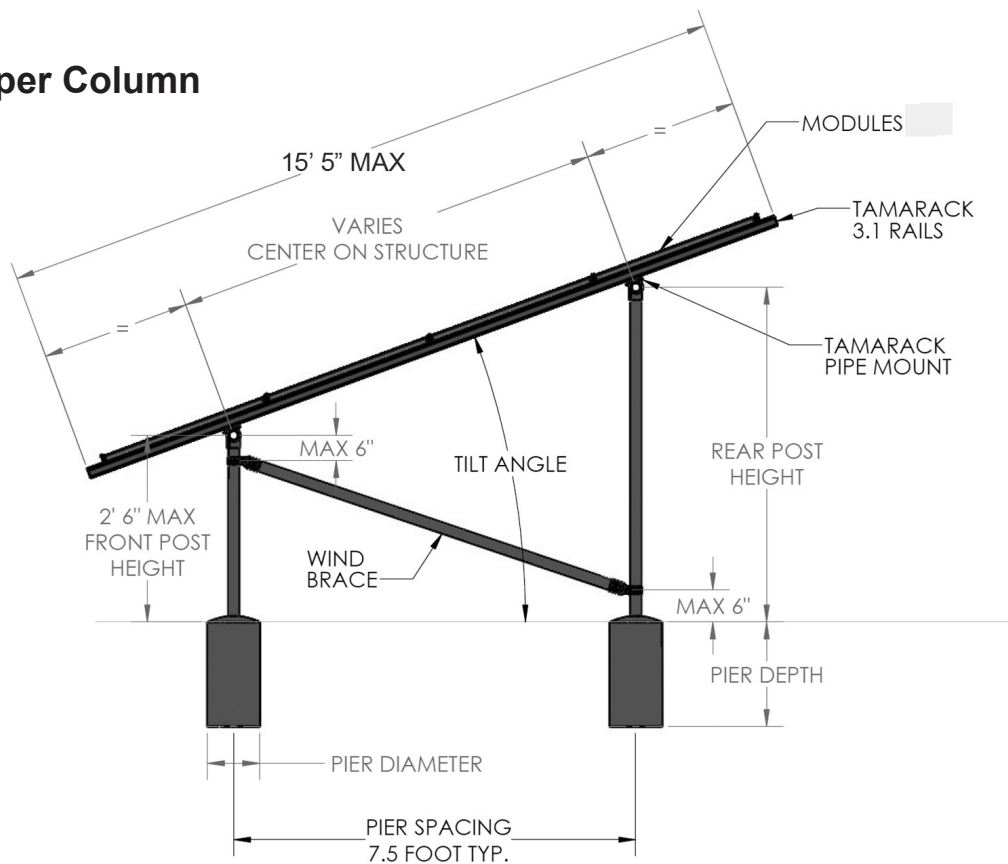

Assemble Module Support Rails

You will need two rail assemblies per column. Rails for 4 modules consist of two 93-inch 3.1 rails connected with a Rail Splice. The maximum module with that can be accommodated on this rail length is 45-inches.

Rails for 3 modules consist of two 66-inch 3.1 rails connected with a Rail Splice. The maximum module with that can be accommodated on this rail length is 43-inches.

Insert the RailSplice 5-inches into one rail end. Install one of the provided Rail Splice Locks (roughly centered in the 5-inch insertion) and tighten to hold it in place. Slide the second section of rail over the splice until it contacts the first section of rail and install the second Rail Splice Lock. Tighten both Rail Splice Lock bolts to 144 inch-pounds (12 foot-pounds). Either locking bolt may be loosened and moved slightly if it interferes with mid-clamp placement when installing modules

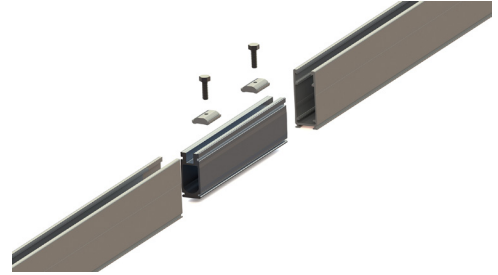

Attach Pipe Mount to Rail Assemblies

Each Pipe Mount consists of a Rail Adapter loosely bolted to an aluminum extrusion and a U-bolt with hardware. Attach Pipe Mount to all of the rails at this time. Position the Rail Adapter into the two features on the bottom of the rail, and finger tighten the bolt to allow for repositioning of the Pipe Mount on the rails.

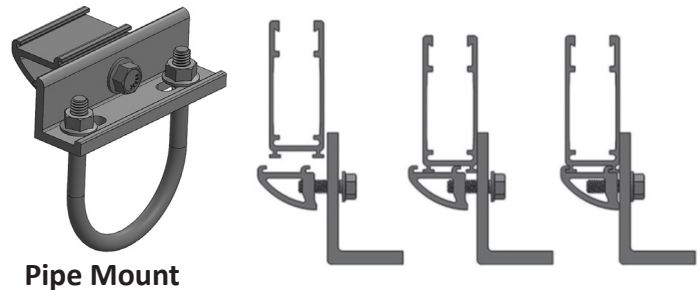

Pipe Mount

Install Rail Assemblies onto the Pipe Substructure

Mark the location of the rails on the lower horizontal pipe, leaving approximately 1/2-inch of space between the columns of modules.

Install the module rails to the horizontal pipes at the location marks using the U-bolts on the Pipe Mounts. Finger-tighten the flange nuts on the Pipe Mount U-bolts.

Square and center the rails at each end of the horizontal pipes and tighten their hardware to 72 inch-pounds (6 foot-pounds). Run a string line between the end rails and align the remaining rails. You will need to loosen the Pipe Mount U-bolt flange nuts in order to slide the rail up or down for alignment. Tighten the U-bolt nuts to 72 inch-pounds (6 foot-pounds) and the flange bolts on the rail clamps to 144 inch-pounds (12 foot-pounds) on all rail assemblies.



Attach Pipe Mount to Rail

Grounding the Array

Tamarack rails and approved PV modules are bonded by 5050 Clamps and Splices. The 5050 Clamps achieve bonding to the module frames through stainless-steel pins in the clamping surface of the clamp tops, which penetrate module frame coatings. The rails and channel nuts are bonded because of the conductive surface of the mill finish aluminum used in the rail construction.

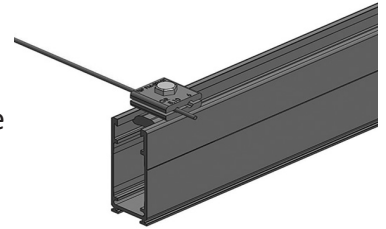

SolarEdge Optimizers and Enphase Microinverters are bonded to the rails with the Tamarack MPLE adapters. Other brands and models of power optimizers or microinverters may require a different grounding method.

The Tamarack Pipe Mount Clamps provide grounding continuity between the rail assemblies and the horizontal pipe.

The Pole Caps provide a grounding path between all connected sections of pipe.

Because all of the elements of an entire unified ground mount array are bonded electrically, the Tamarack Solar Ground Mount only requires a single Ground Lug for the grounding connection.

Use a Ground Clamp to bond a grounding conductor to one of the rails. It does not matter which rail in the array is used, but the rail closest to the final grounding connection should be chosen to reduce the grounding path as much as possible.

The Ground Clamp works with #10 - #6 AWG copper grounding conductors. A #6 AWG solid grounding conductor should be used if the conductor is in any way potentially exposed to damage.

NOTE: If the PV module that you are using is not listed on our approved module list at the end of this manual, the grounding method described above may not meet UL standards for grounding. In this case the proper grounding method would be to use a Module Frame Ground Lug on each module frame in the array, and connecting all of the frame grounding lugs together with a copper grounding conductor.

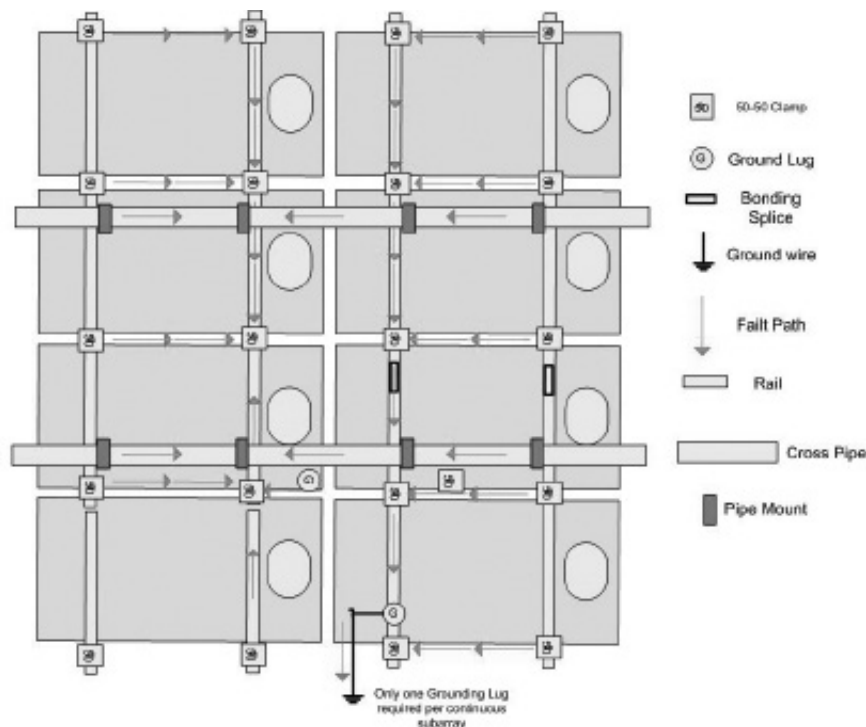

Module Level Power Electronics

If you are using rail mounted Module Level Power Electronics (MLPE), it is easiest install them before installing the solar modules onto the rail assemblies.

Use Tamarack MLPE Adapters (sold separately, see page 6) to attach Enphase microinverters or SolarEdge Optimizers to the rails. Tighten the bolts with a 1/2-inch socket to the specified torque.

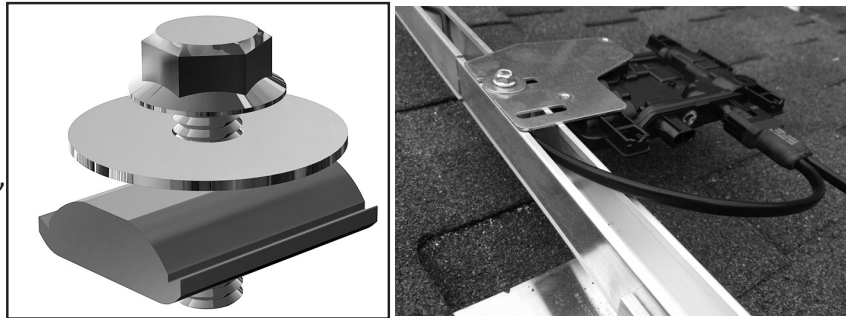

Wire Management

Place the array's electrical conductors and connectors into the cavity of the rail channels. Wires can be run through the splices, but check to be sure that they do not conflict with the self-drilling fasteners.

Install the Wire Management Clips where necessary to keep wires in the channels. If you are using MLPE, use these clips to keep the MLPE wiring in place as it is laid into the rail channels.

On a ground mount installation, these clips can be installed from behind the array as necessary to keep wires in place. Use as many as needed to ensure that the wires stay in the rail channels over the years.



PV Module Installation

To center the column of modules on the rails determine how much longer mounting rail length is than modules being installed. Calculate using width of PV modules, number of modules per column and 1/2-inch spacing between modules for mid-clamps.

Start module installation at bottom of the first column.

Place a solar module on the first set of rails so that it is the calculated distance from the lower end of the rails and secure it in place with a 5050 clamp on each rail. Since these clamps will be used as end clamps, place the side of the top clamp with two pins toward the modules. Center the first module east to west over the rails and hold in place. Make sure that the module is straight and level on the rails and tighten the two end clamp bolts to 96 inch-pounds (8 foot-pounds).

Install one 5050 Clamp in each rail on the other side of the first module and slide it down so that the inside of the clamp contacts the frame of the first module. The springs will hold the clamps in place prior to tightening. Place the second module on the rails, align it with the first module, and slide down and fully into the two mid-clamps. Tighten the mid-clamp bolts to 144 inch-pounds (12 foot-pounds) to fully secure the module.

Install the third module (and fourth module if installing columns of four) and mid-clamps on the rails in the column in the same manner, aligning the corners of the modules as you go up the column. Check to make sure that the modules in this first column are all even and straight, and where you want them to be.

On the top edge of the last module of the first column, install the 5050 Clamps so that the sides with the two stainless-steel pins are facing in toward the module frame, and the clamp is tight up against the module frame. Tighten the two end clamp bolts to 96 inch-pounds (8 foot-pounds).

Install subsequent columns of modules in the same manner. Leave 1/2-inch of spacing between the columns. Make sure that all of the rails are centered between the north and south beams and extend past the south beam the same distance at the bottom end. Use a string line as an alignment aid, or just do this with line-of-sight

Do a final check to be sure that all bolts and installation hardware on the array is properly tightened to the specified torque values.

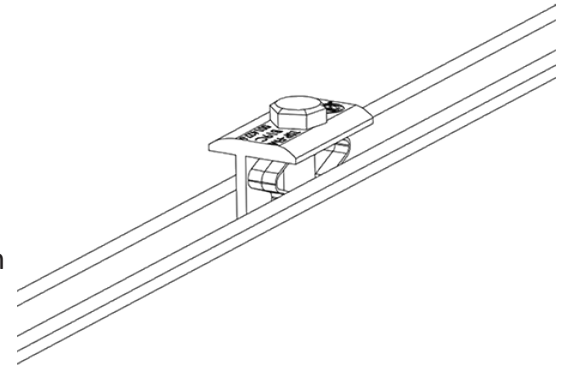
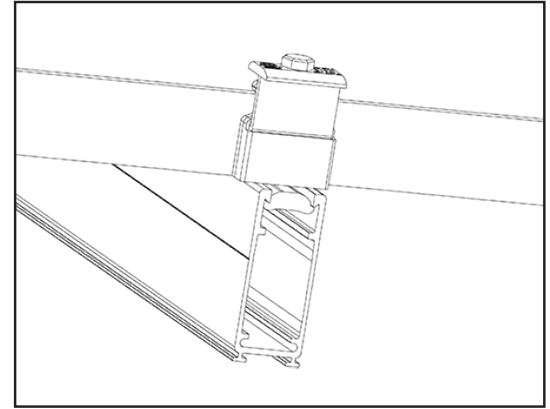

Module Compatibility

The solar modules listed on the next two pages have been certified to meet UL 2703 standards when installed with a Tamarack Solar FM Rail System.

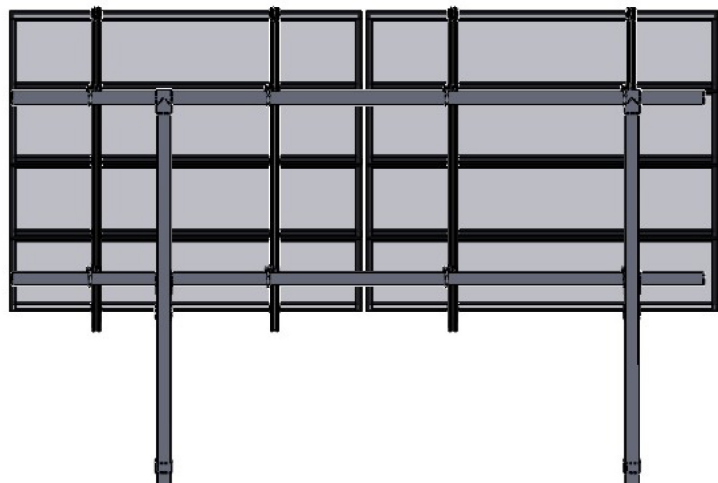

Back View

Certified Module List for UL2703 Listing Program

Manufacturer	Model
Aleo	P18/P19/S18/S19/S59/S79.
AU Optronics	PM Series
Astronergy	modules with 30, 35, 40, and 45 mm frames aaSMbbyyC/zz-xxx Where "aa" can be CH or A; "bb" can be 60, 66, or 72; "yy" can be blank, 10 or 12; "C" can M, P, M(BL), M-HC, M(BL)-HC, P-HC, M(DG), or M(DGT); and "zz" can be blank, HV, F-B, or F-BH
Auxin	modules with 40 mm frames AXN6y6zAxxx Where "y" can be M or P; "z" can be 08, 09, 10, 11, or 12; and "A" can be F or T
Axitec	Modules with 35 and 40 mm frames AC-xxxY/aaZZb Where "Y" can be M, P or MH; "aa" can be blank, 125- or 156-; "ZZ" can be 54, 60, 72, 120, or 144; "b" can be S
Boviet	Boviet modules with 35 and 40mm frames - BVMZZaaYY-xxxBcc Where "ZZ" can be 66 or 76; "aa" can be 9, 10 or 12; "YY" is M or P; and "B" can be blank, L or S; and "cc" can be blank, H, H-BF, H-BF-DG, H-HC, H-HC-BF, H-HC-BF-DG, HC-BF or HC-BF-DG]
BYD	BYD modules with 35 mm frames BYDxxxAY-ZZ Where "A" can be M6, P6, MH or PH; "Y" can be C or K; and "ZZ" can be 30 or 36
Canadian Solar	Canadian Solar modules with 30, 32, 35, and 40 mm frames - CSbY-xxxZ Where "b" can be 1, 3 or 6; "Y" can be H, K, L, N, P, U, V, W, X or Y; and "Z" can be M, P, MS, PX, M-SD, P-AG, P-SD, MB-AG, PB-AG, MS-AG, or MS-SD
CentrsoSolar	C and E series.
CertainTeed	CertainTeed modules with 35 and 40 frames CTxxxYZZ-AA Where "Y" can be M, P, or HC; "ZZ" can be 00,01, 10, or 11; and "AA" can be 01, 02, 03, or 04
CSUN	Csun modules with 35 and 40 mm frames - YYxxx-zzAbb Where "YY" is CSUN or SST; "zz" is blank, 60, or 72; and "A" is blank, P, M or MM; "bb" is blank, BB, 5BB, BW, or ROOF
Dehui	Dehui modules with 30, 35 and 40mm frames - DH-MYYYYZ-xxx Where "YYYY" can be 760, 772, 860, 872; and "Z" can be B, F or W
Eco Solargy	ORION 1000 ECOXXH156P-60, APOLLO 1000 ECOXXT156M-60, and APOLLO 1000 ECOXXA156M-60.
ET Solar	30, 35, 40, and 50 mm frames ET-Y6ZZxxxAA Where "Y" can be P, L, or M; "ZZ" can be 60, 72 or 72BH; and "AA" can be GL, WB, WW, BB, WBG, WWG, WBAC, WBCO, WWCO, WWBCO or BBAC
GCL	40mm frame: GCL-P6/72, 35mm frame: GCL-P6/72, GCL-P6/72H, GCL-M6/72, GCL-M6/72H, 35mm frame (Black frame): GCL-P6/60, GCL-M6/60
GigaWatt Solar:	Gigawatt modules with 40 mm frames - GWxxxYY Where "YY" can be either PB or MB
Hanwha Q-Cells	Modules with 32, 35, 40, and 42mm frames aaYY-ZZ-xxx where "aa" can be Q, or B.; "YY" can be PLUS, PRO, PEAK, LINE PRO, LINE PLUS, PLUS DUO or PEAK DUO; and "ZZ" can be G3, G3.1, G4, G4.1, L-G2, L-G2.3, L-G3, L-G3.1, L-G3y, L-G4, L-G4.2, L-G4y, LG4.2/TAA, BFR-G3, BLK-G3, BFR-G3.1, BLK-G3.1, BFR-G4, BFR-G4.1, BFR G4.3, BLK-G4.1, G4/SC, G4.1/SC, G4.1/TAA, G4.1/MAX, BFR G4.1/TAA, BFR G4.1/MAX, BLK G4.1/TAA, BLK G4.1/SC, EC-G4.4, G5, G5/SC, G5/TS, BLK-G5, BLK-G5/SC, BLK-G5/TS, L-G5, L-G5.1, L-G5.2, L-G5.2/H, L-G5.3, G6, G6/SC, G6/TS, G6+/TS, G6+, BLK-G6, L-G6, L-G6.1, L-G6.2, L-G6.3, G7, BLK-G6+, BLK-G6+/AC, BLK-G6+/HL, BLK-G6+/SC, BLK-G6/TS, BLK-G6+/TS, BLK-G7, G7.2, G8, BLK-G8, G8+, BLK-G8+ L-G7, L-G7.1, L-G7.2, L-G7.3, L-G8, L-G8.1, L-G8.2, L-G8.3, L-G8.3/BFF, L-G8.3/BFG, L-G8.3/BGT, ML-G9, BLK ML-G9, ML-G9+, BLK ML-G9+, ML-G10, BLK ML-G10, ML-G10+, BLK ML-G10+, ML-G10.a, BLK ML-G10.a, ML-G10.a+, BLK ML-G10.a+, XL-G9, XL-G9.2, XL-G9.3, XL-G9.3/BFG, XL-G10.2, XL-G10.3, XL-G10.c, XL-G10.d, XL-G10.d/BFG or XL-G10.3/BFG
Hansol	Hansol modules with 35 and 40 frames HSxxxYY-zz Where "YY" can be PB, PD, PE, TB, TD, UB, UD, or UE; and "zz" can be AH2, AN1, AN3, AN4, HH2, HV1, or JH2]
Heliene	Heliene modules with 40 mm frames - YZZxxxA Where "YY" can be 36, 60, 72, 96, 120 or 144; "ZZ" can be HC, M, P, or MBLK; and "A" can be blank, HomePV, or Bifacial]
HT Solar	HT60-156(M) (NDV) (-F), HT 72-156(M/P)
Hyundai	Hyundai modules with 33, 35, 40 and 50 mm frames - HiY-SxxxZZ Where "Y" can be A, D or S; "S" can be M or S; and "ZZ" can be GI, HG, HI, KI, MI, MF, MG, PI, RI, RG, RG(BF), RG(BK), SG, TI or TG
ITEK	40 and 50 mm frames IT-xxx-YY Where "YY" can be blank, HE, or SE, or SE72
JA Solar	30, 35, 40 and 45 mm frames JAyzz-bbww-xxx/aa Where "yy" can be M, P, M6 or P6; "zz" can be blank, (K), (L), (R), (V), (BK), (FA), (TG), (FA)(R), (L)(BK), (L) (TG), (R)(BK), (R)(TG), (V)(BK), (BK)(TG), or (L)(BK)(TG); "bb" can be 48, 60, or 72; "ww" can be D09, S01, S02, S03, S06, S09, S10, or S12; and "aa" can be BP, MR, SI, SC, PR, 3BB, 4BB, 4BB/RE, 5BB
Japan Solar	JPS-xxxP-60 (35mm), JPS-xxxM-60 (35mm), JPS-xxx-P-72 (40mm), JPS-xxxM-60-BB (35mm), JPS-xxx-P-72-BB (40mm)
Jinko	35 and 40 mm frames JKMYxxxZZ-aa Where "Y" can either be blank or S; "ZZ" can be M, P, or PP; and "aa" can be blank, 60, 60B, 60H, 60L, 60BL, 60HL, 60HB, 60HBL, 6HBL-EP, 60-J4, 60B-J4, 60B-EP, 60(Plus), 60-V, 60-MX, 7RL3-V, 7RL3-TV, 72, 72B, 72-J4, 72B-J4, 72(Plus), 72-V, 72H-V, 72L-V, 72HL-V, 72-MX, 72H-BDVP, 72HL-TV, or 72HL-V-MX3
Kyocera	KU26x-6MCA where x is 0 or 5.
LG	[LG modules with 35, 40, and 46 mm frames - LGxxxYaZ-bb Where "Y" can be A, E, M, N, Q, S; "a" can be A, 1, 2 or 3 "Z" can be C, K, T, or W; and "bb" can be A3, A5, A6, B3, B6, E6, G3, G4, J5, K4, L5, N5, V5 or V6]
LONGi	[Longi modules with 30, 35 and 40 mm frames - LRA-YYZZ-xxxM Where "a" can be 4, 5 or 6; "YY" can be blank, 60 or 72; and "ZZ" can be blank, BK, BP, HV, PB, PE, PH, HBD, HIB, HIH, HPB, HPH, or HIBD]
Mission Solar	33 and 40 mm frames MSEbbxxxZZaa Where "bb" can be blank or 60A; "ZZ" can be blank, MM, SE, SO, SQ, SR, or TS; and "aa" can be blank, 1J, 4J, 4S, 5K, 5T, 60, 6J, 6S, 6W, 8K, 8T, or 9S
Mitsubishi	Mitsubishi modules with 46 mm frames - PV-MYxxxZZ Where "YY" can be LE or JE; and "ZZ" can be either HD, HD2, or FB

Certified Module List for UL2703 Listing Program

Manufacturer	Model
NSP	D6M and D6P
Panasonic	30 mm frames EVPVxxxA, Where "A" can be blank or KPanasonic modules with 35 and 40 mm frames VBHNxxxYYZZA Where "YY" can be either KA, RA, SA or ZA; "zz" can be either 01, 02, 03, 04, 06, 06B, 11, 11B, 15, 15B, 16, 16B, 17, or 18; and "A" can be blank, E, G, or N
Peimar	40 mm frames SbxxxYzz Where "b" can be G, M or P; "Y" can be M or P; and "zz" can be blank, (BF) or (FB)
Phono Solar	Phono Solar modules with 35, 40, and 45 mm frames - PSxxxY-ZZ/A Where "Y" can be M, M1, MH, M1H, M4, M4H or P; "ZZ" can be 20 or 24; and "A" can be F, T, U, UH, or TH]
Risen	RSM72-6 (MDG) (M), RSM60-6
REC Solar	REC modules with 30, 38 and 45 mm frames - RECxxxYYZZ Where "YY" can be AA, M, NP, NP2, PE, PE72, TP, TP2, TP2M, TP2SM, TP2S, TP3M or TP4; and "ZZ" can be blank, Black, BLK, BLK2, SLV, 72, or Pure
Renesola	Virtus II with module ratings of 250-260 in increments of 5. 156 series with module ratings of 270-275.
S-Energy	S-Energy modules with 35 and 40mm frames - SABB-CCYYY-xxxZ Where "A" can be C, D, L or N; "BB" can be blank, 20, 25, 40 or 45; "CC" can be blank, 60 or 72; "YYY" can be blank, BDE, MAE, MAI, MBE, MBI, MCE or MCI; and "Z" can be V, M-10, P-10 or P-15
Seraphim Energy Group	Seraphim modules with 30, 35, and 40 mm frames - SEG-aYY-xxxZZ Where "a" can be blank, 6 or B; "YY" can be blank, MA, MB, PA, or PB; and "ZZ" can be blank, BB, BG, BW, HV, WB, WW, BMB, BMA-HV, BMA-BG, BMB-HV
Seraphim USA	Seraphim modules with 30, 35, 40 and 50 mm frames - SRP-xxx-YYY-ZZ Where "xxx" is the module power rating; and "YYY" can be BMA, BMD, 6MA, 6MB, 6PA, 6PB, 6QA-XX-XX, and 6QB-XX-XX; ZZ is blank, BB, BG or HV
Sharp	60 and 72 NUSA-xxx/NUSC-xxx
Silfab	Silfab Modules with 35 and 38 mm frames - SYY-Z-xxxAb Where "YY" can be IL, SA, LA, SG or LG; "Z" can be blank, M, P, or X; "A" can be blank, B, H, M, N; and "b" can be A, C, L, G, K, T, U or X
SolarWorld	Sunmodule Plus, Protect, Bisun, XL, Bisun XL, may be followed by mono, poly, duo, black, bk, or clear; modules with 31, 33 or 46 mm frames SW-xxx, SolarWorld Sunmodule Plus, Protect, Bisun, XL, Bisun XL, may be followed by mono, poly, duo, black, bk, or clear; modules with 33 mm frames SWA-xxx
Solaria	40 mm frames PowerXT xxxY-ZZ Where "Y" can be R or C; and "ZZ" can be AC, BD, BX, BY, PD, PM, PM-AC, PX, PZ, WX or WZ
Sonali	SS 230 - 265
SunEdison	SunEdison Modules with 35, 40 & 50 mm frames - SE-YxxxZABCDE Where "Y" can be B, F, H, P, R, or Z; "Z" can be 0 or 4; "A" can be B,C,D,E,H,I,J,K,L,M, or N ; "B" can be B or W; "C" can be A or C; "D" can be 3, 7, 8, or 9; and "E" can be 0, 1 or 2
Suniva	Suniva modules with 35, 38, 40, 46, and 50 mm frames - OPTxxx-AA-B-YYY-Z and MVXxxx-AA-B-YYY-Z Where "AA" is either 60 or 72; "B" is either 4 or 5; "YYY" is either 100,101,700,1B0, or 1B1; and "Z" is blank or B
Sunpower	Sunpower standard (G3 or G4) or InvisiMount (G5) 40 and 46 mm frames - SPR-Zb-xxx-YY Where "Z" is either A, E, P or X; "b" can be blank, 17, 18, 19, 20, 21, or 22; and "YY" can be blank, BLK, COM, C-AC, D-AC, E-AC, BLK-E-AC, G-AC, BLK-C-AC, or BLK-D-AC
SunSpark	40 mm frames SYY-xxxZ-A Where "YY" can be MX or ST; and "Z" can be M, MB, M3, M3B, P or W; and "A" can be 60 or 72
Suntech	35, 40 and 50mm frames STPxxx-y-zz/aa Where "y" is blank or S; and "zz" can be 20, 24, A60 or A72U; and "aa" can be Vd, Vem, Vfw, VfH, Wdb, Wde, Wd, or Wfhb
Talesun	Talesun modules with 30, 35 and 40mm frames - TA6yZZaaxx-b Where "A" can be D or P, "y" can be blank, F, G, H, I, or L; "ZZ" can be 60 or 72; "aa" can be M, M(H), or P; and "b" can be blank, B, T, or (H)
Tesla	Tesla modules with 40 mm frames - TxxxY Where "Y" can be H or S
Trina Solar	Trina Modules with 30, 35, 40 and 46mm frames - TSM-xxxYYZZ Where "YY" can be DD05, DD06, DD14, DE14, DE15, DE15V, DEG15, DEG15VC, DE19, DEG19C.20, DE06X, PA05, PC05, PD05, PD06, PA14, PC14, PD14, PE14, or PE15 ; and "ZZ" can be blank, .05, .05(II), .08, .10, .18, .08D, .18D, 0.82, .002, .00S, 05S, 08S, .20(II), A, A.05, A.08, A.10, A.18, (II), A(II), A.05(II), A.08(II), A.082(II), A.10(II), A.18(II), H, H(II), H.05(II), H.08(II), HC.20(II), HC.20(II), M, M(II), M.05(II), MC.20(II)
Upsolar	UP-MxxxP, UP-MxxxP-B, UP-MxxxM, UP-MxxxM-B
Vikram	40 mm frames VSyy.ZZ.AAA.bb Where "yy" can be M, P, MBB, MH, MS, MHBB, or PBB; "ZZ" can be 60 or 72; "AAA" is the module power rating; and "bb" can be 03.04 or 05
Yingli	YL xxx P-29b, YLM 60, YLM 72, YGE, YGE-VG, YLM, YL xxx P-35b, YL xxx D-30b, YL xxx D-36b
Waaree	AC, Adiya 60/72 Mono/Poly Black, Adiya 60/72 Multi
Winaico	35 and 40 mm frames Wsy-xxxZa Where "y" can be either P or T; "Z" can be either M, P, or MX; and "a" can be blank or 6

Certified Power Optimizer List for UL2703 Listing Program

Manufacturer	Model
Enphase	M250-72, 250-60, M215-60, C250-72, S230, S280, IQ 6, IQ 6+, IQ 7, IQ 7+, IQ 7X, Q Aggregator
Solar Edge	P300, P320, P340, P370, P400, P405, P505, P600, P700, P730, P800p, P800s, P850, P860

Tamarack Solar Products warrants that its products will be free from defects in materials and workmanship during the warranty period. See below for specific warranty periods for various products. Tamarack Solar Products' responsibility for defective goods is limited to repair, replacement, or refund.

Tamarack Solar Products extends this limited warranty to the original, and any subsequent owner of the products, provided the products are installed properly and used for the purpose for which the products are designed. This limited warranty is assignable by purchaser and any subsequent owner of the product, provided that the product remains installed at the original installation location, and provided that any subsequent owner agrees in writing to be bound by the terms of this Tamarack Solar Products limited warranty and provides proof of purchase of the products. A change of ownership of the product does not reset the warranty period.

This limited warranty provides that products will be free of materials and manufacturing defects that materially impair the use of the product for its designed purpose. This warranty excludes: a) any defect that has not been reported to Tamarack Solar Products in writing (i) within the warranty periods set forth below and (ii) within ten (10) days after discovery of such defect; b) normal wear (including discoloration, rusting or corrosion of any pre-galvanized steel over time, or staining of any aluminum; cosmetic damage; damage resulting from negligence, accident, misuse, overloading, abuse, or improper installation including failure to follow installation instructions; the failure to comply with applicable laws including local building code limits; or damage from acts war, criminal acts, explosions, fire, vandalism, or any other events of force majeure as may apply in accordance with applicable law; c) products that have been altered, modified, or repaired without Tamarack Solar Products' prior written authorization, damage to or caused by, or defects in, third party parts or materials not sold by Tamarack Solar Products, e) any defect that arises as a result of any third party products, components, or materials used by the purchaser in conjunction with the product, which third party products or materials have not been provided for such use by or on behalf of Tamarack Solar Products or the use of which has not been expressly authorized by Tamarack Solar Products; f) products installed, used, or maintained in a manner contrary to Tamarack Solar Products documentation, including any defect that arises from the faulty handling, storage, assembly, loading, or installation of the product, or any handling, storage, assembly, loading, or installation not in accordance with the instructions given by Tamarack Solar Products, or any defect that arises from mounting the product on a building, roof, or other construction that is unsuitable for the mounting of the product; g) damage to the products during shipment, storage, or installation; h) any defect that does not materially impair the use of the product for the purpose for which it was designed. Further, the finish warranty (as defined below) shall not apply to surface oxidation or to any foreign residue deposited on a product finish, or to products installed in corrosive atmospheric conditions.

With respect to any defective product during the warranty period, Tamarack Solar Products will, in its sole discretion, either (a) repair or replace such product (or defective part) free of charge or (b) refund the purchase price of the product. Such repair, replacement, or refund will not cause the warranty periods to be reset, will completely satisfy and discharge Tamarack Solar Products' liability and obligation with respect to this limited warranty, and will not create an expectation of warranty coverage in the future. A refurbished product may be used to repair or replace defective components. Transportation, installation, labor, or any other costs or losses associated with failure of warranty compliance, or product replacement or repair, are not covered by this limited warranty and are not reimbursable. If Tamarack Solar Products' warranty assessment reveals that a product is not defective, Tamarack Solar Products shall return the product (if such product was shipped to Tamarack Solar Products for the assessment) and the purchaser shall promptly reimburse Tamarack Solar Products for all reasonable costs incurred by Tamarack Solar Products in performing the assessment.

Tamarack Solar Products may request the purchaser to provide information known to the purchaser in respect of the alleged defect or warranty claim, including, as appropriate, photographs or video recordings of the alleged defect. Purchaser shall provide Tamarack Solar Products without undue delay with all additional information and cooperation (including access to facilities and premises) requested by Tamarack Solar Products in respect of any warranty claim to enable Tamarack Solar Products to assess each claim under this limited warranty.

This limited warranty shall commence on the date of shipment of the products and last for the following periods, depending on the products purchased.:

Flush Mount (FM) and Ground Mount (GM) products 25 years

Pole Mounts (TTP-A, UNI-PGRM, UNI-SP and UNI-SA products 10 years

Tamarack Solar Products further warrants that all products with finishes will be free of visible defects, peeling, and cracking for a period of five (5) years from the date of shipment (the "finish warranty"); provided, however, that no finish warranty shall apply to mill aluminum, or painted steel products.

Tamarack Solar Products may change the availability of this limited warranty at its discretion, but any changes will not be retroactive.

To report any defect or warranty claim or to obtain warranty services, purchaser may contact Tamarack Solar Products at (707) 222-6240 extension 556, email support@tamaracksolar.com or write to Tamarack Solar Products, 288 F Street, Arcata, CA 95521.

Limitation of liability

Except as set forth above, Tamarack Solar Products sells the products on an "as is" basis, which may not be free of errors or defects, and all express or implied representations and warranties, including any warranties of merchantability, fitness for a particular purpose, or arising from a course of dealing, course of performance, or trade practice, are hereby disclaimed. The remedies described above are purchaser's sole and exclusive remedies and Tamarack Solar Products' entire liability for any breach of this limited warranty. Tamarack Solar Products' liability shall under no circumstances exceed the actual amount paid by purchaser for the defective product, nor shall Tamarack Solar Products under any circumstances be liable for any consequential, incidental, or punitive damages or losses, whether direct or indirect, including without limitation, claims by purchaser for damages suffered by purchaser's customers or claims of third parties. Tamarack Solar Products shall not be responsible for delays or failures in its performance resulting from acts or omissions beyond its reasonable control, whatever the source or cause.