



TECHNICAL NOTE

TOPIC

JMTHY JMS-F: Alternative Mounting Method

PURPOSE

This notice provides instructions for mounting the JMS-F SunSpec Rapid Shutdown Device when the standard method of attaching the device's mounting bracket to a solar PV module using a bolt hole provided in the solar PV module frame is not possible.

APPLICABLE PRODUCTS

JMS-F SUNSPEC RAPID SHUTDOWN DEVICE

Type designation: JMS-F

SMA Part Number: 119814-00.01

BACKGROUND

The JMS-F SunSpec Rapid Shutdown Device is designed to mount directly to a solar PV module frame. The standard method for mounting uses a M4 bolt which passes through a bolt hole provided in the solar PV module frame. The standard mounting method is described in the installation manual which is available for download on the SMA America product website: <https://www.sma-america.com/products/sunspec-certified-rapid-shutdown-technology/jms-f-sunspec-rapid-shutdown-device.html>

Alternative Mounting Instructions

In the event that mounting the JMS-F SunSpec Rapid Shutdown Device to the solar PV module frame is not possible according to the standard bolt hole attachment method described in the installation manual, it is allowed to mount the JMS-F device to the flange of the solar PV module frame using the alternative technique described below. In order to securely mount the JMS-F device without the possibility of damaging the devices or the solar PV modules, the following equipment is needed:

- » (1) JMS-F SunSpec Rapid Shutdown Device
- » (1) M4-0.7 x 10 mm Stainless Steel Machine Screw
- » A driver capable of being adjusted to a torque setting of between 2.0 - 2.5 Nm (17.7 - 22.1 in.lb) of force

Device Placement

If mounting to a bolt hole in the solar PV module frame is not possible, please choose a placement for the JMS-F device on the solar PV module frame which avoids interfering with the solar PV mounting system. Do not mount the JMS-F device in such way that the drain holes of solar PV modules are blocked. Please also ensure that there is a minimum clearance of at least 38mm (1.5 inches) between the solar PV module and the roof surface.

Device Mounting

For best results, it is generally recommended to perform the following steps before attaching the solar PV module to the mounting system.

Alternative JMS-F Device Mounting Instructions

1. Orient the JMS-F device so that the JMTHY logo on the plastic cover is facing towards the backside of the solar PV module. See Figure 1 below.
2. Slide the mounting bracket over the flange on the solar PV module frame. Ensure that the two metal arms are not bent due to excessive force. The “teeth” on the metal arms provide the grounding bond between the JMS-F device and the solar PV module frame according to NEC Article 690.43.
3. Insert the M4 x 10mm machine bolt into the threaded hole on the JMS-F mounting bracket.
4. Screw the M4 x 10mm machine bolt until it is fully seated into the threaded hole on the JMS-F mounting bracket. Tighten to 2.0 ~ 2.5 Nm (17.7 ~ 22.1 in.lb).
5. Verify electrical continuity between the JMS-F metal mounting bracket and the solar PV module frame (recommended).
6. Connect the short (black) cable leads on the JMS-F device to the connectors on the solar PV module prior to connecting the long (red) cable leads to another JMS-F device (series string connection). Secure loose cables to solar PV module frame.

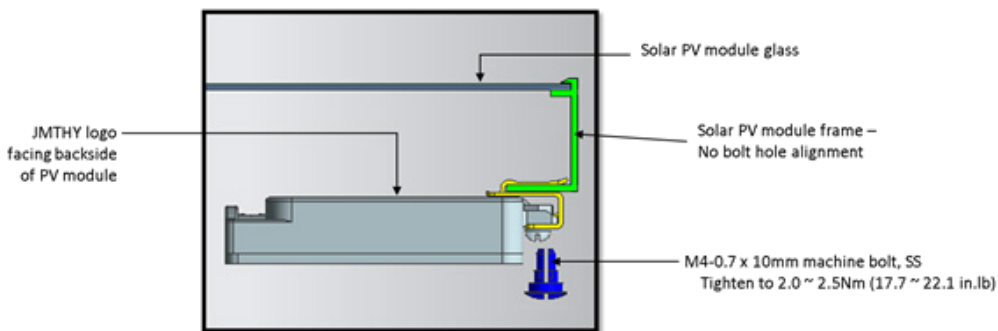

FIGURE 1

A simplified diagram showing the alternative mounting method described above



STATEMENT REGARDING GROUNDING

The grounding/bonding evaluation for the JMS-F was completed as part of the UL1741 certification. The metal arms on the mounting bracket contain "teeth" which cut into the anodization layer of the solar PV module frame when a compression force is applied using the alternative mounting instructions described above. These "teeth" create the grounding bond between the JMS-F device and the solar PV module frame according to NEC Article 690.43.

All solar PV module frames with JMS-F devices attached must be properly grounded in accordance with current National Electrical Code (NEC), or other required local, regional, or international regulations. A solar PV module with exposed conductive parts is considered to be in compliance with UL 1703 only when it is electrically grounded in accordance with the manufacturer's instructions and the requirements of the National Electrical Code.

Any grounding system/method, which is designed in accordance with relevant international and local standards and regulations, such as UL2703, UL1703, UL467, NEC Articles 250 and 690.43, etc. can be used for solar PV modules with JMS-F devices attached as long as the system is installed according to the manufacturer's instructions.

Proper grounding is achieved by bonding the solar PV module frame(s) and all metallic structural members together continuously using a suitable grounding conductor, NEC listed grounding device, or racking system that can be used for integrated grounding. For an adequate ground, the grounding hardware should penetrate any anodized layer. The grounding conductor must eventually make a connection to earth using a suitable earth ground electrode.

ADDITIONAL ASSISTANCE

For additional assistance in completing any of the instructions described above, contact SMA Service Line at 1-877-697-6283.

PHOTO APPENDIX

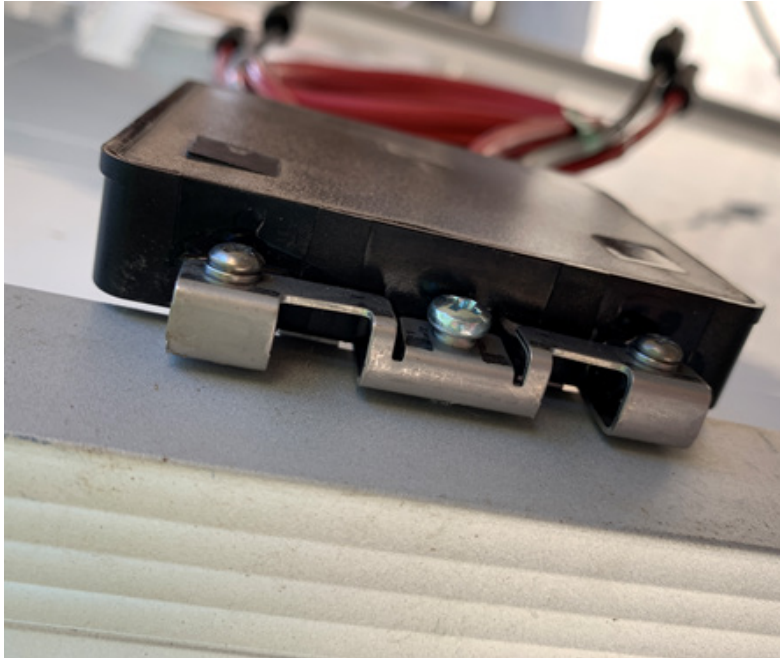

FIGURE 2
Correctly mounted JMS-F according to the instructions provided in this technical note



FIGURE 3
Correctly mounted JMS-F showing grounding "teeth" correctly engaging solar PV module frame