

ITEM NO.	DESCRIPTION	QTY.
1	QCLICK, 17MM, AL, MILL	1
2	RUBBER O-RING, 5MM ID X 2MM THK, BUNA-N	1
3	UNIVERSAL MID CLAMP, SUB-ASSY, V1.5, QRAIL, 40MM, 2 PIN, AL, MILL	1
4	CAP SCREW, SERRATED FLANGE, HEX HEAD, M6 X 1.0MM X 40MM, 1/2" HEAD, A2-70 SS	1

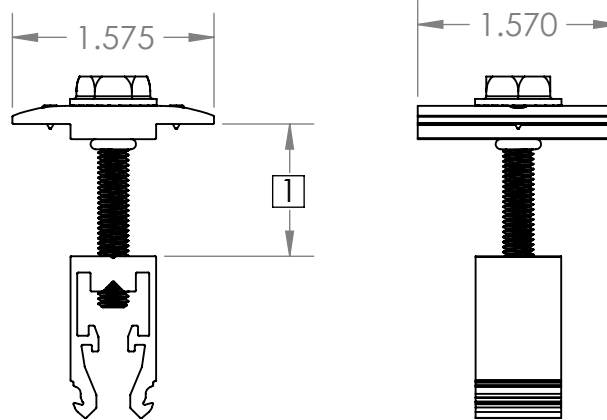
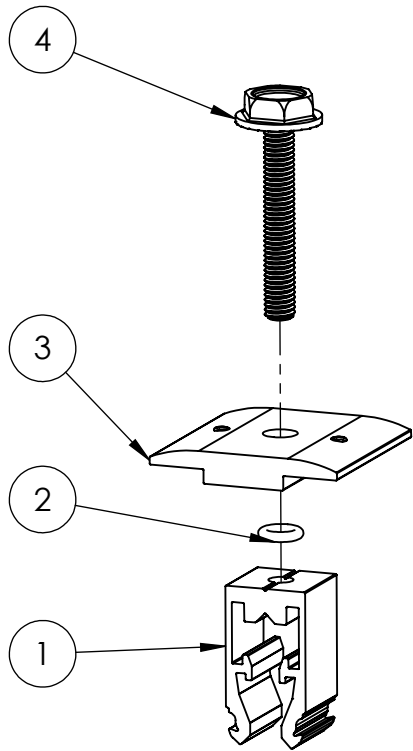

NOTES:

- 1 AVAILABLE IN TWO SIZE RANGES: 30-45 MM AND 38-50 MM
- 2. ALL VERSIONS AVAILABLE IN MILL FINISH AND BLACK FINISH

Quick Mount PV[®]

TITLE:
**QMR-UMC: UNIVERSAL MID CLAMP,
V1.5, 1/2" DRIVE, 2 PIN, QRAIL, W/
BONDING**

UNLESS OTHERWISE SPECIFIED: DIMENSIONS ARE IN INCHES TOLERANCES: FRACTIONAL ± 1/8 TWO PLACE DECIMAL ±.19 THREE PLACE DECIMAL ±.094	SIZE A	DRAWN BY: DFM	REV 1
	SCALE: 1:1.5	DATE: 9/18/2019	WEIGHT: 0.10
		SHEET 1 OF 1	