

# MPPT Disconnect RS

## Installation and Owner's Guide

990-91313B

September 2023



## Legal Information

The Schneider Electric brand and any trademarks of Schneider Electric SE and its subsidiaries referred to in this guide are the property of Schneider Electric SE or its subsidiaries. All other brands may be trademarks of their respective owners.

This guide and its content are protected under applicable copyright laws and furnished for informational use only. No part of this guide may be reproduced or transmitted in any form or by any means (electronic, mechanical, photocopying, recording, or otherwise), for any purpose, without the prior written permission of Schneider Electric.

Schneider Electric does not grant any right or license for commercial use of the guide or its content, except for a non-exclusive and personal license to consult it on an "as is" basis. Schneider Electric products and equipment should be installed, operated, serviced, and maintained only by qualified personnel.

As standards, specifications, and designs change from time to time, information contained in this guide may be subject to change without notice.

To the extent permitted by applicable law, no responsibility or liability is assumed by Schneider Electric and its subsidiaries for any errors or omissions in the informational content of this material or consequences arising out of or resulting from the use of the information contained herein.

If this manual is in any language other than English, although steps have been taken to maintain the accuracy of the translation, the accuracy cannot be guaranteed. Approved content is contained with the English language version which is posted at <http://solar.se.com/>.

## Contact Information

For country-specific details, please contact your local Schneider Electric Sales Representative or visit the Schneider Electric website at: <http://solar.se.com/>

## Information About Your System

As soon as you open your product, inspect the contents and record the following information and be sure to keep your proof of purchase. If any damage is found, contact customer support.

Serial Number \_\_\_\_\_

Purchased From \_\_\_\_\_

Product Number \_\_\_\_\_

Purchase Date \_\_\_\_\_

**Document Number:** 990-91313B

**Date:** September 2023

**Model Name:**

MPPT Disconnect RS

**Product Part Number:**

865-1036

# Safety Information

## Important Information

Read these instructions carefully and look at the equipment to become familiar with the device before trying to install, operate, service or maintain it. The following special messages may appear throughout this documentation or on the equipment to warn of potential hazards or to call attention to information that clarifies or simplifies a procedure.

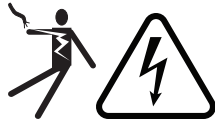

The addition of either symbol to a “Danger” or “Warning” safety label indicates that an electrical hazard exists which will result in personal injury if the instructions are not followed.



This is the safety alert symbol. It is used to alert you to potential personal injury hazards. Obey all safety messages that follow this symbol to avoid possible injury or death.

### **DANGER**

**DANGER** indicates a hazardous situation which, if not avoided, **will result in** death or serious injury.

### **WARNING**

**WARNING** indicates a hazardous situation which, if not avoided, **could result in** death or serious injury.

### **CAUTION**

**CAUTION** indicates a hazardous situation which, if not avoided, **could result in** minor or moderate injury.

### **NOTICE**

**NOTICE** is used to address practices not related to physical injury.

## Please Note

Electrical equipment should be installed, operated, serviced, and maintained only by qualified personnel. No responsibility is assumed by Schneider Electric for any consequences arising out of the use of this material.

A qualified person is one who has skills and knowledge related to the construction, installation, and operation of electrical equipment and has received safety training to recognize and avoid the hazards involved. For more information, see *Audience*.

# Audience

This manual is intended for use by qualified personnel installing a system involving Schneider Electric MPPT Disconnect RS.

The qualified personnel have training, knowledge, and experience in:

- Installing electrical equipment and PV and DC input systems (up to 600 V).
- Applying all applicable installation codes.
- Analyzing and reducing the hazards involved in performing electrical work.
- Selecting and using Personal Protective Equipment (PPE).

Only qualified personnel should perform the installation and commissioning of the MPPT Disconnect RS.

# About

## Purpose

The purpose of this Guide is to provide explanations and procedures for installing, configuring, operating, and troubleshooting the MPPT Disconnect RS.

## Scope

This Guide provides safety guidelines, detailed planning and setup information, procedures for installing the unit, as well as information about operating and troubleshooting. It does not provide details about particular brands of photovoltaic (PV) panels. Consult individual PV manufacturers for more information.

## Abbreviations and Acronyms

AFD	Arc Fault Detector
CEC	Canadian Electric Code
CSA	Canadian Standards Association
DC	Direct Current
FCC	Federal Communications Commission
$I_{MP}$	Current at maximum power per STC
$I_{SC}$	Short circuit current rating of an PV panel under STC
LED	Light Emitting Diode
MPP	Maximum Power Point
MPPT	Maximum Power Point Tracking
MSDS	Material Safety Data Sheet
NFPA	National Fire Protection Association
PDP	Conext Power Distribution Panel
PV	Photovoltaic
RSD	Rapid Shutdown
STC	Standard Test Conditions specific to photovoltaic panels (1000 W/m <sup>2</sup> , light spectrum AM 1.5 and 25°C); panel nameplate ratings are based on STC and may be exceeded under other conditions.
UL	Underwriters Laboratories
VAC	Volts AC
VDC	Volts DC
$V_{MP}$	Voltage at maximum power per STC
$V_{OC}$	Open circuit voltage rating of a PV panel under STC

# Related Information

For more information about Schneider Electric as well as its products and services, visit <http://solar.se.com/>.

## Safety Information

**Before installing or using this device, read all instructions and cautionary markings in this guide, on the unit, the batteries, PV array, and all other equipment in the system.**

- The manufacturer recommends that all wiring be done by a certified technician or electrician to ensure adherence to the local and national electrical codes applicable in your jurisdiction.
- This product is designed for indoor mounting only. Do not expose this unit to direct sunlight, rain, snow, heat sources, or liquids of any type.
- To avoid a risk of fire and electric shock, make sure that existing wiring is in good condition and that wire is not undersized. Do not operate this equipment with damaged or substandard wiring.
- Do not operate this equipment if it has been damaged in any way.
- To reduce the chance of short-circuits, always use insulated tools when installing or working with this equipment. Do not leave tools inside the unit.
- Remove personal metal items such as rings, bracelets, necklaces, and watches when working with electrical equipment.

### **DANGER**

#### **HAZARD OF ELECTRIC SHOCK, EXPLOSION, ARC FLASH, AND FIRE**

- Apply appropriate personal protective equipment (PPE) and follow safe electrical work practices. See NFPA 70E or CSA Z462.
- This equipment must only be installed by qualified electrical personnel.
- Never energize the MPPT Disconnect RS with covers removed.
- Energized from multiple sources. Before removing covers identify all sources, de-energize, lock-out, and tag-out and wait 2 minutes for circuits to discharge.
- Always use a properly rated voltage sensing device to confirm all circuits are de-energized.
- Do not install/store the MPPT Disconnect RS near flammable material.
- Always verify correct polarity of the PV and Battery terminal connections.
- Ensure that Control and PV cables are properly inserted in the respective terminal blocks.
- Follow all Schneider Electric and Battery manufacturer guidelines for battery protection.
- Do not attempt to replace components.

**Failure to follow these instructions will result in death or serious injury.**

 **DANGER**
**HAZARD OF ELECTRIC SHOCK, EXPLOSION, ARC FLASH, AND FIRE**

- Disconnect positive and negative PV conductors before servicing. PV conductors are to be treated as Hazardous Live and must be disconnected.
- Normally GROUNDED conductors may be UNGROUNDED and ENERGIZED when a GROUND FAULT is indicated on the front panel. Must be serviced by qualified personnel.

**Failure to follow these instructions will result in death or serious injury.**

 **WARNING**
**HAZARD OF ELECTRIC SHOCK, EXPLOSION, ARC FLASH, AND FIRE**

- This photovoltaic rapid shutdown system (PVRSS) does not perform all of the functions of a complete photovoltaic rapid shutdown system (PVRSS). This PVRSS must be installed with other equipment to form a complete PVRSS that meets the requirements of NEC (NFPA 70) section 690.12 for controlled conductors outside the array.
- Other equipment installed in or on this PV system may adversely affect the operation of the PVRSS.
- It is the responsibility of the installer to ensure that the completed PV system meets the rapid shut down functional requirements.
- This equipment must be installed according to the manufacturer's installation instructions.

**Failure to follow these instructions can result in death, serious injury, or equipment damage.**

 **WARNING**
**LIMITATIONS OF USE**

Do not use this equipment with life support equipment or other medical equipment or devices.

**Failure to follow these instructions can result in death, serious injury, or equipment damage.**

 **WARNING**
**HAZARD OF INJURY OR EQUIPMENT DAMAGE**

- The installer must provide signage that complies with section 690.56(C) of the NEC (NFPA 70).

**Failure to follow these instructions can result in death, serious injury, or equipment damage.**



**NOTICE****LIGHTNING PROTECTION**

To help protect this equipment's insulation and conductors from damage due to a sudden over-voltage surge such as lightning strikes, install a DC-rated lightning arrester on the DC input line.

**Failure to follow these instructions can result in equipment damage.**

## Battery Safety Information

For full installation instructions and safety information, see the documentation provided with the batteries. Consult the MSDS for the batteries for first aid procedures, emergency procedures, and clean-up instructions.

## FCC Information to the User

This MPPT Disconnect RS has been tested and found to comply with the limits for a Class B digital device, pursuant to part 15 of the FCC Rules and Industry Canada ICES-003. These limits are designed to provide reasonable protection against harmful interference when the charge controller is operated in a residential environment. This MPPT Disconnect RS generates, uses, and can radiate radio frequency energy and, if not installed and used in accordance with the installation and operation guides, could cause harmful radio frequency interference with radio communications. However, there is no guarantee that interference will not occur in a particular installation. If the charge controller does cause harmful interference with radio or television reception, which can be determined by turning the charge controller off and on, try to correct the interference by one or more of the following measures:

- Reorient or relocate the receiving antenna.
- Increase the separation between the charge controller and the receiver.
- Connect the charge controller to a different circuit from that to which the receiver is connected.
- Consult the dealer or an experienced radio or TV technician for help.

**⚠ CAUTION****RISK OF INJURY**

Unauthorized changes or modifications to the equipment could void the user's authority to operate the equipment.

**Failure to follow these instructions can result in injury or equipment damage.**

## Personal Protective Equipment

To perform this work, qualified personnel must be equipped with appropriate personal protective equipment including the following:

- Electrical rated rubber insulating gloves with leather protectors (optional liners)
- Safety glasses or goggles
- Arc-rated long sleeve shirt and arc-rated pants or arc-rated coverall or arc-rated flash suit
- Hearing protection
- Electrically rated footwear
- Arc-rated face shield with arc-rated hard hat and hood or arc flash suit hood
- LOTO locks and tags
- Multimeter or voltage tester with the following minimum ratings:  
600 VDC

Check local safety regulations for other requirements.

# Contents

Legal Information .....	1
Contact Information .....	1
Information About Your System .....	1
<b>Safety Information .....</b>	<b>2</b>
<b>Audience .....</b>	<b>3</b>
<b>About .....</b>	<b>4</b>
Purpose .....	4
Scope .....	4
Abbreviations and Acronyms .....	4
Related Information .....	5
Safety Information .....	6
Battery Safety Information .....	8
FCC Information to the User .....	8
Personal Protective Equipment .....	9
<b>Introduction .....</b>	<b>1</b>
Introduction .....	2
Rapid Shutdown .....	2
Arc Fault Detection .....	2
PV Equipment Disconnection .....	2
MPPT Disconnect RS Physical Features .....	3
<b>Installation .....</b>	<b>5</b>
Lock-Out and Tag-Out (LOTO) .....	6
Pre-Installation .....	7
Planning the Installation .....	7
Installation Tools and Materials .....	7
Inspection .....	8
Package Contents .....	9
Location .....	9
Clearance Requirements .....	10
Removing the Front Cover .....	11
Mounting the MPPT Disconnect RS .....	11
Knockout Selection .....	12
Mounting the RS Initiator Switch .....	13
Mounting Tigo® Devices .....	13
Wiring .....	14
Requirements .....	14
Connecting the PV Input to MPPT Disconnect RS and charge controller .....	18
Network Installation .....	22
Reinstall the Front Cover and DC Disconnect Switch .....	25
<b>Commissioning .....</b>	<b>26</b>
Pre-Commissioning Inspections .....	27
Start-Up Procedure .....	27

Operation .....	30
Front Panel UI .....	31
Arc Fault .....	31
Arc Fault Detection .....	31
Resetting a Tripped AFD Device .....	32
Rapid Shutdown .....	32
Rapid Shutdown System Overview .....	33
Rapid Shutdown Self-Test .....	33
Clearing an RSD Fault .....	34
DC Disconnect Switch .....	34
RS Initiator switch .....	35
MPPT Disconnect RS Control Power Supply .....	35
Communication .....	35
Xanbus Connections .....	36
Troubleshooting .....	38
Troubleshooting .....	39
Specifications .....	42
Specifications .....	43
Torque Values .....	44

# Figures

Figure 1 MPPT Disconnect RS features .....	3
Figure 2 LOTO .....	6
Figure 3 Package contents .....	9
Figure 6 Wall mounting .....	12
Figure 8 Connection to two Conext MPPT 80 600 Solar Charge Controllers .....	15
Figure 9 Connection to a single Conext MPPT 80 600 Solar Charge Controller .....	15
Figure 10 Connection to a Conext MPPT 60 150 Solar Charge Controller .....	16
Figure 11 Ground/Earth conductor .....	19
Figure 12 PV wire preparation .....	19
Figure 13 Spring cage connection .....	20
Figure 14 MPPT Disconnect RS connections .....	20
Figure 15 Battery wire preparation .....	21
Figure 16 RS Initiator switch wire preparation .....	21
Figure 17 RS Initiator switch connections .....	22
Figure 18 Network terminator .....	23
Figure 19 Network .....	23
Figure 20 Daisy chain layout .....	24
Figure 22 AFD self test error .....	32
Figure 23 AFD fault .....	32
Figure 24 RSD event .....	33
Figure 25 DC Disconnect switch .....	34
Figure 26 RS Initiator switch .....	35

# Tables

Table 1 Wire distance and size .....	18
Table 2 Ground cable specifications .....	19
Table 3 Front panel UI .....	31
Table 4 RJ-45 pin details .....	36
Table 5 Troubleshooting .....	39
Table 6 MPPT Disconnect RS Specifications .....	43
Table 7 Fastener torque values .....	44

# 1 Introduction

## What's in This Chapter?

<b>Introduction</b> .....	<b>2</b>
Rapid Shutdown .....	2
Arc Fault Detection .....	2
PV Equipment Disconnection .....	2
<b>MPPT Disconnect RS Physical Features</b> .....	<b>3</b>

## Introduction

The MPPT Disconnect RS is an accessory for the Conext MPPT 60 150, Conext MPPT 80 600, and Conext MPPT 100 600 charge controllers (charge controllers). It provides PV disconnection means, Rapid Shutdown, and Arc Fault detection. These features are described in more detail below.

## Rapid Shutdown

The MPPT Disconnect RS is qualified as PV rapid shutdown system (PVRSS). It includes a power line communication (PLC) rapid shutdown transmitter. It is certified for use with only the Tigo® devices specified below for PV rapid shutdown systems to meet NEC 2017 (690.12). Rapid shutdown functionality is achieved only when the PV modules are equipped with compatible models of Tigo TS4-F, installed according to local codes and standards.

### Compatible Tigo devices:

- TS4-F
- TS4-R-F
- TS4-A-F
- TS4-A-2F

MPPT Disconnect RS is qualified as a PVRSS when used in conjunction with TIGO receivers, charge controller and RS Switch. MPPT Disconnect RS as a standalone unit can be a PVRSE.

When initiated, rapid shutdown reduces the voltage of the photovoltaic (PV) circuit(s) to less than 30 V within 30 seconds, disconnecting them from the charge controller, and turning off the Conext MPPT Solar Charge Controllers through daisy chain connected Xanbus communication. The MPPT Disconnect RS is compatible with the Conext MPPT 80 600 and Conext MPPT 60 150 charge controller. Up to two Conext MPPT 80 600 charge controllers, or one Conext MPPT 60 150 charge controller can be connected to each MPPT Disconnect RS.

## Arc Fault Detection

The MPPT Disconnect RS complies with NEC 690.11 "Arc-Fault Circuit Protection (Direct Current)", and includes an Arc Fault Detector. The MPPT Disconnect RS, when used in conjunction with the Conext MPPT 60 150 and Conext MPPT 80 600 charge controllers, detects and interrupts arc faults and complies with UL1699B.

## PV Equipment Disconnection

The MPPT Disconnect RS includes a 4-pole 32 A disconnect, which is used for disconnection of both the positive and negative leg of the PV inputs, as required in NEC 2017 (690.15). The MPPT Disconnect RS has two PV input channels.



# MPPT Disconnect RS Physical Features

Figure 1 MPPT Disconnect RS features

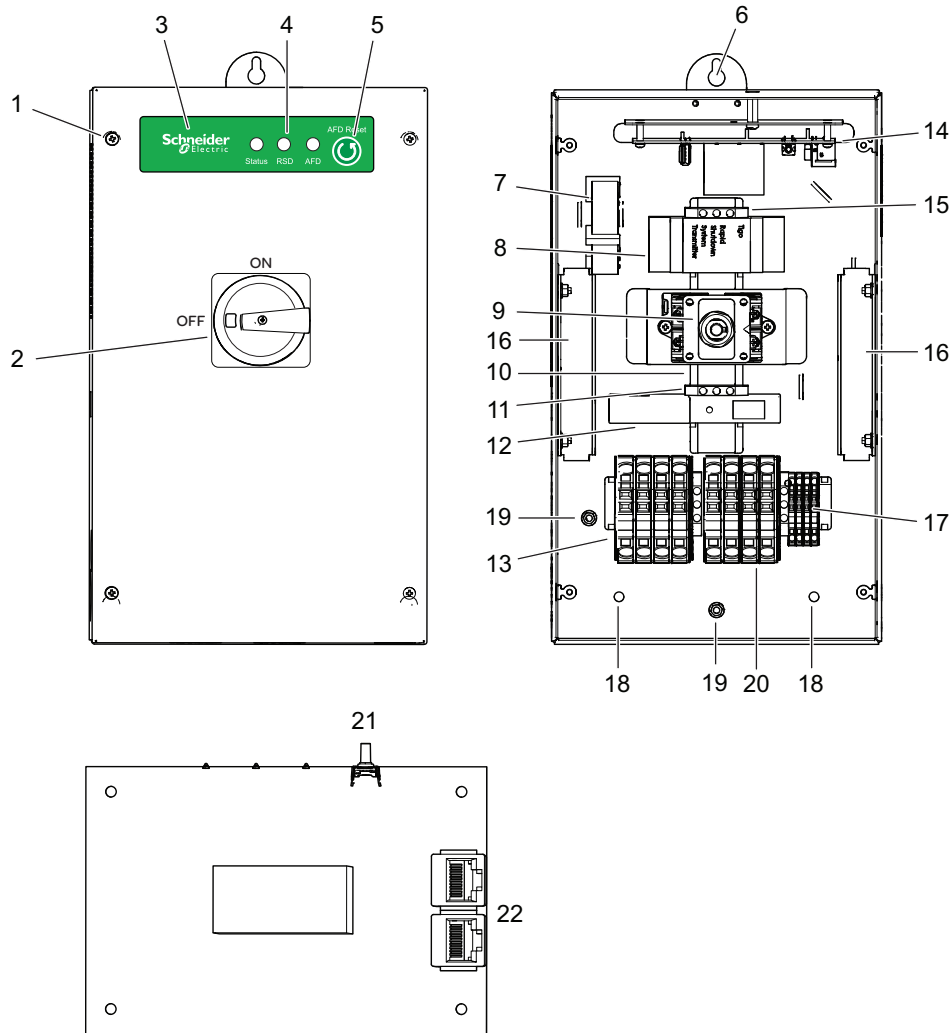

1	Top cover screws	12	AFD module
2	DC Disconnect switch	13	PV input terminal connectors
3	User interface panel	14	Control and Communication board (see details #21- 22)
4	Diagnostic LEDs	15	Stopper terminal
5	AFD Reset button	16	Cable tray/barrier
6	Top mounting hole position	17	Terminal block for battery and RS Initiator switch connections
7	RSD transmitter core	18	Bottom mounting hole positions
8	RSD Transmitter	19	Earth terminal stud
9	DC Disconnect switch (internal)	20	PV output terminal connectors
10	DIN rail	21	AFD reset switch
11	Stopper terminal	22	RJ45 connectors for Xanbus communication and network terminator



## 2 Installation

### What's in This Chapter?

<b>Lock-Out and Tag-Out (LOTO)</b> .....	<b>6</b>
<b>Pre-Installation</b> .....	<b>7</b>
Planning the Installation .....	7
Installation Tools and Materials .....	7
Inspection .....	8
Package Contents .....	9
Location .....	9
Clearance Requirements .....	10
Removing the Front Cover .....	11
Mounting the MPPT Disconnect RS .....	11
Knockout Selection .....	12
Mounting the RS Initiator Switch .....	13
Mounting Tigo® Devices .....	13
<b>Wiring</b> .....	<b>14</b>
Requirements .....	14
Connecting the PV Input to MPPT Disconnect RS and charge controller .....	18
Network Installation .....	22
Reinstall the Front Cover and DC Disconnect Switch .....	25

## Lock-Out and Tag-Out (LOTO)

Lock-out refers to the practice of preventing de-energized circuits from being reenergized by putting locks on the disconnecting devices, holding them open. Tag-out refers to the practice of attaching a tag to the disconnect-device locks warning others not to operate the disconnect device and containing information relating to the lock-out, such as the person responsible, the reason, and the date and time. Combined these two practices are called the lock-out and tag-out (LOTO) procedure.

⚡ ⚠ **DANGER**

**HAZARD OF ELECTRIC SHOCK, EXPLOSION, ARC FLASH, AND FIRE**

- Apply appropriate personal protective equipment (PPE) and follow safe electrical work practices. See NFPA 70E or CSA Z462.
- This equipment must only be installed by qualified electrical personnel.
- Never energize the MPPT Disconnect RS with covers removed.
- Energized from multiple sources. Before removing covers identify all sources, de-energize, lock-out, and tag-out and wait 2 minutes for circuits to discharge.
- Always use a properly rated voltage sensing device to confirm all circuits are de-energized.
- Do not install/store the MPPT Disconnect RS near flammable material.
- Always verify correct polarity of the PV and Battery terminal connections.
- Ensure that Control and PV cables are properly inserted in the respective terminal blocks.
- Follow all Schneider Electric and Battery manufacturer guidelines for battery protection.
- Do not attempt to replace components.

**Failure to follow these instructions will result in death or serious injury.**

Figure 2 LOTO

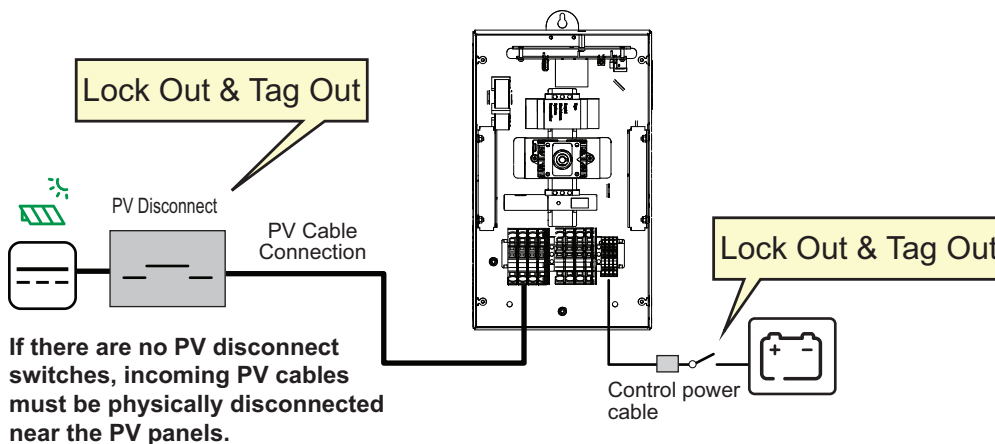

**LOTO procedure:**

1. Turn the MPPT Disconnect RS DC Disconnect switch to the OFF position.
2. Identify any disconnect device upstream from the MPPT Disconnect RS.
3. If installed, lock-out and tag out the external PV disconnect device.
4. If there is no external PV disconnect device, disconnect all incoming PV cables near the PV panels, following the PV panel manufacturer's safety and procedural instructions.
5. Verify that the battery disconnect switches are turned off, locked out and tagged out.
6. Wait ten minutes for the circuits in the MPPT Disconnect RS to discharge.
7. Verify that the MPPT Disconnect RS is de-energized before performing work.

## Pre-Installation

Before installing the MPPT Disconnect RS, read all instructions and cautionary markings in this guide.

**NOTE:** Obtain all necessary permits prior to starting the installation. **Installations must meet all local codes and standards.** Installation of this equipment should only be performed by qualified personnel.

## Planning the Installation

- Read this entire chapter before beginning the installation. It is important to plan the installation from beginning to end.
- Assemble all tools and materials needed for the installation.

## Installation Tools and Materials

To complete the installation, you will need the following tools:

- Complete set of electrical hand tools, including screwdriver sets with insulated handles (flat-head and Phillips). **NOTE:** Use only for mounting.
- Screwdriver sets (flat-head and Phillips)
- Wrench set
- Power drill (use only for mounting)
- Calibrated torque wrench set (Nm or lb-ft), suitable for torque values ranging from 0.5–3.1 Nm (0.4–2.3 lb-ft)
- Wire stripper
- M4 screws for mounting the RSD Initiator switch
- Level

Depending on your installation, additional hardware may be required. The following items are not included with the MPPT Disconnect RS:

- RS Initiator switch (part number 865-1039)
- Compatible models of Tigo® TS4-F (installed according to the applicable Tigo installation manual)
- Grounding wire: #6 AWG to #14 AWG (13.5 to 2.5 mm<sup>2</sup>)
- Suitably rated cable to connect the RS Initiator switch to the MPPT Disconnect RS
- Suitably rated cable to connect from the MPPT Disconnect RS's PV output to the Conext MPPT charge controller
- RJ45 Xanbus communication cable to connect to the charge controller
- Appropriate materials and hardware for additional wall-mount support

## Inspection

Before unpacking the MPPT Disconnect RS, check the outer packaging materials for damage. If any damage is found, contact your supplier.

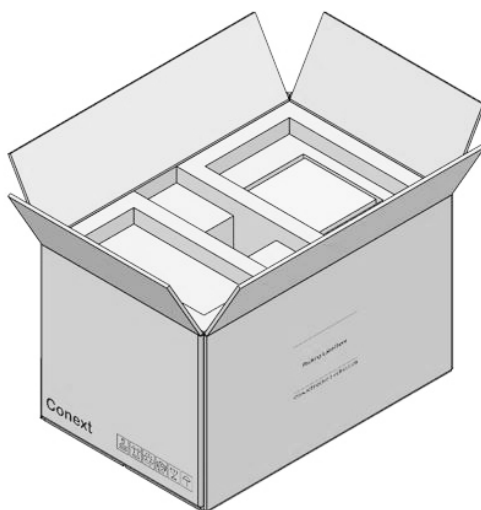

## Package Contents

The following materials are shipped with the MPPT Disconnect RS:

Figure 3 Package contents

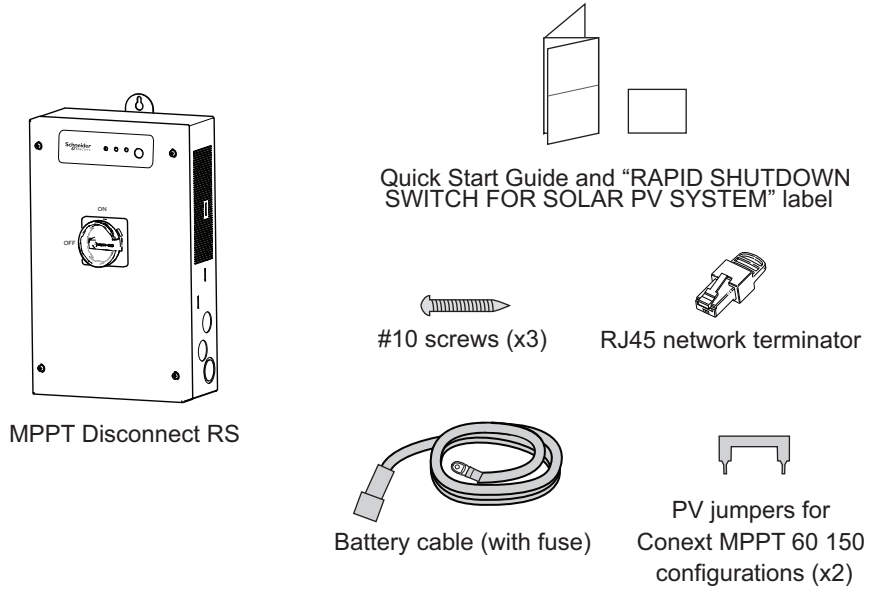

**NOTE:** The RS Initiator switch (part number 865-1039) is not included and must be ordered separately.

## Location

The MPPT Disconnect RS is certified for dry, indoor (heated or unheated) installations only.

Move any electronic equipment susceptible to radio frequency and electromagnetic interference as far away from the MPPT Disconnect RS as possible.

## Fire safety

**⚠ ⚠ WARNING**

**HAZARD OF ELECTRIC SHOCK, EXPLOSION AND FIRE**

This equipment is not ignition protected. Do not install this product in locations that require ignition-protected equipment. This includes any confined space containing lead acid batteries, or flammable chemicals such as, natural gas (NG), liquid petroleum gas (LPG) or gasoline (Benzine/Petrol).

- Do not install in a confined space with machinery powered by flammable chemicals, or storage tanks, fittings, or other connections between components of fuel or flammable chemical systems. Keep flammable materials a minimum distance of 10 meters (33 feet) from the top surface and 30 cm (12 in) from either side surface and the front of the MPPT Disconnect RS.
- The MPPT Disconnect RS must be mounted vertically and installed indoors in a dry, protected location away from flammable materials, sources of high temperature, moisture, vibration, direct sunlight, dust, and wind-blown debris.

**Failure to follow these instructions can result in death, serious injury, or equipment damage.**

## Clearance Requirements

For optimal operation, ensure there is adequate clearance around the MPPT Disconnect RS, as shown below. If clearances are reduced below these minimums, rated performance may not be achieved.

Location	Minimum Clearance
Above	6 in (152 mm)
In front	Sufficient room to allow for the following: <ul style="list-style-type: none"> <li>▪ To allow easy access to view the LEDs</li> <li>▪ To allow access the AFD Reset switch</li> <li>▪ To perform maintenance</li> </ul>
Sides	No clearance requirement

Figure 4 Clearance requirements for a MPPT Disconnect RS

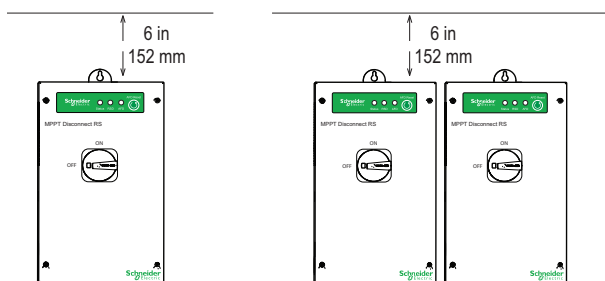



## Removing the Front Cover

Before mounting, verify that the MPPT Disconnect RS's DC Disconnect switch is in the OFF position.

To access the mounting holes and wiring terminals, the front cover must be removed.

### To remove the front cover:

1. Remove the small screw from the front of the DC Disconnect switch and then lift the switch knob off.
2. Loosen the plastic nut that was under the DC Disconnect switch.
3. Remove the four Phillips M4 x 25 mm screws on the front cover of the unit. Save for later reinstallation.

Figure 5 DC Disconnect switch and front cover removal

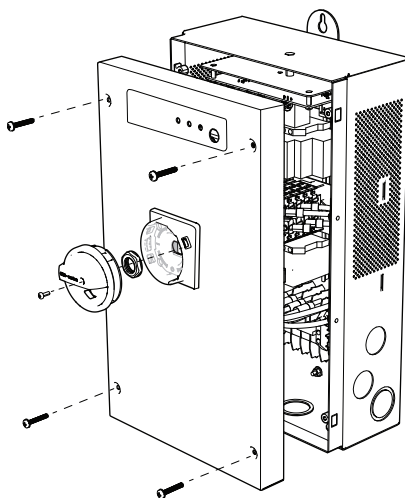

## Mounting the MPPT Disconnect RS

The MPPT Disconnect RS must be vertically mounted using three #10 × 1 in Phillips head screws.

### To mount the MPPT Disconnect RS:

1. Remove the front cover (see *Removing the Front Cover*).
2. Mark the location for the keyhole slot on the wall.
3. Mark the location for the bottom mounting screws on the wall.
4. Pre-drill holes into studs for the three mounting screws.
5. Install the top mounting screw in the location marked. Leave the screw head backed out approximately  $\frac{1}{4}$  in (6 mm). See *Figure 6*.
6. Place the MPPT Disconnect RS over the screw and pull it down so that the screw is in the keyhole slot.
7. Insert two screws through the two mounting holes provided at the bottom of the MPPT Disconnect RS to secure the unit to the wall. Torque to 3.1 Nm (2.3 ft-lb).

Figure 6 Wall mounting

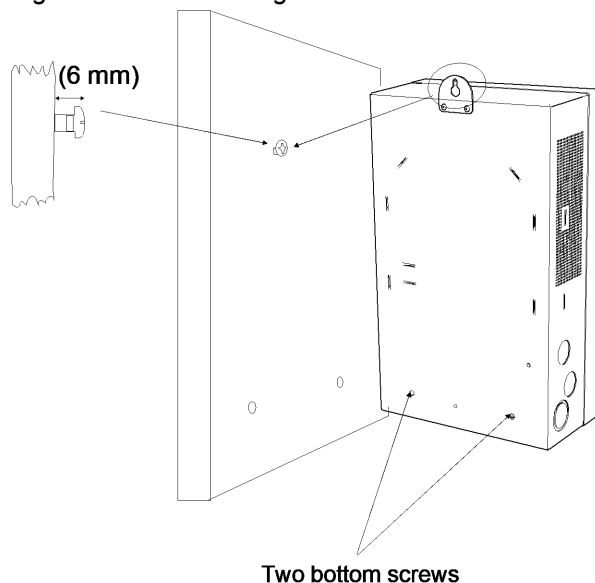

**NOTE:** If not attached to studs, you will need to provide adequate support for the MPPT Disconnect RS. For example, a sheet of plywood can be attached to the wall, and the MPPT Disconnect RS can then be attached to the plywood.

## Knockout Selection

Dual and single knockouts are provided for routing battery, PV array, and network cables into the MPPT Disconnect RS. Remove your choice of knockouts from the chassis. Ensure that no debris remains inside the chassis. Insert appropriately-sized conduit bushings into each conduit hole.

**NOTE:** Do not drill, cut, or punch holes into the MPPT Disconnect RS. Use only the knockouts provided for conduit entry.

The figure below shows the available knockouts. The knockouts on the side are aligned to the charge controller knockouts.

Figure 7 Available knockouts on the MPPT Disconnect RS

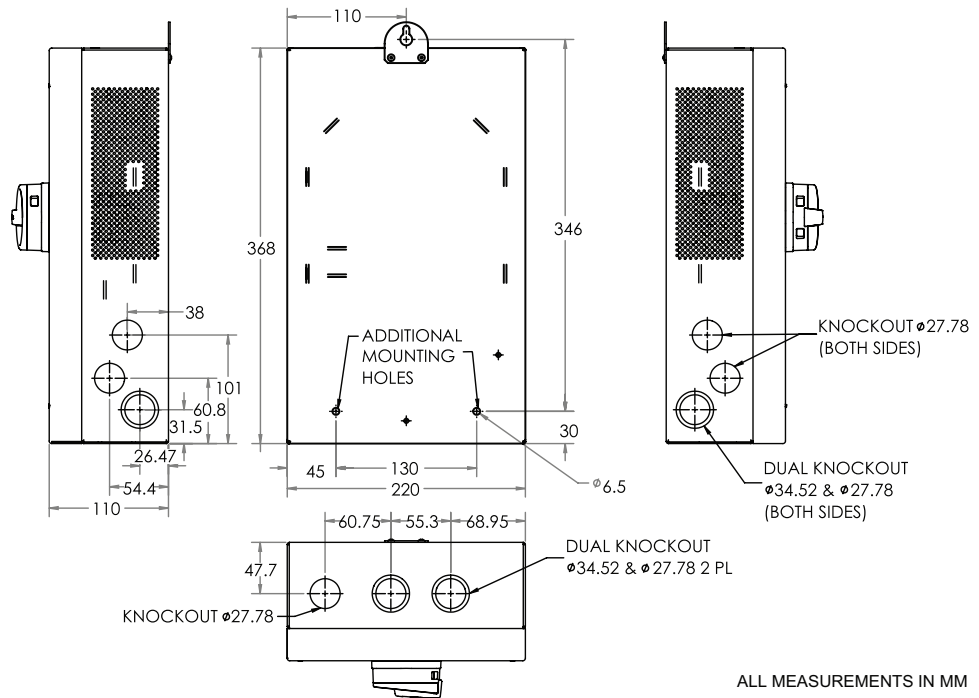

## Mounting the RS Initiator Switch

**Important:** The RS Initiator switch (part number 865-1039) must be installed in an accessible location, and the label (part number 885-91753) must be fixed within 1 meter (3 ft) of the RS Initiator switch assembly. For more information, see section 690.12 (C) of NEC 2017.

**NOTE:** RS Initiator switch is not included with the MPPT Disconnect RS and must be ordered separately.

For other mounting instructions, see the product manual for the RS Initiator switch.

## Mounting Tigo® Devices

**Important:** The Rapid Shutdown functionality is achieved only when the PV modules are equipped with compatible models of Tigo® TS4-F installed according to local codes and standards. For a list of compatible receivers, see *Rapid Shutdown on page 2* or *Specifications on page 43*.

For mounting instructions, see the applicable Tigo installation manual.

## Wiring

**Important:** Installations must meet all local electrical codes. This equipment should only be installed by a qualified electrician or a Certified Renewable Energy System Installer.

### **WARNING**

#### **ELECTRICAL SHOCK HAZARD**

Isolate positive and negative PV and battery circuits before wiring.

**Failure to follow these instructions can result in death, serious injury, or equipment damage.**

## Requirements

### MPPT Disconnect RS Terminal Connector Locations

Terminal connectors for PV wiring are located inside the wiring compartment. The labels below the DC wiring terminals and inside the wiring compartment identify all connection points, as shown below.

### **WARNING**

#### **HAZARD OF ELECTRIC SHOCK OR EQUIPMENT DAMAGE**

If a replacement battery fuse is needed, use Littelfuse® part number 0326002.MXP rated 125Vdc, 2A or equivalent.

**Failure to follow these instructions can result in death, serious injury, or equipment damage.**

Figure 8 Connection to two Conext MPPT 80 600 Solar Charge Controllers

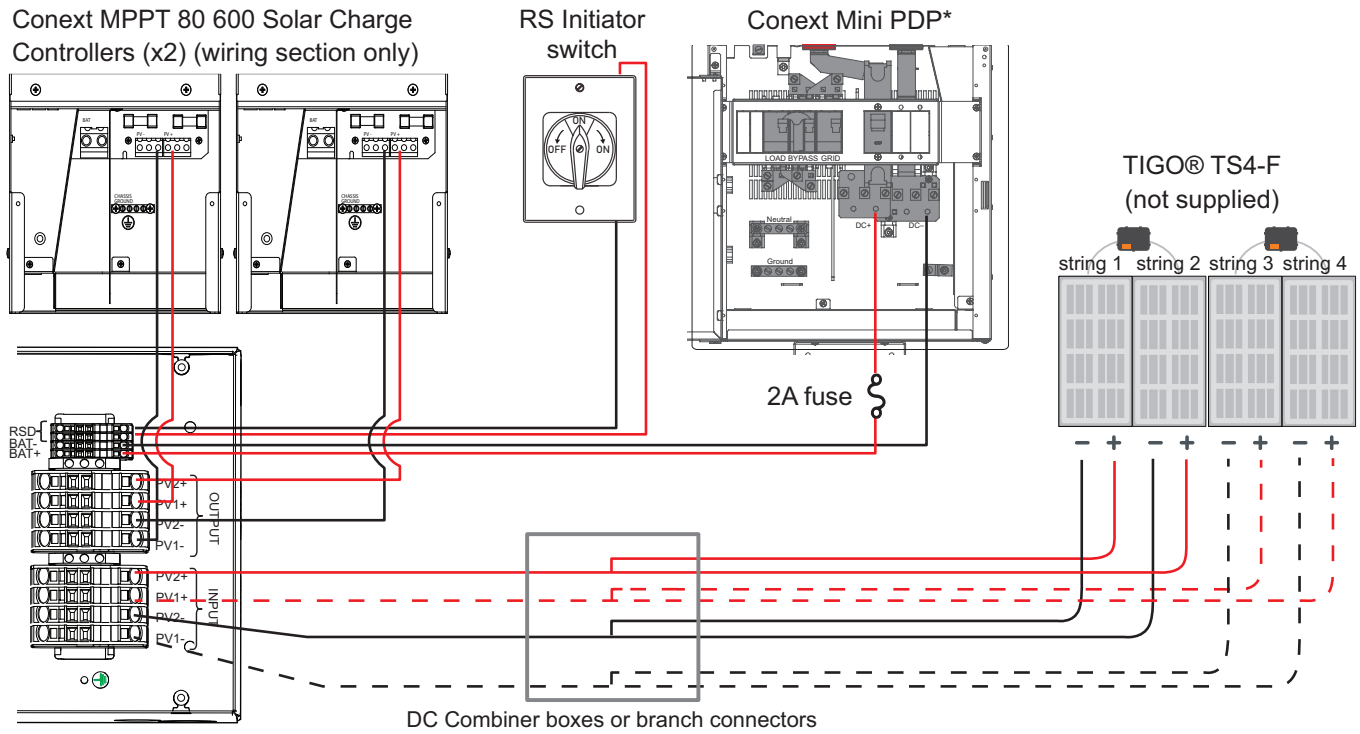
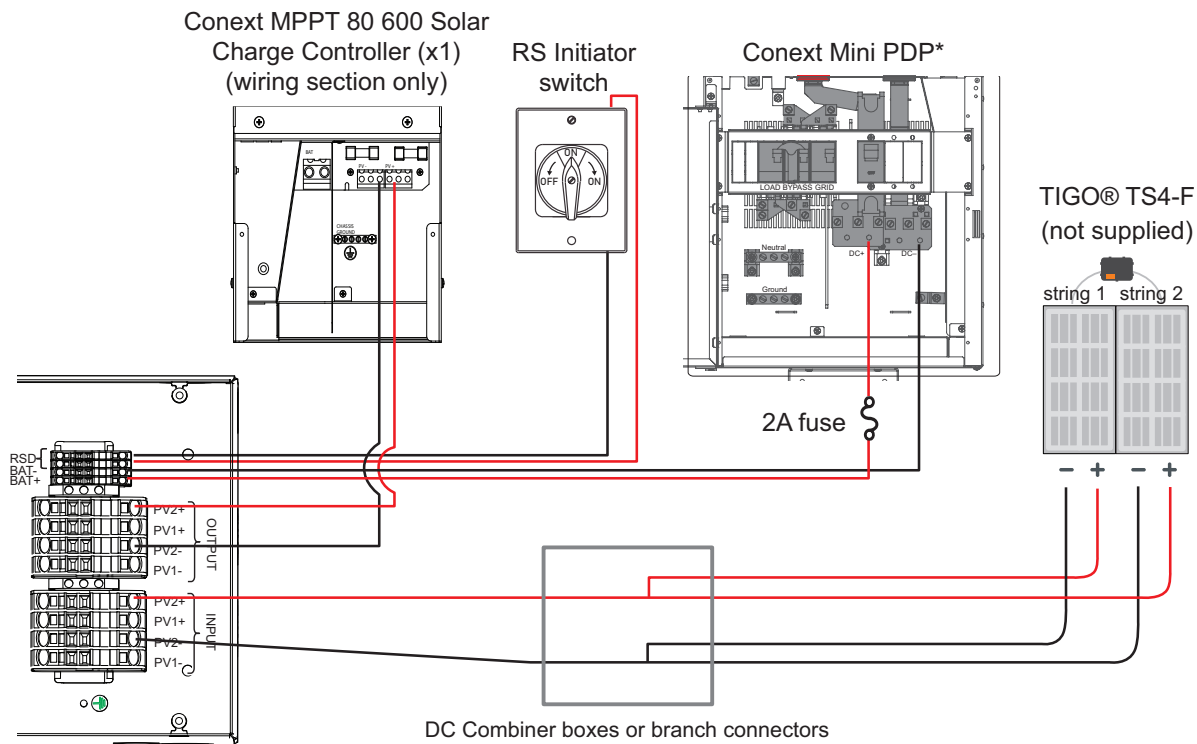
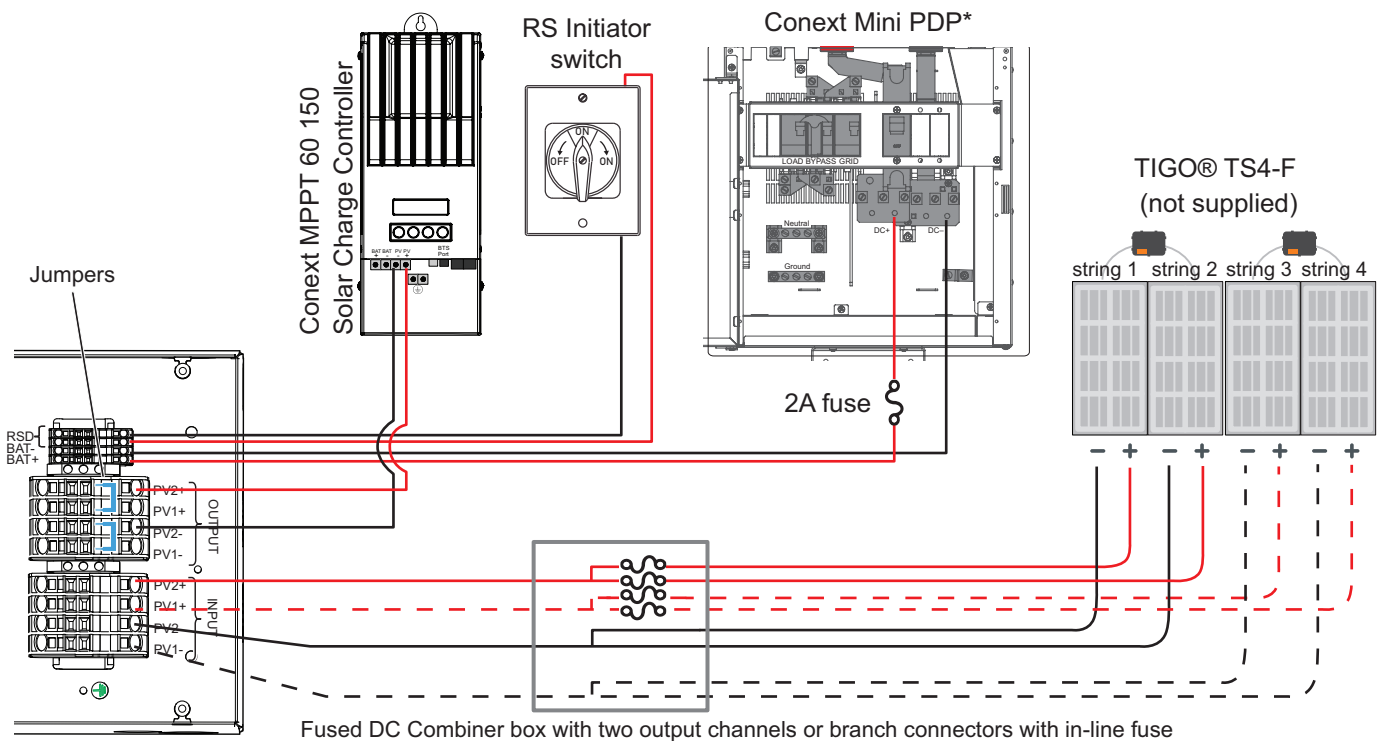

Figure 9 Connection to a single Conext MPPT 80 600 Solar Charge Controller



\*Connect the Bat+ and Bat- cables to the DC terminals in the Conext Power Distribution Panel (PDP), or the Conext Mini PDP. For details, see the *Conext Power Distribution Panel Installation Guide* (document number 975-0709-01-01) or the *Conext Mini Power Distribution Panel Installation Guide* (document number 975-0735-01-01).

Figure 10 Connection to a Conext MPPT 60 150 Solar Charge Controller



\*Connect the Bat+ and Bat- cables to the DC terminals in the Conext Power Distribution Panel (PDP), or the Conext Mini PDP. For details, see the *Conext Power Distribution Panel Installation Guide* (document number 975-0709-01-01) or the *Conext Mini Power Distribution Panel Installation Guide* (document number 975-0735-01-01).

**For Conext MPPT 60 150 only:** 32 A max. per input channel. Install the provided jumpers between output terminals PV1+ and PV2+, and PV1- and PV2- to combine output channels (see *Figure 10*).

### Wire Size and Over-Current Protection Requirements

The wiring, over-current protection devices (fuses and circuit breakers), and installation methods used must conform to all national and local electrical code requirements.

Wiring must be protected with conduits or strain relief clamps.

**⚠ WARNING**

**XANBUS SHOCK HAZARD**

- Do not route the Xanbus cables in the same conduit or panel as the AC and DC power cabling.
- Connect communications cables to their components after DC connections are made.
- RS Initiator switch cables and network cables must pass through a different conduit than the conduits used for PV, high current carrying conductors, and battery cables.
- Ensure that all metal conduits are properly grounded.

**Failure to follow these instructions can result in death, serious injury, or equipment damage.**

## Current Rating

The MPPT Disconnect RS PV input channels are rated for 32 A maximum  $I_{sc}$ . Since PV outputs can vary due to the array size or sunlight angle, the minimum wire size must be chosen for maximum array short-circuit current. Consult the PV array manufacturer specifications.

## Over-Current Protection

Over-current protection must be installed to protect the charge controller from short circuits and to provide a means of disconnecting the charge controller. Consult local electrical codes to establish the correct fuse or circuit breaker rating.

## Battery Cable Circuit

The NEC requires the battery circuit to be protected with a device rated for 125% of the rating of the circuit. The DC-rated fuse or circuit breaker between the battery and the MPPT Disconnect RS must be rated for  $1.25 \times 2$  A (the maximum current rating of the MPPT Disconnect RS).

## Long-Distance Wire Runs

If there is a significant distance between the PV array and the MPPT Disconnect RS, larger gauge wires can be used to help reduce the voltage drop and improve performance. Refer to the section below.

### **NOTICE**

#### **EQUIPMENT DAMAGE**

Wire sizes larger than #6 AWG (16 mm<sup>2</sup>) may be used to help reduce resistive losses, but should not be installed directly into the MPPT Disconnect RS. Use a splicer block or similar to connect wires of different gauges together. Follow the manufacturer's recommendations for torque and mounting.

**Failure to follow these instructions can result in equipment damage.**

## Maximum Distance and Wire Size

**Important:** Local and national electrical codes must be followed for determining additional installation requirements.

Refer to the table below for the maximum current, and the distance from the PV array to the MPPT Disconnect RS.

For equivalent metric wire sizes, consult a local electrician or certified installer.

Table 1 Wire distance and size

Charge controller	Imp	Size (AWG)	Length in ft	Resistance in kohm/ft	Voltage drop	Vmpp	% voltage drop
MPPT 60	23.3	10	50	1.24	2.88	104	2.77%
MPPT 60	23.3	6	100	0.49	2.28	104	2.20%
MPPT 60	23.3	6	150	0.49	3.42	104	3.29%
MPPT 80	11.6	14	50	2.53	2.94	350	0.83%
MPPT 80	11.6	14	100	2.53	5.87	350	1.68%
MPPT 80	11.6	12	150	1.59	5.54	350	1.58%
MPPT 80	23.3	14	50	2.53	5.87	350	1.68%
MPPT 80	23.3	12	100	1.59	7.38	350	2.11%
MPPT 80	23.3	10	150	1.24	8.65	350	2.47%

## Connecting the PV Input to MPPT Disconnect RS and charge controller

### **DANGER**

#### **HAZARD OF ELECTRIC SHOCK, EXPLOSION, ARC FLASH, AND FIRE**

The PV array will produce a hazardous voltage with even a small amount of light. Qualified personnel must follow safe electrical work practices when connecting the PV input to the MPPT Disconnect RS and charge controller.

**Failure to follow these instructions will result in death or serious injury.**

### **NOTICE**

#### **EQUIPMENT DAMAGE DUE TO OVER-VOLTAGE**

To help protect the MPPT Disconnect RS's insulation and conductors from damage due to a sudden over-voltage surge such as a lightning strike, install a DC-rated lightning arrester on the DC input line.

**Failure to follow these instructions can result in equipment damage.**

#### **To connect the PV input:**

1. If installed, ensure that the PV array disconnect switches are turned off. If there are no PV disconnect switches, incoming PV cables must be physically disconnected near the PV panels.

**NOTE:** Follow the installation manual for any compatible rapid shutdown receivers prior to connecting the PV input.

2. Connect a grounding conductor between MPPT Disconnect RS ground lug and the system ground. See specifications below.



Table 2 Ground cable specifications

Cable	Flange nut	Insulated terminal
Max. 6 AWG	M4	<ul style="list-style-type: none"> <li>▪ K.S.™ Insulated Ring Terminal RNYB14-4 or equivalent</li> <li>▪ Gauge: 6 AWG</li> <li>▪ Stud: M4</li> <li>▪ Length: 40 mm</li> <li>▪ Min. wire insulation entry width: 10 mm</li> </ul>

Figure 11 Ground/Earth conductor

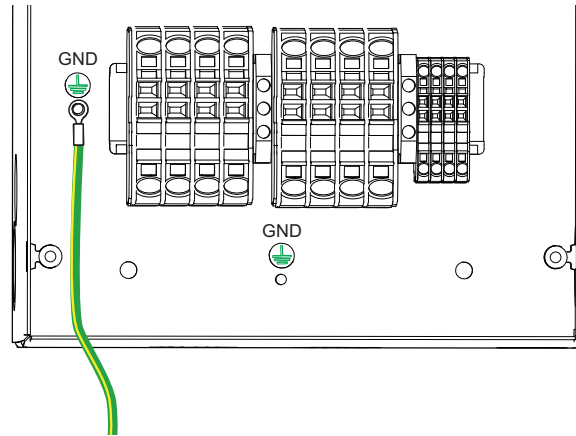

3. Using an appropriate wire stripping tool, remove approximately 20 mm of the insulation from the PV wires, as shown below.

Figure 12 PV wire preparation

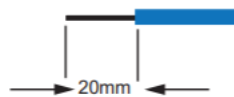

- Use a small flat head screwdriver to open the spring cage connection for the MPPT Disconnect RS's PV – input terminal (shown below), and then connect the PV array negative (–) to the PV – input terminal.

Figure 13 Spring cage connection

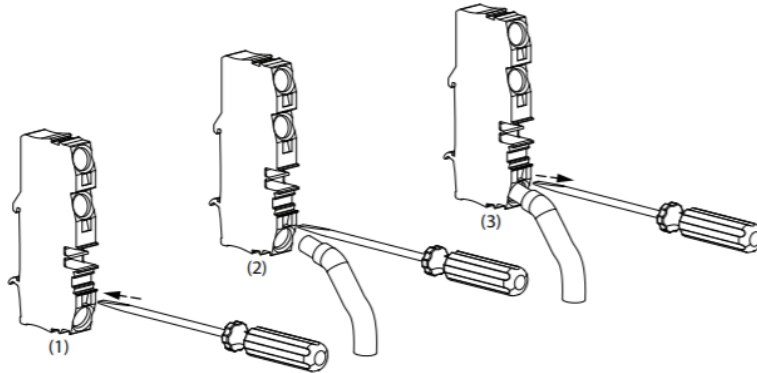
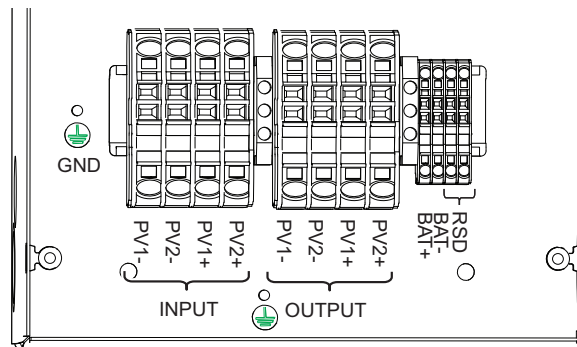

Figure 14 MPPT Disconnect RS connections



- Open the spring cage and connect the PV array positive (+) to the MPPT Disconnect RS input terminal marked PV+.
- Open the spring cage and connect the PV negative (–) output from the MPPT Disconnect RS to the charge controller terminal marked PV–.
- Open the spring cage and connect the PV positive (+) output from the MPPT Disconnect RS to the charge controller terminal marked PV+.

**To connect the battery input:**

- Before connecting battery cables, verify that the battery disconnect switches are turned off.
- Using an appropriate wire stripping tool, remove approximately 10 mm of the provided battery wire's insulation, as shown below.

Figure 15 Battery wire preparation

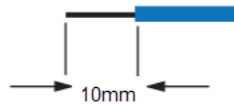

3. Use a small flat head screwdriver to open the spring cage connection for the MPPT Disconnect RS's BAT- terminal, and then connect the negative (-) battery cable from the DC- terminal in the Conext PDP or Conext Mini PDP to the BAT- terminal (see *Figure 8* to *Figure 10*).
4. Using the supplied 2 A fuse and cable assembly, connect the positive (+) battery cable from the MPPT Disconnect RS's BAT+ terminal to the DC+ terminal in the Conext PDP or Conext Mini PDP (see *Figure 8* to *Figure 10*).

## **NOTICE**

### **EQUIPMENT DAMAGE DUE TO REVERSE POLARITY**

Before making the final DC connection or closing the external DC breaker or the MPPT Disconnect RS's DC Disconnect switch, check cable polarity at both the battery and the charge controller.

**Failure to follow these instructions can result in equipment damage.**

#### **To connect the RS Initiator switch:**

1. Using an appropriate wire stripping tool, remove approximately 10 mm of the RS Initiator switch wire's insulation, as shown below.

Figure 16 RS Initiator switch wire preparation

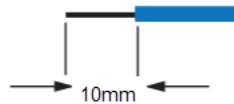

2. Use a small flat head screwdriver to open the spring cage connection for the MPPT Disconnect RS's "RS" terminals, and then connect the cable (sized for 0.25 A, max 14 AWG) from the "RS" terminals (shown in *Figure 17*) to the RS Initiator switch terminals (see the RS Initiator switch product manual for details):
  - a. Connect a wire from the RS terminal #3 to the RS Initiator switch's bottom right terminal.

Figure 17 RS Initiator switch connections

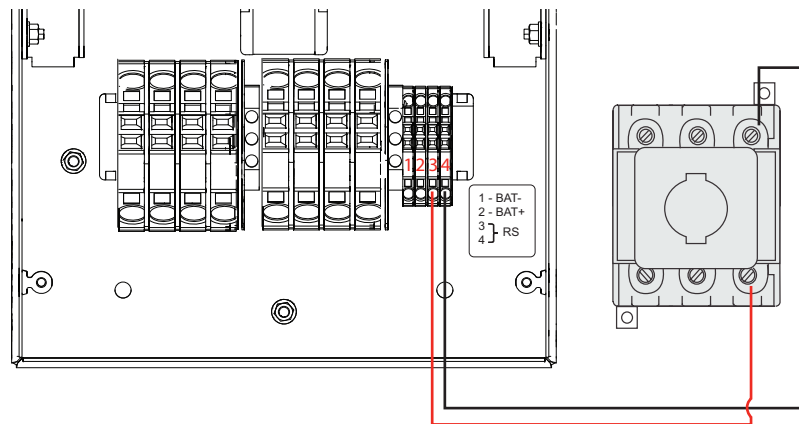

- b. Connect a wire from the RS terminal #4 to the RS Initiator switch's top right terminal.

## Network Installation

The MPPT Disconnect RS is a Xanbus-enabled device. Xanbus is a network communications protocol developed by Schneider Electric. The MPPT Disconnect RS is able to communicate its settings and activity to other Xanbus-enabled devices, such as a Conext inverter/charger, Conext Gateway, and Conext MPPT Solar Charge Controllers. Shutdown commands related to Arc Fault Detection or Rapid Shutdown are communicated over Xanbus.

Xanbus connections between multiple MPPT Disconnect RS' allow information about each unit and its associated equipment to be communicated in the system.

### **⚡ ⚠ WARNING**

#### **HAZARD OF ELECTRIC SHOCK AND FIRE**

Always install the Xanbus cable between the MPPT Disconnect RS and Conext MPPT charge controller. Without Xanbus connections, the disconnection of the system in the event of an arc fault will not be possible.

**Failure to follow these instructions can result in death, serious injury, or equipment damage.**

## Network Components

A Xanbus network consists of the following components:

- Xanbus-enabled devices:
  - Conext MPPT Solar Charge Controller
  - Conext XW inverter/charger
  - Conext Automatic Generator Start
  - Conext System Control Panel or Conext Gateway/ComBox

- Network cables—Each Xanbus-enabled device is connected by a standard Ethernet (CAT 5 or CAT 5e) cable, available from any computer supply store.

<b>NOTICE</b>
<p><b>EQUIPMENT DAMAGE</b></p> <p>Do not use crossover cables.</p> <p><b>Failure to follow these instructions can result in equipment damage.</b></p>

- Network terminators—the Xanbus network must be properly terminated at each end to help improve the communication signal quality on the network. Network terminators plug into network ports on Xanbus-enabled devices. The MPPT Disconnect RS and other Xanbus-enabled devices ship with one terminator. Depending on your network layout, this terminator may need to be inserted into another device elsewhere in the network.

*Figure 18 Network terminator*

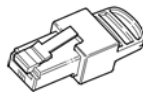

## Network Layout

Xanbus-enabled devices are connected with separate lengths of cable. The devices at each end of the chain must have a terminator inserted into their open network ports, as shown in the figure below.

**NOTE:** Install cable ties to attach the RJ45 cable to the cable tray, as shown below.

*Figure 19 Network*

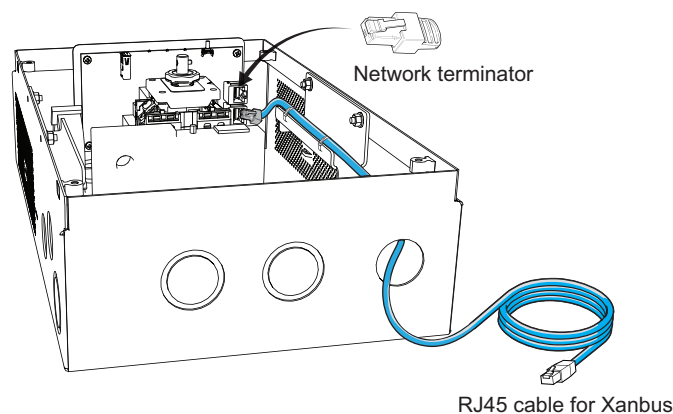

In a daisy chain layout, each device on the network is linked with separate lengths of cable, as shown in the figure below. The maximum number of Xanbus devices that can be connected is 15, with a baud rate of 256 kbps, and the maximum length is 40m.

Figure 20 Daisy chain layout

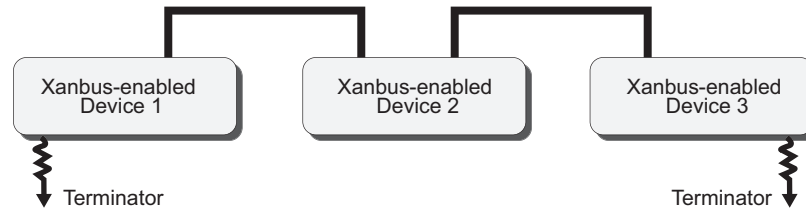

## Connecting Network Cables Between Multiple Units

### **⚠️ ⚠️ WARNING**

#### **ELECTRICAL SHOCK HAZARD**

- Do not route the network cables in the same conduit or panel as the DC input/ output cables.
- Before opening the MPPT Disconnect RS front cover, ensure the PV array and batteries are disconnected, following the instructions in *Lock-Out and Tag-Out (LOTO)* on page 6.

**Failure to follow these instructions can result in death, serious injury, or equipment damage.**

Single knockouts on the side and bottom of the MPPT Disconnect RS are provided for routing the Xanbus network cables.

### **NOTICE**

#### **EQUIPMENT DAMAGE**

- Connect only Xanbus-enabled devices. Although the cabling and connectors used in this network system are the same as ethernet connectors, this network is not an ethernet system.
- To avoid unpredictable device behavior, do not connect one end of the network to the other to make a ring or loop.

**Failure to follow these instructions can result in equipment damage.**

#### **To connect network cables between multiple units:**

1. Remove the top cover from each unit.
2. Remove a single knockout from the side or bottom of the MPPT Disconnect RSs.
3. Connect the network cable to a Xanbus port in MPPT Disconnect RS #1.
4. Route the cable to MPPT Disconnect RS #2.
5. Connect the network cable to a Xanbus port in MPPT Disconnect RS #2.
6. Connect another network cable to MPPT Disconnect RS #2 and route the cable to the next device in the network.
7. Ensure the factory-supplied network terminators are inserted into the empty Xanbus ports in the devices at the beginning and end of the network. There should be no empty Xanbus ports in any of the MPPT Disconnect RS.

## Reinstall the Front Cover and DC Disconnect Switch

1. Reinstall the four Phillips M4 x 25 mm screws on the front cover of the unit. Torque to 3.1 Nm (2.3 ft-lb).
2. Reinstall the plastic nut that goes under the DC Disconnect switch. Torque to 2-2.5 Nm (1.5-1.8 ft-lb).
3. Reinstall the switch knob using the small screw through the front of the DC Disconnect switch. Torque to 0.5-0.7 Nm (0.4-0.5 ft-lb).

*Figure 21 DC Disconnect switch and front cover reinstallation*

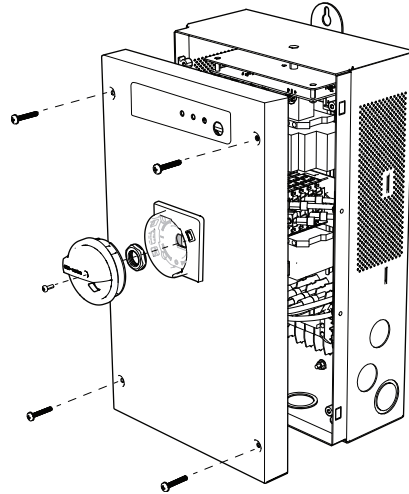

# 3 Commissioning

What's in This Chapter?

<b>Pre-Commissioning Inspections</b> .....	<b>27</b>
<b>Start-Up Procedure</b> .....	<b>27</b>



## Pre-Commissioning Inspections

Before applying power to the system, perform the following inspections:

- Clearances are correct.
- Wiring is complete and secure, per the instructions in the Installation and Owner's Guide:
  - DC/PV wiring
  - Earthing
  - Communication Interface with the Conext MPPT charge controller(s)
  - RS Initiator switch
- The RS Initiator switch is in the ON position
- The DC disconnect switch on the MPPT Disconnect RS is in the OFF position.
- Cable glands are installed on all used knockout holes.
- No tools or foreign materials inside the enclosure.
- Front cover is installed, and cover screws are torqued to 3.1 Nm (2.3 ft-lb).
- The PV modules are equipped with compatible models of Tigo® TS4-F, installed according to local codes and standards.
- The RS Initiator Switch label 885-91753 is fixed within 1 meter (3 ft) of the RS Initiator Switch assembly (refer to figure 690.56(C)(1)(a) in NEC 2017).

## Start-Up Procedure

1. Verify that the DC disconnect switch on the MPPT Disconnect RS is in the OFF position.
2. Verify that the battery fuse is in working condition and is installed properly.
3. Check the polarity of the DC and PV wires.
4. Ensure that the maximum DC voltage is not more than 60 V for the battery.
5. Turn ON the battery breaker (external) and wait for the MPPT Disconnect RS to operate normally, which is indicated by the flashing green **Status** LED. The **AFD** and **RS** LEDs should not be illuminated during normal operation.
6. If installed, turn ON the DC switch (external), or reconnect the PV cables at the PV panels.
7. Turn the MPPT Disconnect RS's DC Disconnect switch to the ON position.

If there is sufficient sunlight, the connected Conext MPPT charge controller(s) will start producing power.
8. Verify that the **AFD** LED is not red or flashing. Troubleshoot if necessary.
9. Check the status of the indicator lights on the display panel: The **Status** LED should be flashing green. If the status LED is not green, check that:

- a. All connections are correct.
- b. The RS Initiator switch is OFF.
- c. The battery fuse is in working condition and is installed properly.

For more information about the LEDs and troubleshooting, see *Troubleshooting on page 39*.



## 4 Operation

### What's in This Chapter?

<b>Front Panel UI</b> .....	<b>31</b>
<b>Arc Fault</b> .....	<b>31</b>
Arc Fault Detection .....	31
Resetting a Tripped AFD Device .....	32
<b>Rapid Shutdown</b> .....	<b>32</b>
Rapid Shutdown System Overview .....	33
Rapid Shutdown Self-Test .....	33
Clearing an RSD Fault .....	34
<b>DC Disconnect Switch</b> .....	<b>34</b>
<b>RS Initiator switch</b> .....	<b>35</b>
<b>MPPT Disconnect RS Control Power Supply</b> .....	<b>35</b>
<b>Communication</b> .....	<b>35</b>
Xanbus Connections .....	36

## Front Panel UI



The following table provides descriptions of the LEDs on the MPPT Disconnect RS's front panel.

Table 3 Front panel UI

Name	Description	LED status	Possible reason
Status	Green	Flashing green	Indicates normal operation
RS	Red	Solid red	Indicates that there is an RSD event present in the system
AFD	Red	Solid red	Indicates AFD Fault
		Blinking red	Indicates AFD self test failure
AFD Reset	Reset switch	N/A	This switch is provided to reset the AFD in the event of a false arc fault reading, or triggering an AFD self test

## Arc Fault

In a PV system, an electrical arc occurs when current bridges a gap between conductive surfaces. A series arc occurs across open connections in a single conductor. A parallel arc occurs if the current bridges multiple conductors that were meant to remain separate. The arc fault detection (AFD) in the MPPT Disconnect RS system is intended to help protect against series arcs.

  <b>WARNING</b>
<b>HAZARD OF ELECTRIC SHOCK AND FIRE</b>
Always install the Xanbus cable between the MPPT Disconnect RS and Conext MPPT charge controller. Without Xanbus connections, the disconnection of the system in the event of an arc fault will not be possible.
<b>Failure to follow these instructions can result in death, serious injury, or equipment damage.</b>

## Arc Fault Detection

The MPPT Disconnect RS includes an integrated arc fault detection (AFD) unit. The AFD unit requires the Control Power Supply to function. In the event of an arc fault in the PV system, the AFD helps to detect the arc, and sends a Xanbus signal to the charge controller, and then the charge controller opens the circuit and enters standby mode. The arc fault status is stored in the AFD memory, and will remain active until reset manually by an operator. The status of an arc event is indicated on the front panel of MPPT Disconnect RS by a solid red AFD LED. For instructions on clearing an Arc fault, see *Troubleshooting on page 39*.

The AFD self test occurs at startup and periodically (approximately every 24 hrs). At any time during operation, the user can initiate an AFD self test by pressing the **AFD**

**Reset** button for 10 seconds to check the health of the AFD device. If the test cannot complete successfully, the AFD indicator light will flash, as shown below.

Figure 22 AFD self test error

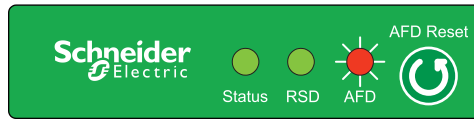

## Resetting a Tripped AFD Device

A tripped AFD device can be reset only manually. The MPPT Disconnect RS will display the arc fault via the AFD LED, as shown below.

Figure 23 AFD fault

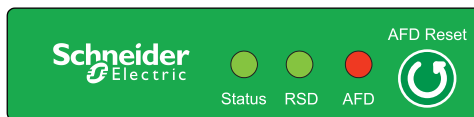

### To reset the AFD device:

1. Investigate the cause of the arc fault.
2. Before resetting the AFD device, power down the MPPT Disconnect RS and charge controller by turning off both battery and PV sources and applying LOTO.
3. Press the AFD reset button on the front panel of the MPPT Disconnect RS.
4. Once troubleshooting and the corrective action are complete, power up the MPPT Disconnect RS and charge controller.

## Rapid Shutdown

The rapid shutdown feature is intended for firefighters or first responders. In case of emergency, a responder may need to put the PV system into a de-energized state, (per NEC 690.12). The Rapid Shutdown Initiator switch is therefore required to be mounted at a readily accessible and visible location outside the building.

### **WARNING**

#### **HAZARD OF ELECTRIC SHOCK AND FIRE**

Always install the Xanbus cable between the MPPT Disconnect RS and Conext MPPT charge controller. Without Xanbus connections, the disconnection of the system in the event of an arc fault will not be possible.

**Failure to follow these instructions can result in death, serious injury, or equipment damage.**

## Rapid Shutdown System Overview

The first responder operates the RS Initiator switch by turning it to the OFF position. The MPPT Disconnect RS will then power off its internal RSD Transmitter, which will stop sending the signal through the PV conductors. This will result in opening all of the PV DC circuit conductors to reduce the PV voltage below 'safe' operating voltage (per NEC 690.12). The controlled conductors will reach this 'safe' operating voltage in under 30 seconds.

At the same time, the MPPT Disconnect RS sends signals to the connected charge controller to shut down. The MPPT Disconnect RS will display the RSD event via the RSD LED, as shown below.

Figure 24 RSD event

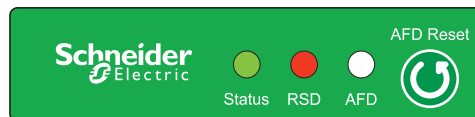

**NOTE:** The PV array rapid shutdown can be activated either by the remote RS Initiator switch or by the built-in DC disconnect switch on the front of the MPPT Disconnect RS.

**Important:** The Rapid Shutdown functionality is achieved only when the PV modules are equipped with compatible models of Tigo® TS4-F, installed according to local codes and standards. For more information, see *Specifications on page 43*.

After an RSD event, PV and battery connections to the MPPT Disconnect RS and charge controller(s) must be reset by qualified personnel.

## Rapid Shutdown Self-Test

The rapid shutdown should be tested every six months.

### To perform the test:

1. Turn the RS Initiator switch from the ON position to the OFF position.
2. Verify that the **RS** LED is illuminated red.
3. Measure the PV conductor voltage to verify that it is less than 30 V within 30 seconds.
4. After verification, turn the RS Initiator switch back to the ON position.
5. Follow the recovery steps by power resetting both PV and battery connections to the MPPT Disconnect RS and Conext MPPT charge controllers.
6. After power resetting, verify the normal operation of the MPPT Disconnect RS and the connected Conext MPPT charge controller(s).

## Clearing an RSD Fault

### To clear an RSD fault:

1. Ensure the RS Initiator switch is in the OFF position.
2. Turn off all sources of power to the Conext MPPT charge controllers, inverters, and MPPT Disconnect RS.
3. Wait for at least five minutes for the system to completely power off.
4. Turn the RS Initiator switch to the ON position.
5. Turn ON all sources of power to the Conext MPPT charge controllers, inverters, and MPPT Disconnect RS.
6. The inverters will be in standby mode. Enable them as necessary (using the inverter's front panel, Conext Gateway, or Conext System Control Panel (SCP)).

## DC Disconnect Switch

The MPPT Disconnect RS has a PV Disconnect switch that is used to turn off the PV array circuit. **NOTE:** Turning off the DC Disconnect switch will trigger the rapid shutdown of the PV array, but will not trigger the shutdown of the charge controller(s) or inverter.

The switch can be locked in the OFF position, and can be the lock-out point for servicing the charge controller(s). The DC Disconnect switch is a 4-pole switch, UL/CSA rated with 32 A, 600 VDC.

*Figure 25 DC Disconnect switch*

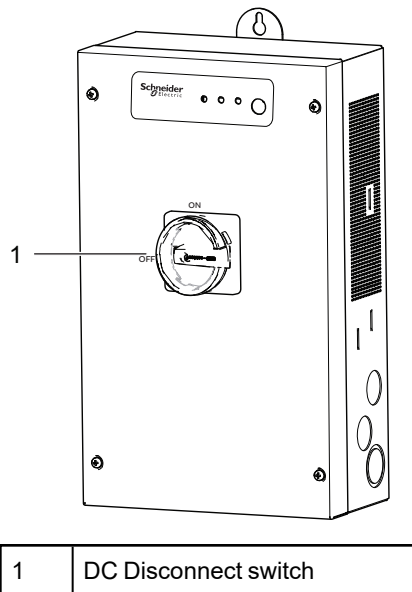



## RS Initiator switch

**Important:** The supplied RS Initiator switch must be connected in order for the rapid shutdown feature of the MPPT Disconnect RS to operate as intended. If it is not connected, there will be no power production.

Figure 26 RS Initiator switch

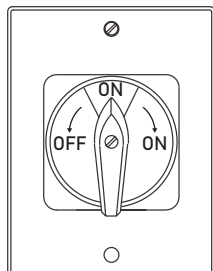

## MPPT Disconnect RS Control Power Supply

The battery terminal block inside the MPPT Disconnect RS supplies the control power. The control power supply input is supplied by batteries (22 VDC to 60 VDC max.) connected to the charge controller.

The Control Power Supply provides power to the RSD transmitter, AFD module, and RS Initiator switch.

## Communication

The MPPT Disconnect RS is a Xanbus-enabled device. Xanbus is a network communications system which allows the MPPT Disconnect RS to communicate settings and status information to other Xanbus-enabled devices. Xanbus connections between the MPPT Disconnect RS and multiple charge controllers allow information about each charge controller and its associated PV array to be communicated among all of the charge controllers in the system. Information about the entire system can be viewed on the Conext Gateway. Shutdown commands related to Arc Fault Detection or Rapid Shutdown are communicated over Xanbus.

**NOTE:** The Xanbus interface can be used for firmware upgrades.

For more information about the communication network, see *Network Installation on page 22*.

## Xanbus Connections

The pin definitions of the Xanbus (RJ-45) connections are shown in *Table 4*.

**NOTE:**

- External Xanbus surge protection devices are recommended to help avoid damages to Xanbus communication circuits when communication cables are exposed outside.
- Incorrect pin out for the RJ-45 cable or GND pins will result in discontinuity on the network and poor communication.
- It is recommended to use a shielded Cat5 cable 24 AWG.

*Table 4 RJ-45 pin details*

Pin	Conductor name	CAT 5 cable insulation color
1	NET_S	White/Green
2	NET_S	Green
3	NET_C	White/Orange
4	CAN_L	Blue
5	CAN_H	White/Blue
6	NET_C	Orange
7	NET_S	White/Brown
8	NET_C	Brown



# 5 Troubleshooting

What's in This Chapter?

**Troubleshooting** ..... **39**

# Troubleshooting

DANGER

**HAZARD OF ELECTRIC SHOCK, EXPLOSION, ARC FLASH, AND FIRE**

This chapter includes tasks that must be performed only by qualified personnel equipped with appropriate personal protective equipment and following safe electrical work practices. Review the *Safety Information on page 6* before proceeding.

**Failure to follow these instructions will result in death or serious injury.**

To determine the cause of an MPPT Disconnect RS error condition, refer to the troubleshooting table below for possible solutions. If you are unable to resolve the issue after referring to this table, contact your supplier or Schneider Electric Customer Service.

Table 5 Troubleshooting

Indication	Cause	Solution
AFD LED is blinking RED	AFD self test failure	<ol style="list-style-type: none"> <li>1. Verify that the AFD terminals are connected properly.</li> <li>2. Verify that power supply voltages are within the specified range.</li> <li>3. Inspect/test the AFD module to verify normal operation.</li> </ol>
AFD LED is solid RED	AFD event	<ol style="list-style-type: none"> <li>1. Verify that there is no physical damage to the PV Input/Output wiring from the MPPT Disconnect RS.</li> <li>2. Verify that connections are correct and secure at the MPPT Disconnect RS Input/Output terminals and PV Disconnect switch. Also verify that terminals at the charge controller are connected properly.</li> <li>3. Investigate the cause of the arc fault event, and then power up the units once troubleshooting is complete (see <i>Resetting a Tripped AFD Device on page 32</i>).</li> <li>4. In the case of a false arc fault event, reset the AFD using the Reset switch, and then verify that the <b>AFD</b> LED is off.</li> </ol>
RS LED is solid RED	RSD event	<ol style="list-style-type: none"> <li>1. Verify that the external RS Initiator switch is not in the OFF position. For normal operation of the MPPT Disconnect RS and Conext MPPT charge controller, the RS Initiator switch must be in the ON position.</li> <li>2. Verify that the RS Initiator switch is wired properly at the MPPT Disconnect RS terminals.</li> <li>3. Verify the power supply operation.</li> </ol>
PV not available at charge controller	--	<ol style="list-style-type: none"> <li>1. Verify that the <b>Status</b> LED is flashing green and the <b>RSD</b> LED is not illuminated.</li> <li>2. Verify that the DC Disconnect switch on the MPPT Disconnect RS is in the ON position.</li> <li>3. Verify that the Input/Output cables are connected properly.</li> </ol>

All LED's are OFF	No control power supply	Check the control side wiring.
	Battery is disconnected	<ol style="list-style-type: none"> <li>1. Verify that the battery breaker to the MPPT Disconnect RS is off. Then Turn it on.</li> <li>2. Verify that the battery voltage is 22 VDC min. and check the health of the battery.</li> <li>3. Verify that the 2 A fuse connected between the Conext PDP's DC+ terminal and the MPPT Disconnect RS is in working condition.</li> </ol>
<b>Status</b> LED is flashing GREEN, but no PV power to charge controller	MPPT Disconnect RS Disconnect switch is OFF	<ul style="list-style-type: none"> <li>▪ Turn on the DC disconnect switch.</li> <li>▪ Verify that the Tigo device is one of the models listed in <i>Rapid Shutdown System Overview on page 33</i>, and that it is in working condition.</li> </ul>
<b>Status</b> LED is flashing GREEN, but Conext MPPT charge controller has reduced PV input power	Array wiring error or poor connection.	Check all PV wiring to the PV combiner. Use a calibrated multimeter to confirm the voltage of each subarray at the combiner input terminals.
<b>RS</b> LED is RED	RS Initiator switch is in the OFF position.	<ol style="list-style-type: none"> <li>1. Verify that the position of the RS Initiator switch is ON. If position is ON, then check the switch wiring to the MPPT Disconnect RS.</li> <li>2. Perform a power reset to the MPPT Disconnect RS and connected Conext MPPT charge controller(s) by resetting the PV and battery breakers.</li> </ol>
MPPT Disconnect RS not detecting RS Initiator switch operation	PV does not disconnect during RS Initiator switch operation	<ol style="list-style-type: none"> <li>1. Verify that the RS Initiator switch is working. If it is working as expected, then check the switch wiring to the MPPT Disconnect RS.</li> <li>2. Verify that a rapid shutdown signal detector is installed at the PV array (see <i>Rapid Shutdown System Overview on page 33</i> for compatible models).</li> <li>3. Verify that rapid shutdown signal detector is functioning:             <ol style="list-style-type: none"> <li>a. Turn the DC Disconnect switch on the MPPT Disconnect RS to the OFF position.</li> <li>b. Measure the PV conductor voltage to verify that it is less than 30 V within 30 seconds.</li> </ol> </li> </ol>



## 6 Specifications

What's in This Chapter?

<b>Specifications</b> .....	<b>43</b>
Torque Values .....	<b>44</b>



# Specifications

Table 6 MPPT Disconnect RS Specifications

<b>Electrical specifications</b>	
Max. PV array open circuit voltage	600 VDC
Max. PV current (Isc)	32 A (25.6 A @ STC) x 2 channels
Control power nominal voltage	48 VDC
Control power input range (battery)	22 VDC to 60 VDC
Max. Control Power input current	2 A
Max. and min. wire size in conduit at input	#6 AWG to #14 AWG (8 to 2.5 mm <sup>2</sup> )
Max. and min. wire size in conduit at output	#6 AWG to #14 AWG (13.5 to 2.5 mm <sup>2</sup> )
Conductor type	Certified for use with 75°C copper conductors
PV Input and Output connection	Push In cage clamp, CU type cable compatible
Battery connection	Push In cage clamp, CU type cable compatible
RS Initiator switch connection	Push In cage clamp, CU type cable compatible
<b>General specifications</b>	
Part number	865-1036
Material	Sheet metal chassis and cover, with 34.54 mm and 27.78 mm (1.36 in and 1.09 in) knockouts. Unit status LED indicators and DC Disconnect switch.
PV Arc fault circuit protection	Type 1
Enclosure type	Type 1, indoor rated
Product weight	4.5 kg (10 lb)
Shipping weight	6 kg (13 lb)
Product dimensions (H x W x D)	36.8 x 22 x 14.5 cm (14.48 x 8.66 x 5.7 in)
Shipping dimensions (H x W x D)	28.5 x 44.0 x 29.0 cm (11.22 x 17.32 x 11.41 in)
Device mounting	Vertical wall mount
Ambient air temperature for operation	-20°C to 50°C (-4°F to 122°F)

Storage temperature range	-40°C to 85°C (-40°F to 185°F)
Relative humidity	Less than 85%, non-condensing
Operating altitude	Sea level to 6562 ft (2000 m)
System network and remote monitoring	Xanbus
PV disconnection	DC Disconnect Switch, 2 channel
Type of Rapid Shut Down	Photovoltaic (PV) rapid shutdown system (PVRSS)
Rapid shutdown time limit	30 seconds
Warranty	Five-year standard
User interface	3 LEDs, 1 user switch, RSD Initiator switch, and Xanbus
<b>Regulatory</b>	
Safety	CSA certified to UL1741, UL1741 CRD - PV Rapid Shutdown, UL1699B, CSA C22.2 No. 107.1-16, CSA C22.2 No.292-18, CSA (LTR) No. AE-004-2015
EMC	FCC and Industry Canada (Class B)
<b>Rapid Shutdown Initiator Switch (ordered separately)</b>	
Part number	865-1039
Enclosure type	NEMA 4x
Ambient air temperature for operation	-20°C to 50°C (-4°F to 122°F)
<b>Compatible products</b>	
Conext MPPT charge controller	Conext MPPT 80 600, Conext MPPT 60 150
Rapid Shutdown Receivers	<ul style="list-style-type: none"> <li>▪ TS4-F</li> <li>▪ TS4-R-F</li> <li>▪ TS4-A-F</li> <li>▪ TS4-A-2F</li> </ul>

## Torque Values

Table 7 Fastener torque values

Fastener type	Torque Nm (ft-lb)
Front cover screws	2.6 (1.9)
DC switch knob fastener	0.5-0.7 (0.4-0.5)
Plastic nut for DC switch	2-2.5 (1.5-1.8)
Wall mounting screws	3.1 (2.3)
Ground/Earth nut	2.7 (1.99)



## **Schneider Electric**

As standards, specifications, and designs change from time to time, please ask for confirmation of the information given in this publication.

For other country details please contact your local Schneider Electric Sales Representative or visit the Schneider Electric Solar Business website at: <http://solar.se.com/>

© 2023 Schneider Electric. All Rights Reserved.