



# QuickMount® Lynx® Metal Roof Attachment

## Connect with Confidence

QuickMount® has always been known for high-quality solar attachments and Lynx® now expands that portfolio into standing seam metal roofs. This roof type can be a great option for many buildings—durable, low-maintenance, and water-tight—with seams to securely attach equipment.

Lynx® is a robust, non-penetrating clamp for attaching solar. Designed for use with the IronRidge® L-Foot and IronRidge® Rails, it offers a complete system on many standing seam roof profiles. Lynx® can also support other racking platforms, with additional engineering.

Lynx® is part of a UL 2703 listed system and is integrated with our Pitched Roof Design Assistant software, so you can connect your next system with the utmost confidence. The technology in this product is licensed by S-5!®.

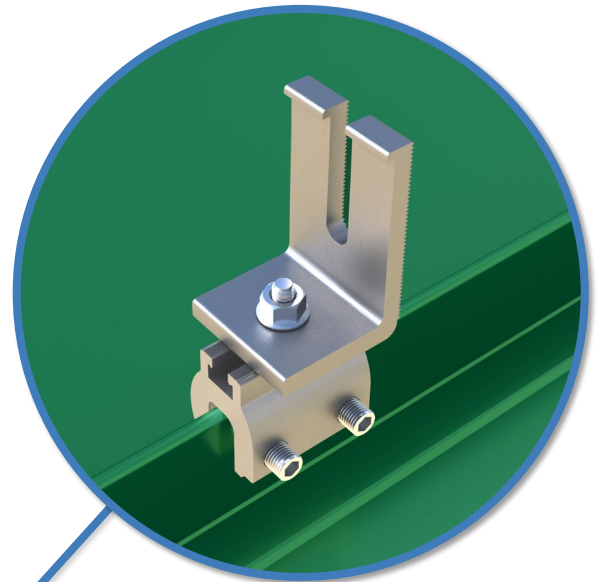

### N-S Adjustability for IronRidge® L-Feet

Lynx® features an open-ended T-slot for north-south adjustability, to easily line up rails. That means 2" of available adjustment for sliding L-Feet to properly connect them to rails. Coming fully packaged with the attachment hardware, Lynx® is designed for use with IronRidge® open-slotted L-Feet and IronRidge Rails.

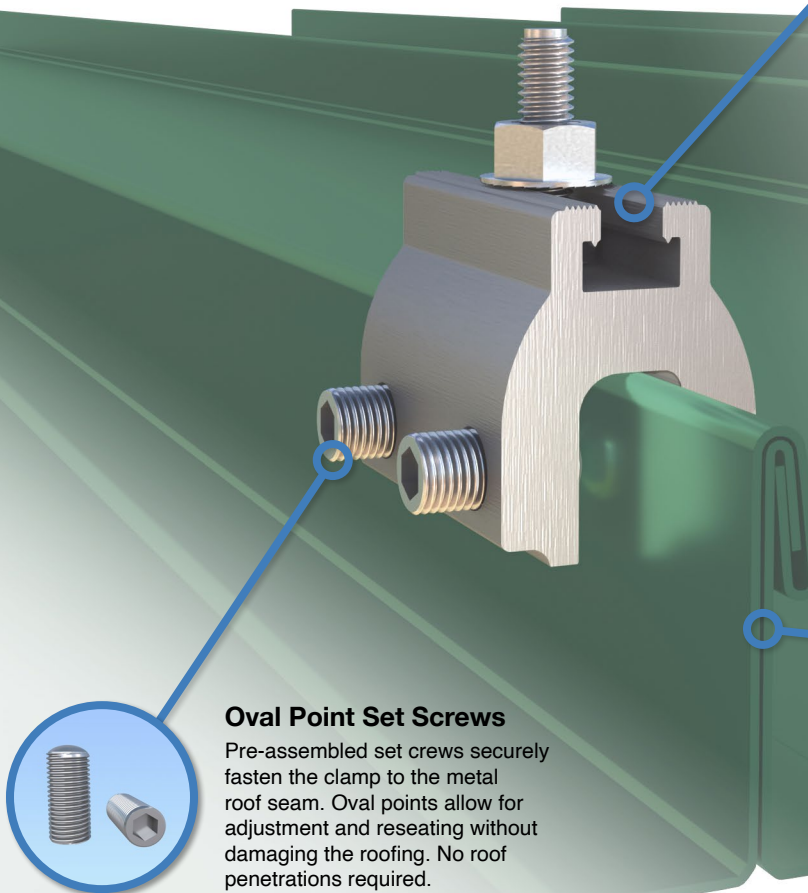

### Oval Point Set Screws

Pre-assembled set crews securely fasten the clamp to the metal roof seam. Oval points allow for adjustment and reseating without damaging the roofing. No roof penetrations required.

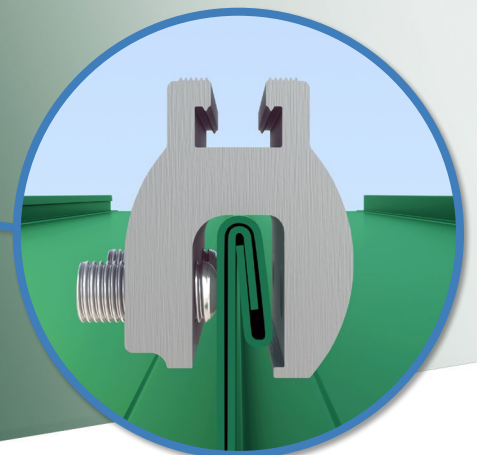

### Vast Standing Seam Compatibility

Lynx® can be used on a majority of standing seam profiles used for metal roofs, including many snapping and folding standing seams. See backside for a comprehensive guide on the specific standing profiles that fit best.



**25-Year Warranty**  
Product guaranteed free of impairing defects.



## Lynx® Metal Roof Compatibility

QuickMount® Lynx® can be used on standing seam roofs (folding and snapping styles) with a vertical seam height of at least 1.0" and a horizontal seam width maximum of 0.5". See the Flush Mount Installation Manual for installation details.

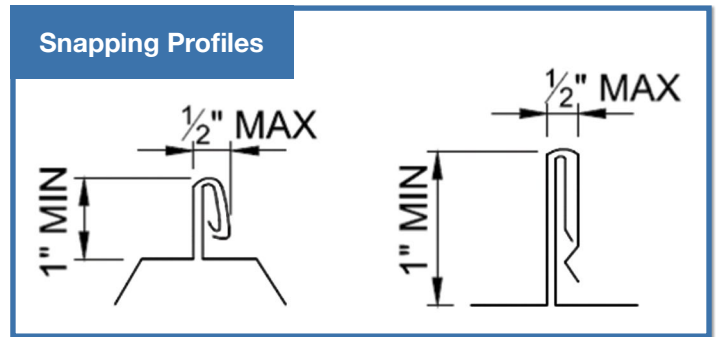
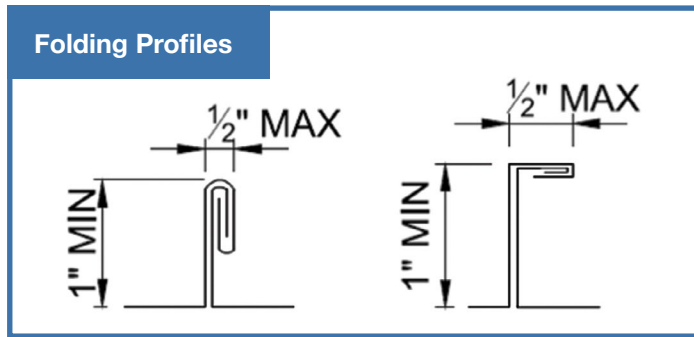

## Lynx® Racking Compatibility

Lynx® is part of the QuickMount® family of quality solar attachments, engineered and certified to perform with IronRidge® XR Rails®—but also performs well under other racking solutions. Consider it on your next metal roof project.

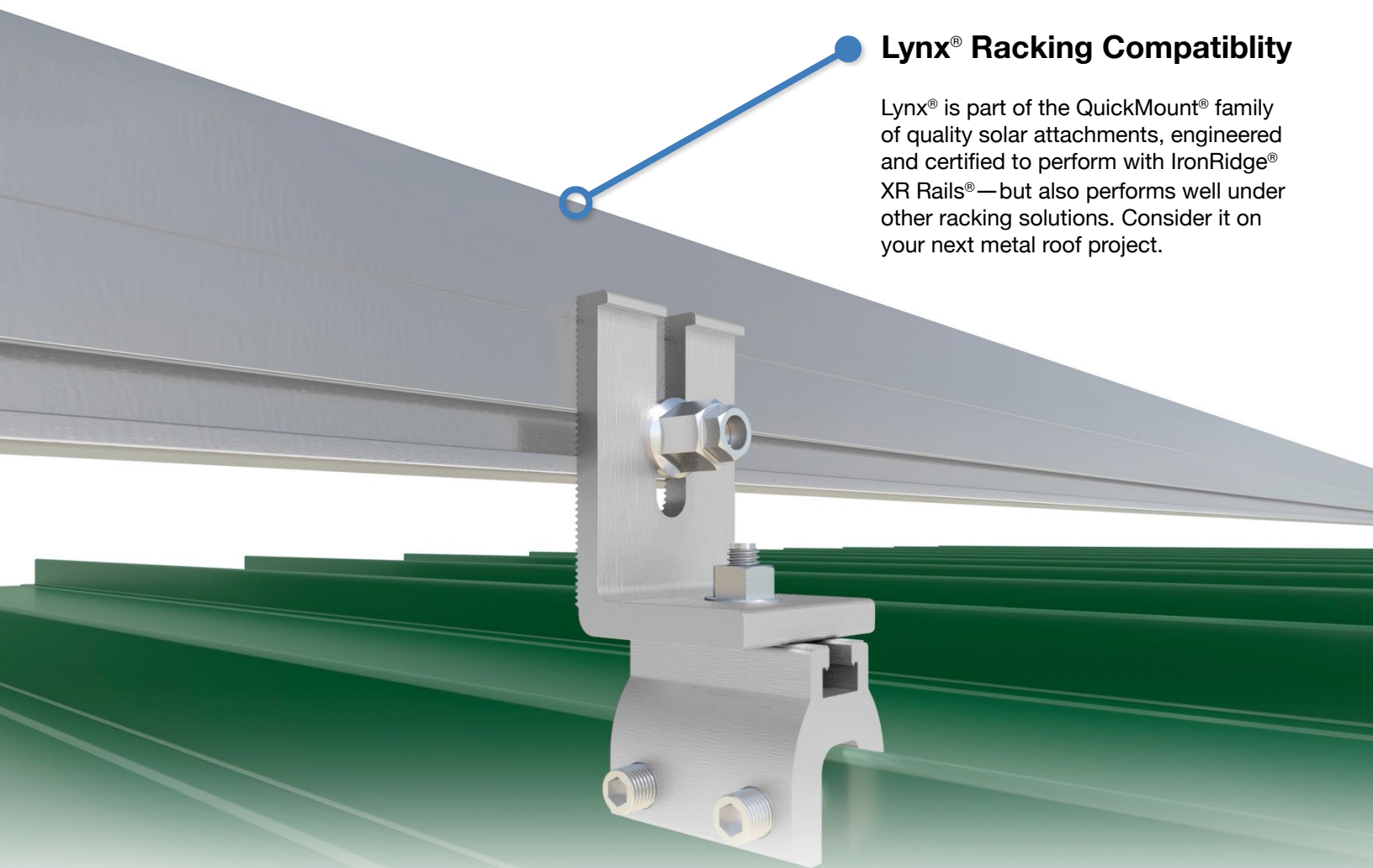

### Included in Design Assistant

Lynx® is available in our Pitched Roof Design Assistant, along with a stamped certification letter.



### Certification & Testing

Lynx® is a certified component that has been tested and evaluated to conform with UL 2703.

